

Facts Devices Tcsc, Statcom and Upfc Based Power System Stability Enhancement under Three Phase Faultwith Acive Filters

- #¹Dr.A.MALLIKARJUNA PRASAD, Associate Professor, Vardhaman College Of Engineering, Shamshabad, mallikarjunaprasad0307@gmail.com
- #²UTUKURU CHAITHANYA ,Assistant Professor,G.Pullaiiah College Of Engineering, Kurnool, chaithanya2099@gmail.com
- #³Dr,THIRU M.VELUSWAMY, Visiting Professor, Annamalai University, Annamalai Nagar, Chidambaram

ABSTRACT- With the ever increasing complexities in power systems across the globe and the growing need to provide stable, secure, controlled, economic and high quality power especially in the deregulated power market. It is envisaged that FACTS controllers will play a vital role in power systems. This paper investigates the improvement of transient stability of a test system under three phase fault using facts devise. TCSCThyristor Controlled Series Capacitor and STATCOM- Static Synchronous Compensator are utilized as a series and shunt compensation respectively. UPFC-Unified Power Flow Controller is considered as a shunt-series compensator.

Index Terms- TCSC; STATCOM; UPFC; Transient stability.

I. INTRODUCTION

Today's power system is a complex network comprising of generator, transmission lines, variety of loads and transformers. With the ever increase in power demand some transmission line is more loaded than was planned when they were built [1]. With increased loading of long transmission line the problem of transient stability after major disturbance, will cause the entire system to subside. Power system stability is the ability of electric power system, for a given initial operating condition to regain a state of operating equilibrium after being subjected to a physical disturbance, with most system variables bounded so that practically the entire system remains intact [2]. And the main challenges of modern power system is transient stability is referred as the capability of the system to maintain synchronous operation in the event of large disturbance and this kind of stability depends on parameters of system and intensity of disturbance [3] [4].

The recent development of power electronics introduces the use of flexible ac transmission system (FACTS) controllers in power system [5]. FACTS technology provides the opportunity to [6] [7]–

- Increase loading capacity of transmission lines. Prevent blackouts.

- Improve generation productivity.
- Reduce circulating reactive power.
- Improves system stability limit.
- Reduce voltage flicker.
- Reduce system damping and oscillations.
- Control power flow so that it flows through the designated routes. Congestion management

The conventional control devices like synchronous condenser, saturated reactor, thyristor controlled reactor, fixed capacitor thyristor controlled reactor, thyristor switched capacitor having less system stability limit, less enhancement of system damping, less voltage flicker control when compared to emerging facts devices like TCSC, STATCOM and UPFC [8][9]. This paper investigates the improvement of system stability with various emerging FACTS devices and their comparisons. [10] - [13]

II. DESCRIPTION OF FACTS DEVICES

A. TCSC

The basic conceptual TCSC module comprises a series capacitor, C, in parallel with a thyristor-controlled reactor, LS, as shown in Fig.1. A TCSC is a series-controlled capacitive reactance that can provide continuous control of power on the ac line over a wide range. The principle of variable-series compensation is simply to increase the fundamental-frequency voltage across an fixed capacitor in a series compensated line through appropriate variation of the firing angle. This enhanced voltage changes the effective value of the series-capacitive reactance and control the reactive power [9] [14].

B. STATCOM

STATCOM is a controlled reactive-power source. It provides the desired reactive-power generation and absorption entirely by means of electronic processing of the voltage and current waveforms in a voltage-source converter (VSC). A single-line STATCOM power circuit is shown in Fig.2

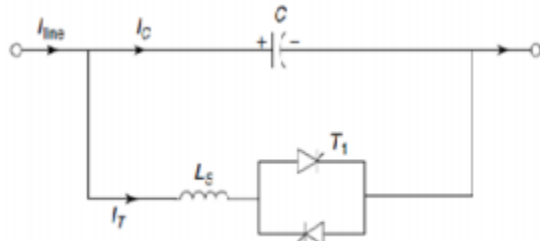

Figure1-Configuration of TCSC

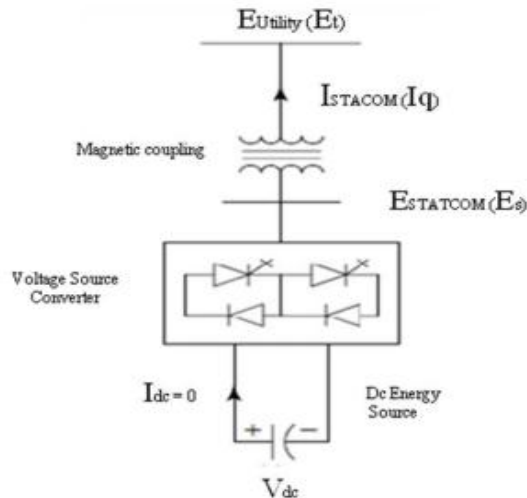

Figure 2-Configuration of STATCOM

where a VSC is connected to a utility bus through magnetic coupling. The exchange of reactive power between the converter and the ac system can be controlled by varying the amplitude of the 3-phase output voltage, E_s , of the converter. That is, if the amplitude of the output voltage is increased above that of the utility bus voltage, E_t , then a current flows through the reactance from the converter to the ac system and the converter generates capacitive-reactive power for the ac system. If the amplitude of the output voltage is decreased below the utility bus voltage, then the current flows from the ac system to the converter and the converter absorbs inductive-reactive power from the ac system. If the output voltage equals the ac system voltage, the reactive-power exchange becomes zero, in which case the STATCOM is said to be in a floating state [9] [15] – [16].

C. UPFC

The UPFC is the most versatile FACTS controller developed so far, with all encompassing capabilities of voltage regulation, series compensation, and phase shifting. It can independently and very rapidly control both real- and reactive power flows in a transmission line. It is configured as shown in Fig.3 and comprises two VSCs coupled through a common dc terminal.

One VSC-converter 1 is connected in shunt with the line through a coupling transformer, the other VSC-converter 2 is inserted in series with the transmission line through an interface transformer. The dc voltage for both converters is provided by a common capacitor bank. The series converter is controlled to inject a voltage phasor, V_{pq} , in series with the line, which can be varied from 0 to

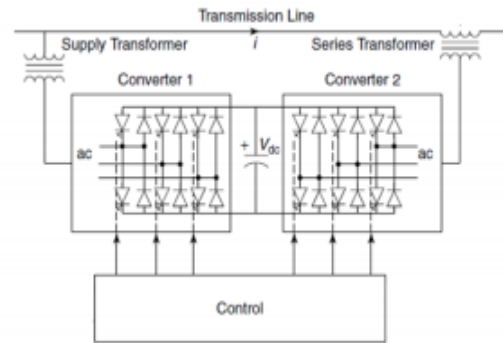

Figure3-Configuration of UPFC

V_{pq} max. Moreover, the phase angle of V_{pq} can be independently varied from 0 to 360 degree. In this process, the series converter exchanges both real and reactive power with the transmission line. Although the reactive power is internally generated/absorbed by the series converter, the real-power generation/absorption is made feasible by the dc-energy storage device that is, the capacitor. The shunt-connected converter 1 is used mainly to supply the real-power demand of converter 2, which derives from the transmission line itself. The shunt converter maintains constant voltage of the dc bus. Thus the net real power drawn from the ac system is equal to the losses of the two converters and their coupling transformers. In addition, the shunt converter behaves like a STATCOM and independently regulates the terminal voltage of the interconnected bus by generating/absorbing a requisite amount of reactive power [9] [17] – [18]

III. MODEL OF TEST SYSTEM

The below test network is tested with TCSC, STATCOM, and UPFC separately to investigate the behavior with five parameters such as generator voltage (V_g), generator current (I_g), generated load angle (δ), voltage near infinite bus (V_b) and current near infinite bus (I_b). These are done through MATLAB/SIMULINK with following stages

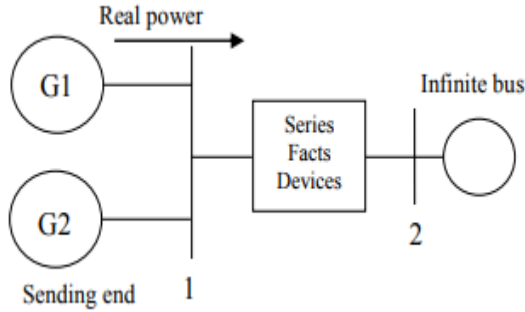

Figure 4. Test system with series FACTS device

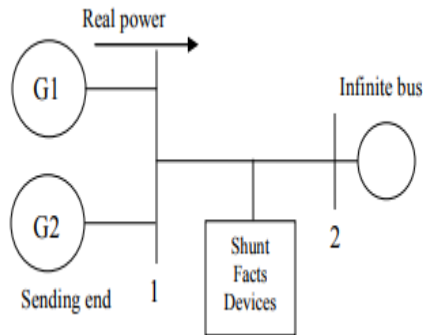

Figure 5. Test system with shunt FACTS device

Stage 1 -To design test system shown in fig 6

Stage 2 - To measure five parameters under normal operating condition.

Stage 3 -To create three phase fault near to infinite bus in test system. Fault duration 0.5 to 0.6 seconds. Shown in fig 7.

Stage 4- To measure five parameters under three phase fault conditions

Stage 5 - To design FACTS devices (TCSC, STATCOM and UPFC) Shown in fig 8, fig 9 and fig 10 respectively.

Stage 6- To connect FACTS devices (0.6 to 0.8 seconds) in test system under three phase fault condition and to measure behavioral change of system.

The test system specification is

- Generator 1, 2 - 10KV, 110MW, 300 rpm,
- TCSC - 10MVAR, 10KV,
- STATCOM - 10MVAR, 10KV and
- UPFC - 10MVAR, 10KV.

IV. RESULT AND DISCUSSION

In accordance with the above SIMULINK work the five different parameters - generator voltage (V_g), generator current (I_g), generated load angle (δ), voltage near infinite bus (V_b) and current near infinite bus (I_b) of test system is measured and the settling time of each parameter is calculated for system stability and also to maximize the power flow in transmission line.

The simulation result for generator voltage (V_g) of phase A is shown in fig 11. It is clear that under three phase fault, without FACTS device the voltage fluctuation of generator is more, whereas, it is less when the FACTS devices are involved. A table for generator voltage (V_g) under different time interval is constructed from the observed result. During the time interval of 0.5 to 0.8 seconds and 0.8 to 3.2 seconds the voltage rises from 3200 to 5000 volts and from 5000 to 8000 volts respectively which is greater than the generator voltage (V_g) without the involvement of FACTS device. So, when FACTS devices are connected to the system, it takes 2.4 seconds for TCSC, 2.0 seconds for STATCOM and 1.4 seconds for UPFC to reach the stability level.

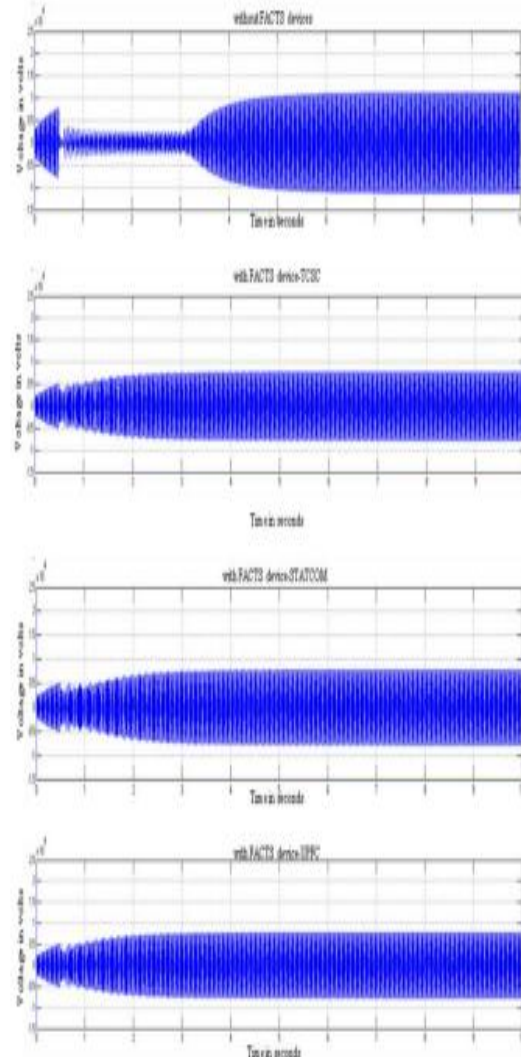

Figure 11. Simulation Result for Generator Voltage (V_g)

Table 1. Generator Voltage (V_g) in volts

Generator Voltage (Vg) in volts	Time in seconds	0 to 0.5	0.5 to 0.6	0.6 to 0.8	0.8 to 3.2	3.2 to 10
	Without FACTS device		0 to 5000	2000 to 0	4000	4000
TCSC		0 to 5000	3200	3200 to 5000	5000 to 8000	8000
STATCOM		0 to 5000	3200	3200 to 5000	5000 to 7000	7000 to 8000
UPFC		0 to 5000	3200	3200 to 5000	5000 to 7600	7600 to 8000

The fig 12 shows the generator current (I_g) of phase A. The generator current (I_g) is reached to stable at 4.4 seconds when the FACTS devices are not connected. After incorporating the FACTS devices TCSC, STATCOM and UPFC, the settling time of generator current (I_g) is reduced as 2.4, 3.4 and 2.3 seconds respectively for reaching the stable condition, Which is understood through table 2.

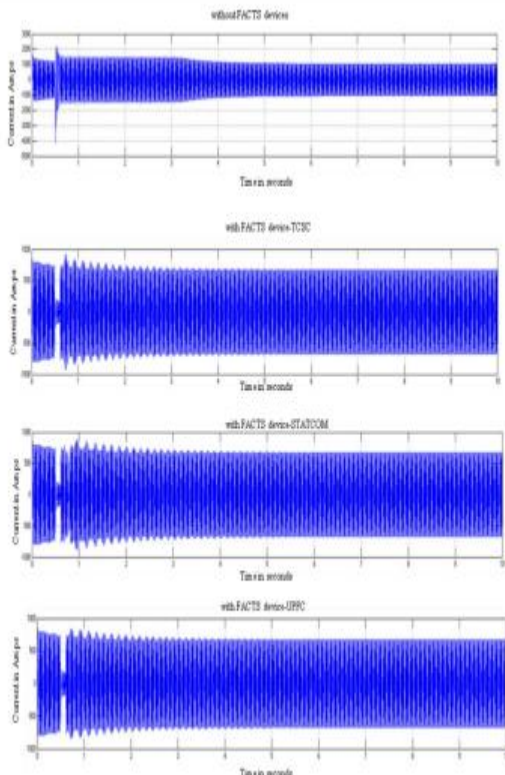

Figure 12. Simulation Result for Generator Current (I_g)

Table 2. Generator Current (I_g) in Amps

Generator Current (I _g) in Amperes	Time in seconds	0 to 0.5	0.5 to 0.6	0.6 to 0.8	0.8 to 3.2	3.2 to 10
	Without FACTS device		1500 to 1250	5000	1500	1500
TCSC		800 to 750	200	1000	1000 to 700	700
STATCOM		800 to 750	200	800	800 to 700	700
UPFC		800 to 750	200	800	800 to 700	700

Before connecting the FACTS devices in test system the load angle (δ) of generator is varied up to 18 degree and takes around 7.4 seconds to settle down to stable region after the fault recovery. But due to the interfacing of FACTS device the settling time is reduced to 4.2, 4.4 and 4.2 seconds for TCSC, STATCOM and UPFC respectively is shown in fig 13 and table 3.

Generator Load degree	Time in seconds	0 to 0.5	0.5 to 0.6	0.6 to 0.8	0.8 to 3.2	3.2 to 10
	Without FACTS device		1.5	3.5	18	18
TCSC		2.5	4	4 to 2	2 to 0.2	0.2 to 0
STATCOM		2.5	4	4 to 3	3 to 0.4	0.4 to 0
UPFC		2.5	4	4 to 2.5	2.5 to 0.1	0.1 to 0

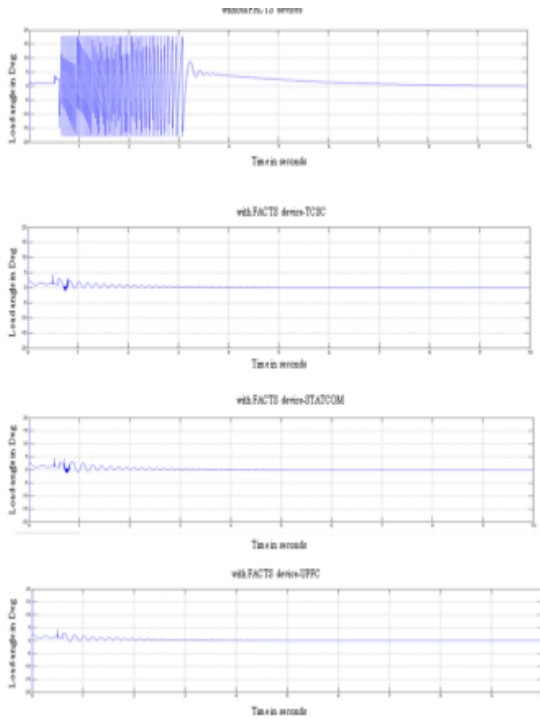

Figure 13. Simulation Result for Generator Load Angle (δ)

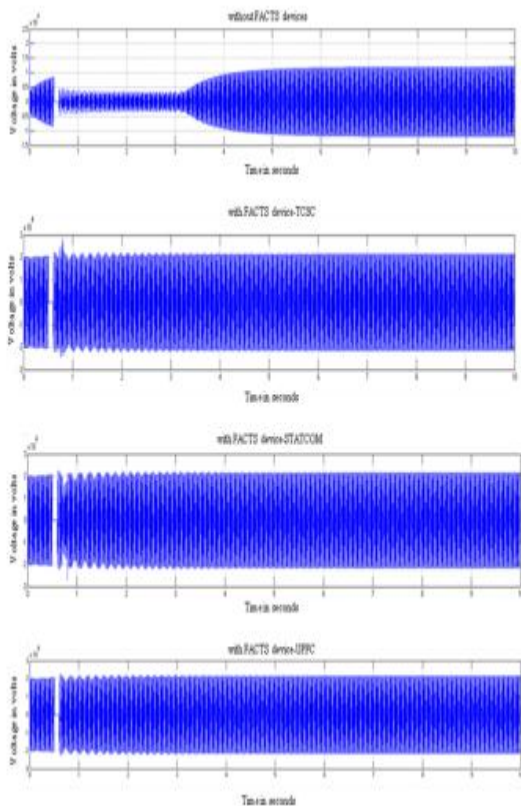

Figure 14. Simulation Result for Voltage near Infinite Bus (V_b)

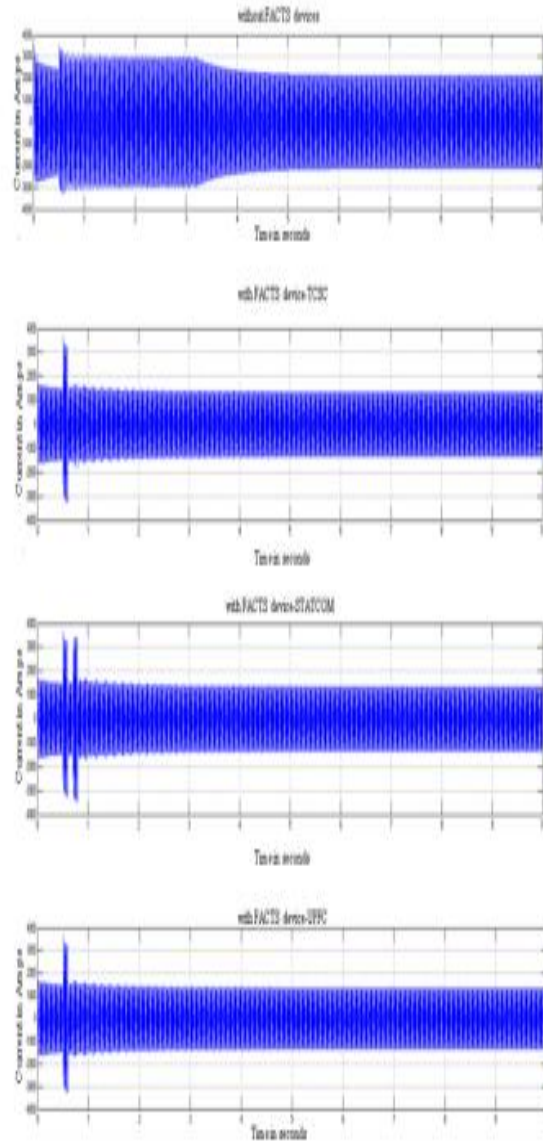

Figure 15. Simulation Result for Current near Infinite Bus (I_b)

From Fig 14 it is observed that the settling time for the voltage near infinite bus (V_b) is 5.4 seconds when the FACTS devices are not connected. After connecting the FACTS devices settling time is reduced as 0.4, 0.5 and 0.2 seconds for stable condition. Similarly the current near infinite bus (I_b) comes to stable within 0.4, 0.5 and 0.2 seconds for TCSC, STATCOM and UPFC respectively after the fault recovery. But without those devices it takes 3.4 seconds to reach stability is shown in fig 15. The settling time of V_g , I_g , δ , V_b , I_b for TCSC, STACOM and UPFC are studied and shown in table 4. It is found that the system stability is achieved in short interval while interfacing UPFC.

TABLE 5. COMPARISON OF SETTLING TIME

Settling time in seconds				
Parameters	Without FACTS devices	TCSC	STATCOM	UPFC
Generator voltage (V_g)	4.4	2.4	2	1.4
Generator Current (I_g)	4.4	2.4	3.4	2.3
Generator load angle (δ)	7.4	4.2	4.4	4.2
Voltage near infinite bus (V_b)	5.4	0.4	0.5	0.2
Current near infinite bus (I_b)	3.4	0.4	0.5	0.1

V. CONCLUSION

In this paper the power system stability enhancement of test network with FACTS devices TCSC, STATCOM and UPFC is presented and discussed under three phase short circuit fault. It is clear that the system regains its stability under any one of the FACTS device is involved. Also the settling time to reach the stability of the system with UPFC for different parameters (Generator Voltage – 1.4 secs, Generator Current – 2.3 secs, Generator Load Angle – 4.2 secs, Voltage near Infinite Bus – 0.2 secs and Current near Infinite Bus – 0.1 secs) is comparatively much better than STATCOM as well as TCSC.

REFERENCES

- [1] Dr. M. Rajaram, N. Reka, D. Murali, “Comparison of FACTS devices for power system stability enhancement,” International Journal of Computer Applications (0975 – 8887), volume 8 – No. 4, October 2010.
- [2] P. Kundur, J. Paserba, V. Ajjarapu, G. Anderson, A. Bose, C. Canizares, N. Hatziaargyriou, D. Hill, A. Stankovic, C. Taylor, T. V. Cuestem, V. Vittal, “Defenition and Classification of Power System Stability,” IEEE Transaction on Power System, 2004, 19(2)..1387 - 1401
- [3] Hadi Saadat, “Power system analysis,” TATA McGraw – Hill edition, 2002.
- [4] K. R. Padiyar, “Power System Dynamic Stability and Control,” second edition 2002, B. S. publication, Hyderabad
- [5] S. K. Srivasta, “ Advanced Power Electronics Based Facts Controllers and Overview,” Asian Power Electronics Journal, volume 4, No. 3 December 2010.

[6] Chintu Rza Makkar, Lillie Dewan, “Transient stability enhancement using robust FACTS controllers – a brief tour,” Canadian Journal on Electrical & Electronics Engineering volume 1, No. 7, December 2010.

[7] Amit Garg, Sanjay Kumar Agarwal, “ Voltage Control and Dynamic Performance of Power Transmission System using STATCOM and its Comparison with SVC”, International Journal of Advances in Engineering and Technology, January 2012.

[8] Enrique Acha, Claudio R. Fuerte – Esquivel, Hugo Ambriz – Perez, Cesar Angeles – Camacho, “FACTS Modelling and Simulation in Power Networks,” John Wiley & sons LTD, 2004.

[9] R. Mohan Mathur, Rajiv K. Varma, “Thyristor Based FACTS Controllers for Electrical Transmission Systems,” IEEE press series on Power Engineering, John Wiley & Sons LTD, 2002.

[10] S. Shankar, S. Balaji, S. Arul, “Simulation and Comparison of Various FACTS devices in power system,” International Journal of Engineering Science and Technology, volume 2 (4), 2010, 538 – 547.

[11] Alireza Seifi, Sasan Gholami, Amin Shabanpour, “Power Flow Studt and Comparison of FACTS: Series (SSSC), Shunt (STATCOM) and shunt – series (UPFC),” The Pacific Journal of Science and Technology volume 11. No. 1. May 2010 (spring).

[12] Arhithsode – Yome, N. Mithulananthan, “ Comparison of Shunt Capacitor, SVC and STATCOM in Static Voltage Stability Margin Enhancement,” International Journal of Electrical Engineering Education, 41/2.