

Optimal Placement of Dstatcom in Radial Distribution System Using Fuzzy and Penguins Search Optimization Algorithm

D Rambabu

Assistant Professor in ECE dept at Scient Engineering College ,Nadurgul, Hyderabad ,Telangana, India

Abstract: *This paper proposes a hybrid methodology to identify the optimal location and sizing for distribution static compensator (DSTATCOM) placement as a distribution flexible ac transmission system (DFACT) device in a distribution system, by using fuzzy and Penguins search optimization algorithm (PeSOA). The main purpose is to reduce the power loss and to improve the voltage profile of distribution networks. The PeSOA is meta-heuristic search method inspired from the hunting strategy of penguins. Here fuzzy is used for finding the optimal location and PeSOA is used to find the size of DSTATCOM in radial distribution networks. The feasibility and satisfying performance of the proposed method is examined on the IEEE 33-bus and 69-bus distribution system.*

Keywords: *DSTATCOM, radial distribution system, optimal placement, fuzzy approach, PeSOA.*

I. INTRODUCTION

Modern electric power systems are complex networks with multiple generating stations and load centers are interconnected with long power transmission and distribution networks. Unlike transmission systems distribution systems have high R/X ratio which results in high power loss which leads to voltage instability. Studies have indicated that as much as 13% of total power generated is wasted in the form of losses at the distribution level. In radial distribution system, providing demanding power to the entire load while maintaining voltage magnitude at an acceptable range is one of the major system constraints. There are two principal conventional means of maintaining voltages at an acceptable range in distribution systems are series voltage regulators and shunt capacitors. Conventional series voltage regulators are commonly used for voltage regulation in distribution system [1,2,3]. But these devices cannot generate reactive power and by its operation only force the source to generate requested reactive power and they have quite slow response as these operations are step by step [4]. Shunt capacitors can supply reactive power to the system but they are not capable to generate continuously variable reactive power. Another difficulty associated with the application of distribution capacitors is the natural oscillatory behavior of capacitors when they are used in the same circuit with inductive components. To overcome the problems faced by series voltage regulators and shunt capacitors concept of FACTS

devices were introduced. FACTS devices are playing a leading role in efficiently reducing the line power losses, correcting power factor and improving voltage profile of power system. Similar ideas have been applied to the distribution system. DSTATCOM (Distribution STATCOM) which is a shunt connected voltage source converter has been utilized to increase the reliability and efficiency of distribution systems.

These devices play an important role in improving voltage profile, reducing power losses etc of distribution systems under both steady state and dynamic conditions. Now a days lots of research work is carried out for finding the optimal location of FACTS devices [5-7]. Authors in [5] proposed Firefly Algorithm for optimal location and sizing of D-STATCOM. Authors in [6] determine the location and size of DSTATCOM by using particle swarm optimization algorithm. Now-a-days, lot of attention is also given to load flow analysis. Teng in [8] introduced two developed matrices BIBC and BCBV and a simple matrix multiplication is applied to obtain load flow solution. Haque [9,10] proposed the analysis for both radial and mesh networks. Unlike other methods it also includes shunt admittances. Ghosh and Das [12] presented a simple method for solving distribution networks. In this paper an effective method for improving the voltage profile and reduction of power losses is presented by placing D-STATCOM using fuzzy and PeSOA. Fuzzy approach gives the best optimal locations and then PeSOA technique optimizes the size for particular location.

II. DISTRIBUTION STATIC COMPENSATOR

The Static Synchronous Compensator (STATCOM) as member of the Flexible AC Transmission Systems (FACTS) devices is a regulating power utility which is connected to the power system in shunt mode. Once the STATCOM is used in the voltage level of distribution system is called Distribution STATCOM or shortly DSTATCOM. The DSTATCOM is a shunt connected voltage source converter which has been utilized to compensate power quality problems such as unbalanced load, voltage sag and voltage unbalance [9,10]. Fig.3.1 shows the block diagram of DSTATCOM connected to a bus in distribution system. Switch changing of VSC can absorb or generate the current by considering control strategy and depend on voltage of common coupling bus. In steady-state operation with heavy loading or some

short-circuit events, DSTATCOM typically injects appropriate compensating current to the point of coupling connection, and thus voltage at the load bus regulated by the DSTATCOM will be lifted close to the nominal or a given value. Generally, DSTATCOM has the ability of

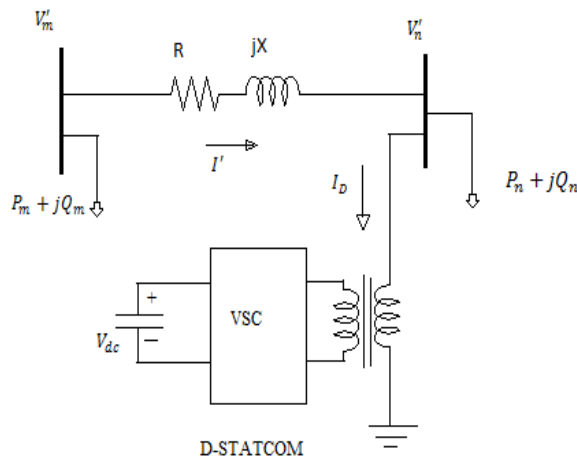
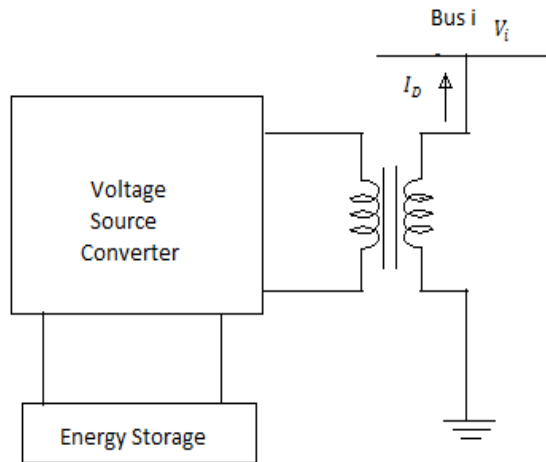

Fig.2. single line diagram of two bus distribution system with DSTATCOM

Therefore the expression for new voltage after installing DSTATCOM is given as

$$V_n \angle \theta_n' - V_m \angle \theta_m' - (R + jX)(I_m \angle \delta) - (R + jX) \left(I_D \angle \left(\frac{\pi}{2} + \theta_n' \right) \right) \quad (1)$$

Here θ_n' , θ_m' & δ are the phase angles of V_n' , V_m' & I respectively.

By separating real and imaginary parts of eqn (1) and manipulating the equations we get:

$$t = \frac{-B \pm \sqrt{D}}{2A} \quad (2)$$

exchanging active and reactive power simultaneously. The amount of active power exchanging depends on the capacity of energy source. However, in this paper DSTATCOM application for reactive power injection is considered and injection of active power is made to zero.

Fig.1. Block diagram of DSTATCOM

III. MATHEMATICAL MODELLING OF DSTATCOM

For steady state modelling of DSTATCOM, it is installed at the bus as shown in fig.2. By installing DSTATCOM the voltage values at the candidate bus and neighbouring buses changes. Let V_n' and V_m' are the new voltages at candidate bus and previous bus respectively and the line current changes to I' which is the sum of I and I_D . Where I_D is the current injected by DSTATCOM and is in quadrature with the voltage.

Where,

$$t = \sin \theta_n'$$

$$A = (ac - bd)^2 + (ad + bc)^2$$

$$B = 2(ac - bd)(V_n' \angle \delta)$$

$$C = (V_n' \angle \delta)^2 - (ad + bc)^2$$

$$D = B^2 - 4AC$$

Where,

$$a = \text{Real}(V_m' \angle \theta_m') - \text{Real}(Z I \angle \delta)$$

$$b = \text{Imag}(V_m' \angle \theta_m') - \text{Imag}(Z I \angle \delta)$$

$$c = -X$$

$$d = -R$$

Now there are two roots of t . For determining the correct value of root, the boundary conditions are examined as:

$$V_n' = V_n \Rightarrow I_D = 0 \text{ \& \ } \theta_n' = \theta_n$$

Results show that $t = \frac{B + \sqrt{D}}{2A}$ is desired root of the

equation (2). Therefore, the phase angle and magnitude of DSTATCOM current & reactive power injected to the system by the D-STATCOM are given by the expressions:

$$\angle I_D = \frac{\pi}{2} + \theta_n' = \frac{\pi}{2} + \sin^{-1} t \quad (3)$$

$$|I_D| = \frac{V_n' \cos \theta_n' - a}{-d \sin \theta_n' - c \cos \theta_n'} \quad (4)$$

$$jQ_D = (V_n' \angle \theta_n') \left(I_D \angle \left(\frac{\pi}{2} + \theta_n' \right) \right)^* \quad (5)$$

Here, * denotes complex conjugate.

IV. PROBLEM FORMULATION

The main objective of the proposed method is to reduce the total real power loss of the system under study, which is given by

$$P_{loss} = \sum_{j=1}^b I_j^2 * R_j \quad (6)$$

Where,

P_{loss} is the power loss of the system which is to be minimized.

b is the number of branches.

I_j is the current flowing through the j th branch.

R_j is the resistance of the j th branch.

Subject to constraints,

$V_i \leq V \leq V_{max}$

Where,

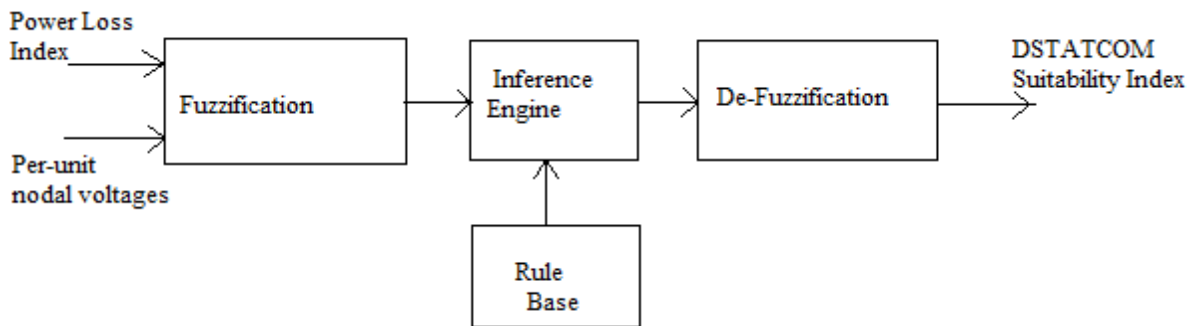

fig.3. Block diagram of Fuzzy inference system

Among the two inputs if fuzzy inference system per-unit nodal voltages are directly obtained from load flow and power loss indexes are calculated using the following equation:

$$PLI = \frac{LR_i - LR_{min}}{LR_{max} - LR_{min}} \quad (7)$$

Where,

i is the bus number

LR_i is the loss reduction at i th bus

LR_{min} and LR_{max}

are real power losses before and after the total reactive load compensation at i th node.

VI. PENGUINS SEARCH OPTIMIZATION ALGORITHM (PeSOA)

PeSOA is a new population based meta-heuristic optimization algorithm proposed by Youcef Gheraibia and Abdelouahab Moussaoui in 2013 to solve optimization problems ([15]), based on collaborative

V_i is the voltage at i th bus.

V_{min} and V_{max} are minimum and maximum voltage limits.

V. OPTIMAL LOCATIONS USING FUZZY APPROACH

Fuzzy logic is a technique generally used for quantification and processing of common language rules to arrive at a decision. All the rules are considered at once or in parallel to arrive at a weighted decision [13,14]. In this paper the basics the fuzzy logic is used for finding optimal locations of DSTATCOM by considering power loss reduction and maintaining bus voltages with in prescribed limits. Hence, power loss index(PLI) which is linearly normalized in to [0,1] and per unit nodal voltages (range [0.9,1.1]) are given as inputs to the fuzzy inference system. The output given by fuzzy inference system is DSTATCOM suitability index(DSI)(range[0,1]), and the bus with maximum DSI is the optimal location for DSTATCOM placement.

hunting strategy of penguins. Penguins are air-breathing aquatic predators and as surface is a place for penguins they are forced to return after every foraging trip. The duration of a trip is limited by the oxygen reserves of penguins. The hunting strategy of the penguins is a collaborative work of effort and timing, they benefit of their dives by optimizing the overall energy in the proseses of collective hunting and nutrition.

In the PeSOA algorithm each penguin is represented by its position and the number of fish consumed. The distribution of penguins is based on probabilities of existence of fish in a position. The penguins are divided into groups and begin to search in random positions, after a fixed number of dives, penguins return to the ice and begin to share information such as position and the amount of nutrients found. Penguins of one or more groups that have some food follow in the next dive penguins that chased a lot of fish. All penguin that represents solution is distributed in groups, and each group searches for meals at a defined place. In this

process the penguins out for the good of all groups and start searching in a specific environment based on the likelihood of food sectors, accordingly, in each cycle the position of the penguin with each new solution is adjusted using the following equation

$$X_{new} = Did + \text{rand}() | X_{best} - X_{id} | \quad (8)$$

Where:

rand() is a random number for distribution, *Did* is the last best solution accord for this penguin, *Xbest* is the best solution in the population, *Xid* is the current solution. The calculations in update solution equation are repeated for every penguin in each group, and after defined number of dives penguins communicate to each other the best solution represented by number of fish consumed.

Algorithm: Pseudo code for basic PeSOA

Generate random population of P solutions (penguins) in groups;

Initialize the probability of existence of fish in the holes and levels;

While (iteration<number of generations) do For each individual $i \in P$ do While (oxygen reserves are not depleted) do

Take a random step.

Improve the penguin position using Eqn. (8)

Update quantities of fish eaten for this penguin.

End while

End for

Update quantities of eaten fish in the holes, levels and the best group.

Redistributes the probabilities of penguins in holes and levels.

Update best-solution:

End while.

VII. RESULTS AND DISCUSSION

The proposed algorithm is tested on IEEE 33-bus and IEEE 69-bus radial distribution system using MATLAB software. Here, optimal location is obtained by using Fuzzy inference system and optimal sizing of DSTATCOM is calculated by using PeSOA, and Backward Forward Sweep load flow programming is used to solve load flow problem. Parameters used in the algorithm are, number of generations=1000, population P=50, oxygen reserves=5, and minimum and maximum sizes of DSTATCOM are taken as 0 to 0.2 per unit.

Table.1 shows the results for the proposed method for IEEE 33-bus radial distribution system, initially the total active and reactive power losses of the system are 210.99kw and 143.03kVAr. by placing the DSTATCOM of size 1258.3kVAr at bus number 30 the total active and reactive power losses are reduced to 151.3787kw and 103.819kVAr respectively, and the improvement in the voltage profiles are shown in fig.4.

TABLE I: RESULTS FOR IEEE 33-BUS SYSTEM

Discription	Without DSTATCOM	With DSTATCOM placement
Location	--	30
Size(kVAr)	--	1258.3
Total active powerloss(KW)	210.998	151.3787
Total reactive powerloss(kVAr)	143.033	103.8205
Minimum voltage(p.u)	0.9038	0.9165
%loss reduction	--	28.25

Table II: Results for IEEE 69-bus system

Discription	Without DSTATCOM	With DSTATCOM placement
Location	--	61
Size(kVAr)	--	1330.4
Total active powerloss(KW)	225.004	152.0446
Total reactive powerloss(kVAr)	102.205	70.542
Minimum voltage(p.u)	0.9092	0.9307
%loss reduction	--	32.425

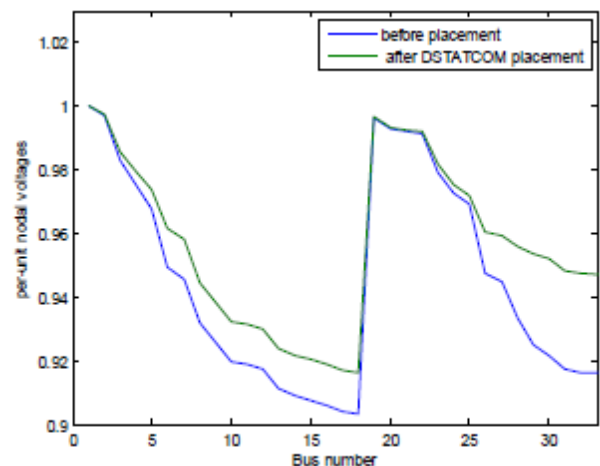

Fig.4. Voltage profiles for IEEE 33-bus system

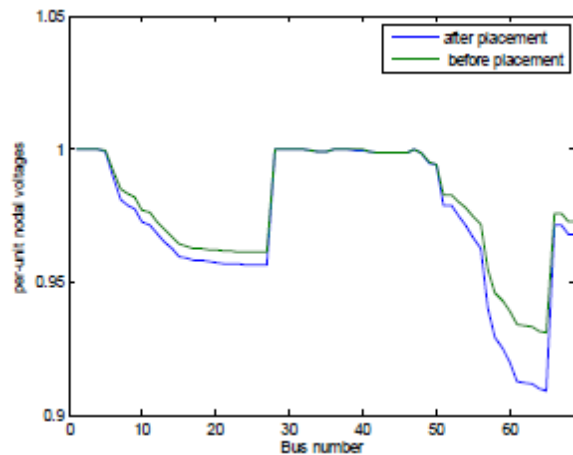

Fig.5. Voltage profiles for IEEE 69 -bus system

Table.2 shows the results for the proposed method for IEEE 69-bus radial distribution system, initially the total active and reactive power losses of the system are 225.004kw and 102.205kVAr. by placing the DSTATCOM of size 1330.4kVAr at bus number 61 the total active and reactive power losses are reduced to 152.044kw and 70.5425kVAr respectively, and the improvement in the voltage profiles are shown in fig.5.

VIII. CONCLUSION

In this paper ,two stage methodology has been presented to determine the optimal locatin and size of DSTATCOM in radial distribution system. voltage profile enhancement and minimization of active power loss are considered as objectives. Fuzzy approach is implemented to find the location and penguins search optimization algorithm is used to find the optimal sizing. The proposed methodology is tested on IEEE 33-bus and IEEE 69-bus radial distribution systems and results were analysed, and the proposed method is found to be effective and easy to implement.

REFERENCES

[1] Bishop, M.T., Foster, 1D., Down, D.A., 1994. The Application of Single-phase Voltage Regulators on Three-phase Distribution Systems. The 38th Annual Conf. on Rural Electric Power, p.C21I-C217.
[2] Gu, Z., Rizy, D.T., 1996. Neural networks for combined control of capacitor banks and voltage regulators in distribution systems. IEEE Trans. on Power Delivery, 11:1921- 1928. [doi: 10.1109/61.544277].
[3] Kojovic, L.A., 2006. Coordination of Distributed Generation and Step Voltage Regulator Operations for

Improved Distribution System Voltage Regulation. IEEE Power Engineering Society General Meeting, p.232-237.

[4] Ramsay, S.M., Cronin, P.E., Nelson, R.1, Bian, 1, Menendez, F.E., 1996. Using Distribution Static Compensators (DST ATCOMs) to Extend the Capability of Voltage-limited Distribution Feeders. The 39th Annual Conf. on Rural Electric power, p.18-24.

[5] M. Farhoodnea, A. Mohamed, H. Shareef, H. Zayandehroodi, "Optimum D-STATCOM Placement Using Firefly Algorithm for Power Quality Enhancement", IEEE 7th International Power Engineering and Optimization conference(PEOCO 2013)

[6] S. Devi, M. Geethanjali, "Optimal location and sizing determination of Distributed Generation and DSTATCOM using Particle Swarm Optimization algorithm", Electrical Power and Energy Systems, vol. 62 ,pp. 562–570, May 2014.

[7] S. M. S. Hussain, M. Subbaramiah, "An analytical approach for optimal location of D-STATCOM in radial distribution system", IEEE, 2013.

[8] J. H. Teng, "A direct approach for distribution system load flow solutions", IEEE Transactions on Power Delivery, Vol. 18, NO. 3, pp. 882-887, JULY 2003.

[9] M.H. Haque, "Efficient load flow method for distribution systems with radial or meshed configuration", IEE Proc.-Gener. Transm. Distrib. , Vol. 143, No. 1, pp. 33-38, January 1996.

[10] M.H. Haque, "A general load flow method for distribution systems", Electric Power Systems Research, vol. 54, pp. 47–54, 2000.

[11] K. Prakash, M. Sydulu, "An effective topological and primitive impedance based distribution load flow method for radial distribution systems", IEEE, DRPT, Nanjing China, pp. 1044-1049, April 2008.

[12] S. Ghosh and D. Das, "Method for load-flow solution of radial distribution networks", IEE Proc.-Gener. Transm. Distrib. , Vol. 146, No. 6, pp. 641-648, November 1999.

[13] M Damodar Reddy and V. C. Veera Reddy, Capacitor placement using fuzzy and particle swarm optimization method for maximum annual Savings, ARPN Journal of Engineering and Applied Sciences, vol. 3, No.3, June 2008.

[14]. M. Damodar reddy and N.V. Vijay kumar, Optimal capacitor placement for loss reduction in distribution system using fuzzy and harmony search algorithm, ARPN journal of Engineering and applied sciences, vol.7, No.1, January 2012, ISSN 1819-6608.

[15]. Youcef Gheraibia,Abdelouahab Moussaoui ,"Penguins Search Optimization Algorithm (PeSOA). In Recent Trends in Applied Artificial Intelligence (pp. 222-231). Springer Berlin Heidelberg", 2013.



AUTHOR

D.RAMBABU received his B.Tech in EEE in SV Institute of Technology and sciences in the year 2010 Secuderabad, Hyderabad.Dist, Telangana, and P.G.received in EEE (EPS) in Tirumala Engineering College in the year 2014 Bogaram, Keesara, R.R.Dist, Telangana, India. He is currently working as a assistant professor in EEE dept at Scient Engineering College ,Nadurgul, Hyderabad ,Telangana, India