Review Based On LOT Technology

Maraty Meena

Maratymeena@gmail.com

ABSTRACT: *-Internet of Things (IOT) has provided an opportunity to build powerful industrial system and applications by leveraging the growing ubiquity of RFID, wireless, mobile and sensor devices. Many industrial IOT applications have been increasingly developed and deployed in recent years. Now-a-days, controlling and monitoring plays a main role in our day to day life. Everything we can monitor and control using advanced technologies. Remote access is a wonderful feature that came because of high speed internet. The main objective of proposed system is to provide a technology oriented and low cost system to make an advanced industry for those who away from their industry and want to control devices.*

KEY WORDS: *- Internet of Things (IOT), Server, Raspberry Pi, Webpage, Ethernet, Smart phone etc.*

I. INTRODUCTION

Earlier there was a simple manual way of handling machines. However, with the advancement of technology, new ways are introduced for controlling the machines like automation. At the touch of a button, we can access large amount of information due to capability of computers and the Internet. Everybody wants an affordable and secure way to control their machines from any smart mobile device or Internet connection.

The Internet of Things (IoT) is the network of physical objects or "things" embedded with electronics, software, sensors and connectivity to enable it to achieve greater value and service by exchanging data with the manufacturer, operator or other connected devices. Each thing is uniquely identifiable through its embedded computing system but is able to interoperate within the existing Internet infrastructure.

Internet of Things is the next big revolution of the world on digitalization of commercializing various modules/products. Everything is associated with the internet, some involves controlling and some involves monitoring the parameters from anywhere. The Internet of Things is today's most trending technology that stands alongside wearables and robotics.

A printed circuit board (PCB) is the basic part in industry for manufacturing of any electronic product.

Etching is main process for developing a PCB. In etching machine, the etchant solution is distributed over the boards by nozzles and recirculated by pumps. Adjustment of the nozzle, temperature and etchant composition gives predictable control of etching rates and high production rate. Etching at ambient temperature might take over an hour, so it is better to heat up the etching solvent to about 35-45 degree celcius. At higher temperatures the etching performance decreases, so it is necessary to control the temperature of solvent. So the proposed system continuously monitors the machine and at a specific condition it will take necessary action.

II. LITERATURE SURVEY

Li Da Xu, Wu He, and Shancang Li [1]: This paper reviews the current research of IoT, key enabling technologies, major IoT applications in industries, and identifies research trends and challenges. A main contribution of this review paper is that it summarizes the current state-of-the-art IoT in industries systematically.

Earlier there was a simple manual way of handling machines. However, with the advancement of technology, new ways are introduced for controlling the machines like automation. At the touch of a button, we can access large amount of information due to capability of computers and the Internet. Everybody wants an affordable and secure way to control their machines from any smart mobile device or Internet connection.

The Internet of Things (IoT) is the network of physical objects or "things" embedded with electronics, software, sensors and connectivity to enable it to achieve greater value and service by exchanging data with the manufacturer, operator or other connected devices. Each thing is uniquely identifiable through its embedded computing system but is able to interoperate within the existing Internet infrastructure.

Internet of Things is the next big revolution of the world on digitalization of commercializing various modules/products. Everything is associated with the internet, some involves controlling and some involves monitoring the parameters from anywhere. The Internet of Things is today's most trending technology that stands alongside wearables and robotics.

A printed circuit board (PCB) is the basic part in industry for manufacturing of any electronic product. Etching is main process for developing a PCB. In etching machine, the etchant solution is distributed over the boards by nozzles.

AlaaAlhamoud, Felix Ruettinger, Andreas Reinhardt, Frank Englert, Daniel Burgstahler, Doreen Bohnstedt, Christian Gottron and Ralf Steinmetz [2]: This paper presents framework for realizing energy efficient smart homes based on wireless sensor networks and human activity detection. Their work is based on the idea that most of the user activities at home are related to a set of electrical appliances which are necessary to perform these activities.

Therefore, they show how it is possible to detect the user's current activity by monitoring his fine-grained appliance-level energy consumption. This relation between activities and electrical appliances makes it possible to detect appliances which could be wasting energy at home. Our framework is organized in two components. On one hand, the activity detection framework which is responsible for detecting the user's current activity based on his energy consumption.

Kemal Akkaya, Ismail Guvenc, Ramazan Aygun, Nezh Pala and Abdullah Kadri [3]: This paper surveys the existing works on occupancy monitoring and multi-modal data fusion techniques for smart commercial buildings. The goal is to lay down a framework for future research to exploit the spatio-temporal data obtained from one or more of various IoT devices such as temperature sensors, surveillance cameras, and RFID tags that may be already in use in the buildings.

Andrea Zanella, Nicola Bui, Angelo Castellani, LorenzoVangelista, and Michele Zorzi [4]: This paper focuses specifically to an urban IoT system that, while still being quite a broad category, are characterized by their specific application domain. Urban IoTs, in fact, are designed to support the Smart City vision. This aims at exploiting the most advanced communication technologies to support added-value services for the administration of the city and for the citizens. This paper hence provides a comprehensive survey of the enabling technologies, protocols, and architecture for an urban IoT.

Ala Al-Fuqaha, Mohsen Guizani, Mehdi Mohammadi, Mohammed Aledhari, and Moussa Ayyash [5]: This paper provides an overview of the Internet of Things (IoT) with emphasis on enabling technologies, protocols, and application issues. The IoT is enabled by the latest

developments in RFID, smart sensors, communication technologies, and Internet protocols. The basic premise is to have smart sensors collaborate directly without human involvement to deliver a new class of applications. The current revolution in Internet, mobile, and machine-to-machine (M2M) technologies can be seen as the first phase of the IoT. In the coming years, the IoT is expected to bridge diverse technologies to enable new applications by connecting physical objects together in support of intelligent decision making. This paper provides a horizontal overview of the IoT. Then give an overview of some technical details that pertain to the IoT enabling technologies, protocols, and applications. Compared to other survey papers in the field, our objective is to provide a more thorough summary of the most relevant protocols and application issues.

III. PROPOSED WORK

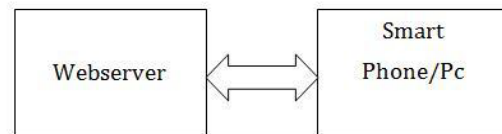

Fig 1: Server block diagram

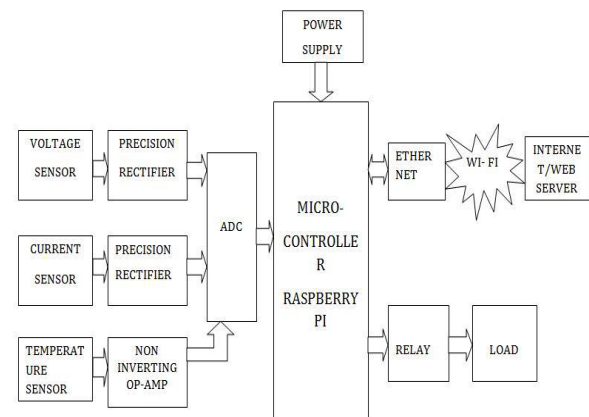

Fig2: Client block diagram

The entire system is composed of two parts: Server and Client. When power supply is given, sensors starts sensing the corresponding parameters. The data collected by sensors is conditioned and amplified to interface it with Raspberry-Pi system. Simultaneously the sensed values uploaded onto webpage. The authorized person can access the data from any place at any time, monitor the parameters and control the load through IOT successfully.

The authorized person can login by using username and password. If username and password is correct then and then only user can monitor and control the machine. Maintenance is one of the major issue in industry. The voltage and current of induction motor can be calculated by using voltage sensor and current sensor. By using this parameters power consumption can be calculated and according to that indication is given. Green signal for no maintenance, orange signal for maintenance is require within 10-15 days, red signal for maintenance require. When power exceeds particular level then the motor gets automatically turn off. Temperature sensor is used to monitor the temperature of solvent and control the heater in the machine. When temperature goes beyond particular temperature the heater gets automatically turn off. The Webpage is used to monitor and control of machine using the data collected by Raspberry Pi platform.

Raspberry- Pi: These boards contain the ARM11 IC. ARM11 processor (Raspberry Pi) plays a key role in monitoring the system. Low-power consumption ARM11 processor (Raspberry Pi) operating at 3.3-5V, 50uA – 1A is designed and mounted on a PCB along with reset circuit and clock circuit. ARM11 is 32-bit processor with RISC architecture and having 40 GPIO with 8GB SD Card and 512 Bytes of RAM associated with this raspberry pi.

Temperature Sensor: Temperature sensor is used to monitor the temperature of chemical, which is used for etching purpose. When temperature exceeds particular temperature then the heater gets automatically off.

Current sensor: Current transformer is sensor used to linearly step down the sensor to a lower level compatible with measurement instrumentation. The core of a current transformer is toroidal, or ringed, in shape with opening in the center. The number of wire winding around the core dictates the step down ratio, between the current in measured line, and the current output connected to the instrumentation.

Voltage sensor: Voltage transformer is sensor used to linearly step down the sensor to a lower level compatible with measurement instrumentation. The number of wire winding around the core dictates the step down ratio, between the voltage in measured line, and the voltage output connected to the instrumentation.

Webpage: HTML is a specific type of universal language used for decorating a web page. HTML stands for

Hypertext Markup Language. Hypertext is the text that has been used up with extra specifications such as formatting, Image multimedia etc.

Relay: Relay is a device which allows low power circuit to switch a relatively high current/voltage and controlling the actions performed. Designing this on PCB we are connecting the appliances like bulb, DC motor etc.

IV. CONCLUSION

The monitoring and controlling of machines in industry has become a major problem. By surveying all above reference papers most of the work done related to home automation. The proposed system take few parameters related to industry and provide facility related to that .The proposed system enables us to monitor and control machines from remote places as well as gives information regarding the maintenance. This kind of system useful because Human can make mistakes and forgot to switch off the machine at specific condition.

REFERENCES

- [1] Li Da Xu, Wu He, and Shancang Li, "Internet of Things in Industries: A Survey" IEEE transactions on industrial informatics, vol. 10, no. 4, November 2014.
- [2] Alaa Alhamoud, Felix Ruettiger, Andreas Reinhardt, Frank Englert, Daniel Burgstahler, Doreen Bohnstedt, Christian Gottron and Ralf Steinmetz, "SMARTENERGY.KOM: An Intelligent System for Energy Saving in Smart Home", 3rd IEEE international workshop on global trends 2014.
- [3] Kemal Akkaya, Ismail Guvenc, Ramazan Aygun , Nezih Pala, Abdullah Kadri, " IOT-based Occupancy Monitoring Techniques for Energy-Efficient Smart Buildings" ,2015 IEEE wireless communication and networking conference.
- [4] Andrea Zanella, Nicola Bui, Angelo Castellani, Lorenzo Vangelista, and Michele Zorzi, "Internet of Things for Smart Cities" IEEE Internet of things journal , Vol. 1 , No. 1 , FEBRUARY2014.
- [5] Ala Al-Fuqaha, Mohsen Guizani, Mehdi Mohammadi, Mohammed Aledhari, and Moussa Ayyash, "Internet of Things: A Survey on Enabling Technologies, Protocols, and

Applications”,IEEE communication surveys & tutorials, vol. 17, no. 4, fourth quarter 2015.

- [6] Nagender Kumar Suryadevara, Subhas Chandra Mukhopadhyay, Sean Dieter Tebje Kelly, and Satinder Pal Singh Gill ,”WSN-Based Smart Sensors and Actuator for Power Management in Intelligent Buildings” IEEE/ASME transactions on mechatronics, vol. 20, no. 2, april 2015.
- [7] Dan D. Koo, John J. Lee, Aleksei Sebastiani, and Jonghoon Kim,” An Internet-of-Things (IoT) system development and implementation for bathroom safety enhancement”International Conference on Sustainable Design, Engineering and Construction, Sciencedirect Procedia Engineering 145 (2016) 396 – 403.
- [8] Vinay M, Shivashankar s k,”Monitoring And Controlling Of Smart Equipments In Manufacturing Industry Using Iot Applications”,International Journal of Technical Research and Applications e-ISSN: 2320-8163, www.ijtra.com Volume 4, Issue 3 (May-June, 2016), PP. 96-100.

AUTHOR1



MARATY MEENA received her B.Tech in ECE in Gokaraju Rangaraju Institute of Technology and sciences in the year 2006 Miyapur, R.R.Dist, Telangana, and P.G.received in ECE (VLSI and Embedded) in Vivekananda Institute of Technology and Sciences in the year 2016 Bogaram, Keesara, R.R.Dist, Telangana, India.