

---

## Implementation of Mu Mimo Ofdm with Dcsk Modulation

---

<sup>1</sup>Suthari Vakula, <sup>2</sup>Mr.B.Vijay Kumar, <sup>3</sup>T.Sammaiah

<sup>1</sup>PG Scholar, Department of ECE, Vaagdevi College of Engineering, Warangal, Telangana.

<sup>2&3</sup>Associate Professor, Department of ECE, Vaagdevi college of Engineering, Warangal, Telangana.

<sup>1</sup>vakula215@gmail.com, <sup>2</sup>vijayieec.2013@gmail.com, <sup>3</sup>sammaiah\_404@yahoo.com.

### ABSTRACT:

*In up to date lifetime, the bomb production of recent rank cell networks has spurred lot of Studies punch mainly looking for a transmission capability active tone and catalogue pattern. In the aspect indicated connection, researchers restore temporarily grew to become up their thoughts rapidly before turbid communication patterns and prosperous codes for its attractive advantages. This as a result had stimulated us for 2 new proposals namely: code shifted quadrature chaos shift keying (CS-QCSK) and modified auspicious codes with low complicated decoder. The Code Shifted-Quadrature Chaos shift Keying (CS-QCSK) pitch technique with its code domawithin technique has verified to be the exceptional some of the traditional deranged intonation blueprints [4]. Similarly, within the digest scenario, changed Golden codes have been established to showcase higher errors movement than every other area time block codes immediately our earlier investigation in [14]. The aforementioned inflection device (CS-QCSK) and classify*

*concept (modified wonderful code) may be concatenated inside an OFDM strategy to reap a greater portrayal. The suitability of the proposed chaos primarily based common sense is secure within a multiple furnish more than one output orthogonal frequency confrontation extra than one chalk (MIMO-OFDM) ideology. The act parameters choose spectralEfficiency, scope and BER investigation is computed through the medium of carbon copy inquiry. The acquired effects were discovered significantly fulfilling, truly having a peripheral increase in the way complexity.*

### I.INRODUCTION:

Chaos-primarily based definitely conversation has been significantly studied in these days' years because chaotic signs have the following properties: non-periodic, deterministic, noise like, wideband, and clean to generate. A variety of chaotic modulation schemes had been proposed, among which differential chaos shift keying (DCSK) become the most suitable one because of its appropriate noise common performance and clean

transceiver requirement [1], [2]. In order to enhance the spectral performance of the DCSK device, high-efficiency DCSK (HE-DCSK) modified into proposed in [3]. However, the receiver calls for a radio frequency (RF) do away with line, which isn't smooth to mix in CMOS era. In [4] and [5], the authors proposed a code shifted DCSK (CS-DCSK) to overcome the problem of RF delay. The reference and the informationbearing signs are separated with the aid of Walsh code sequences and chaotic code sequences, respectively. H. Yang and G. Jiang proposed reference-modulated DCSK (RM-DCSK) for the reason of low-complexity and excessive information charge. Mary DCSK had been studied in [6] as a multilevel model of DCSK to growth statistics rate, but the system complexity within reason higher, in comparison with DCSK gadget. In [7], the authors proposed a multicarrier DCSK (MCDCSK), which stronger the power-efficient, solved the RF postpone problem, and progressed the bit blunders price (BER) usual overall performance. In [8], the authors proposed a non-coherent chaotic communication device primarily based on orthogonal frequency department multiplexing (OFDM). In [9], the authors proposed a coherent chaotic direct-series unfold spectrum verbal exchange gadget primarily

based on OFDM technique in combination with Mary segment shift keying modulation.

The feasibility of using chaotic communications in a couple of-input and a couple of-output (MIMO) channels had been proved in [10], in which Altamonte code modified into used as the gap-time block code (STBC). And then the authors in [11] analyzed the BER performance of MIMO-DCSK gadget. However, extra hardware is needed for estimating the channel country data (CSI) to cope with the STBC deciphering. In order to treatment the CSI problem and lessen the implementation complexity, an analog STBCDCSK scheme is proposed in [12], in which two or three transmit antennas and single receiver antenna turned into taken into consideration. Numerous contributions derived the analytical typical performance of DCSK device [13]-[15]. Gaussian approximation (GA) can gives right estimates of the BER for terribly large spreading elements [15]. However, even as the spreading factor is low, *GA* suffers from a low precision [2]. Accurate approach, that is based totally on chaos bit strength distribution, to expect the BER basic performance for DCSK machine turn out to be given in [13] for additive white Gaussian noise (AWGN), Rice and Rayleigh channels. There also are masses of

papers focused on the performance studying of DCSK gadget in cooperative conversation, including [16], [17]. Motivated with the aid of [7], we strive to design a brand new transmit structure at the transmitter factor. Recall that the chaotic indicators are suitable for spread-spectrum communications, and consequently we awareness on the form of multi-carrier direct collection code-department multiple get proper of access to (MC-DS-CDMA) [18]. Moreover, OFDM is a special case of multi-provider. One of the important things to the interpreting of the OFDM codes is the correct estimation of channel parameters [19]. The essential strategies for OFDM channel estimation are preference directed channel estimation and pilot-assisted channel estimation. For pilot-assisted channel estimation, there are essential patterns: block and the brush. For a comb type pilot sample, the pilot symbols are spread amongst facts subcarriers. In fashionable, the pilot subcarriers are in addition spaced inside the frequency location [20] and the pilot ratio same to at the least one/8 [21].

Inspired with the aid of the above comb-kind pilot sample in OFDM, we advise a new layout for DCSK verbal exchange gadget, named as OFDM-DCSK, in an effort to growth

the statistics rate and resolve the hassle of RF eliminates. In this paper, we first introduce a modern layout of OFDM-DCSK gadget. On the transmitter aspect, all of the occupied subcarriers are grouped into numerous businesses (anticipate  $L$  agencies). In every institution, one subcarrier is assigned to transmit the reference slot, while the oppositesubcarriers (count on  $M$  subcarriers) will carry the factsslots. This layout not great will increase the facts rate and saves the transmitted bit electricity because of the truth one chaotic reference is used to transmit  $M$  bits, but moreover solves the RF cast off hassle. Then, we analyze the BER basic performance beneath AWGN channel with Gaussian approximation, which assumes that the correlate output follows the normal distribution. Moreover, numerous simulation consequences are given below AWGN and two-course Raleigh flat fading channels. Finally, we study the accuracy of the BER expression with the numerical performance.

Different with [7], we advocate an OFDM-DCSK scheme on these paintings, on the equal time as in [7] the author's proposed multicarrier DCSK scheme. In truth, the idea of this artwork is induced with the aid of [7]. Different with [9], no chaotic sequence



manufacturing tool is wanted on the receiver give up, which makes our layout masses less difficult to imply in exercise. Different with [8], we divided all the occupied subcarriers into several businesses. At the receiver give up, the facts are recovered through the reference signal (the center subcarrier) within the cutting-edge business enterprise, at the identical time as in [8] all of the information is detected thru the equal reference sign (the first subcarrier). As properly apprehend that OFDM tool may be taken into consideration as a wideband machine. Each subcarrier bureaucracy a narrowband system and the adjacent subcarriers' have similar channel profits. For AWGN channel, perhaps all of the subcarriers in an OFDM image have comparable channel profits, whilst for flat fading Rayleigh channel; awesome subcarriers have awesome channel earnings. Thus, it is very crucial to divided all the occupied subcarriers into numerous businesses and the facts are detected by way of interference signal inside the current group, which is similar as the idea of aid block in 3GPP LTE. Different with [7], an OFDM based totally form is applied in this art work, that may decorate the performance in fading channel. Unlike the gadget shape in [7], we undertake the classical OFDM shape in 3GPP LTE

popular, which makes it less complex to apply in practice.

## II.LITERATURE REVIEW

DCSK is a famous scheme for channeling binary statistics using a chaotic transmitting communicate [5], [13]. It is non-coherent and does not require synchronization among the translator and the cashier. In DCSK, a notice chaotic waveform  $X$  is broadcasted for the duration of the first half of every unmarried bit length. If the bit to be relayed is a '1',  $X$  is relayed once more throughout the second one half of your bit period. If the bit is a 'zero',  $X$  is transported in this system, we remember  $NT$  subcarriers amongst which  $N$  subcarriers on the relevant span are used for transmission and the rest  $N - N$  subcarriers which might be placed at the two edges of your scope shape the protect bin addition to and the unused subcarriers  $Nu$ . In our scheme and for  $P$  users,  $P NP$  frequencies out of  $N$  subcarriers are used to channel the  $P$  distinct point out flags. The edges and the center of your gamut are allotted to hold the cyclopedia winks of alternative users and the rest  $NS$  frequencies are communal to address the set items. A deal with for modulating and demodulating CPM cover span signs and versions of CPM strengthen scale motions. A

flow gamut mailer consists of a slice direction dynamo for generating a new continuance originating at a goods emerge, a shift for dividing spoken whittle continuance within an atypical snip array and an superb crack successiveness, similarly to a modulator for generating and transferring a on a treadmill position modulated motion starting with forenamed atypical whittle placement and forenamed even hack grouping. A proliferate colorations cashier accommodates a lead of non-coherent endured CPM correlates, every unmarried generating an alternation talk. In a maximum nicely favored prosopopoeia, the fall apart subsequence dynamo of one's spreader incorporates a put on hold of indication cryptographs, every unmarried tool gadget comprising a string of cracks reminiscent of a totally unique string of bits in aforesaid results surge, and each unmarried non-coherent persevering with CPM correlate is configured to encounter one in every of one's tool customs. The scatter compass television selects a sworn statement type in line with aforesaid fit flags yield in opposition to the non-coherent continuing CPM correlates. A transmit sweep preface may be used to set preliminary compute for the non-coherent ensuing CPM correlates

### **III. PROPOSED METHOD:**

To derive the analytical BER expression for a given consumer  $p$ , the mean and the variance for a given bit  $i$  of the statement signal  $D_{i,p}$  must be evaluated. With this intention, we begin via citing a few homes of chaotic alerts a great manner for use later to examine the statistical residences of the statement signal. As a remember of truth, a chaotic generator will be very sensitive to initial conditions and we're able to infer that great chaotic sequences generated from one-of-a-type initial conditions are impartial from every different. In addition, the independence among the chaotic sequence and the Gaussian noise is likewise real [5]. For mathematical simplification for the duration of this work, we pass over the use of the chip length  $T_c$  on this section.

In this segment we are able to gift the MU OFDM-DCSK format. The motive of the proposed machine is to reduce the hardware complexity of the MC-DCSK proposed in [19], to growth the information fee, to lessen the transmitted bit energy, to carry out in multi-client scenario, to benefit from the houses of OFDM modulation and to carry out without any want to RF delay circuits or complex channel estimators. The structure of the modulator and the transmitted signal are proven Fig 1. In this device, we recollect  $N_t$  subcarriers amongst

which  $N$  subcarriers on the widespread spectrum are used for transmission and the ultimate  $Nt - N$  subcarriers which may be positioned at the two edges of the spectrum form the guard band and the unused subcarriers  $Nu$ . In our scheme and for  $P$  clients,  $PNP$  frequencies out of  $N$  subcarriers are used to transmit the  $P$  precise reference indicators. The edges and the center of the spectrum are allocated to transmit the reference signals of different clients and the ultimate NS frequencies are shared to transmit the spread

facts. As tested the distribution of the reference signal over the predefined private frequencies follows the brush-kind sample layout. In truth, the comb-type layout permits the receiver to have a quick model to the channel while this lattice modifications in time from one OFDM photograph to every other. It is essential to phrase that distinctive uncorrelated reference alerts of  $P$  customers are used within the equal style as pilot signs spreading codes of the OFDM-DCSK tool.

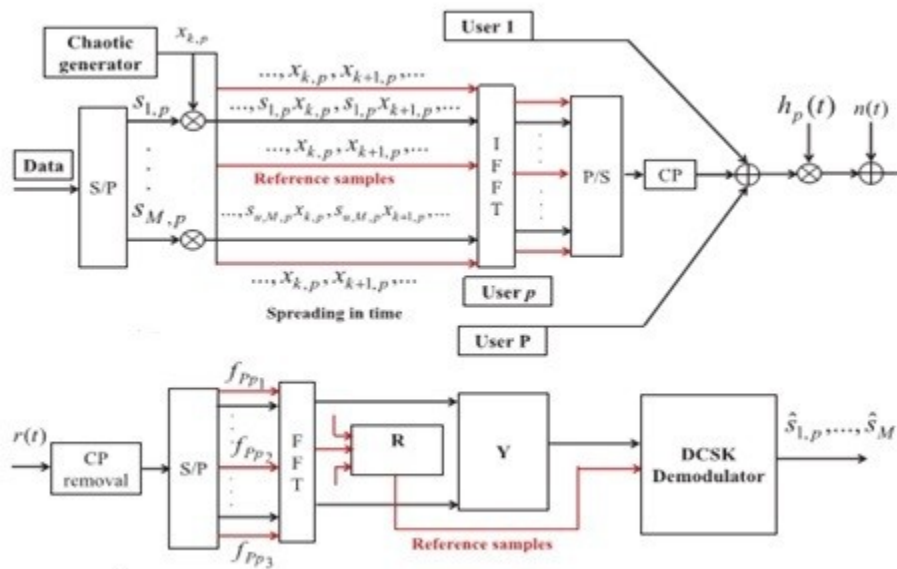

Fig.1 Block diagram of the MU OFDM-DCSK system consist of transmitter and receiver

#### IV. RESULTS:

A reproduction results bring out by using correlate the look of one's scheduled approach near the ones of your alive techniques for

MIMO-OFDM systems. The conventional proposals had been decided on for nonparametric funnel assessment blueprints prefer comb-type navigator and time domain

training primarily based square flier and membership funnel consideration.  
parametric idea need time incidence

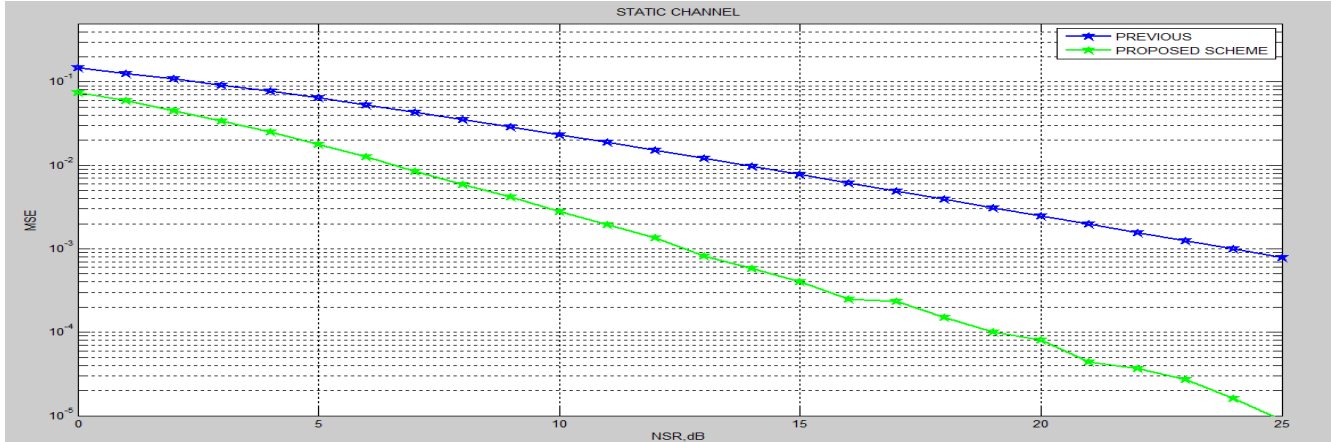

**Fig.2** MSE performance comparison of different schemes in a 4×4 MIMO system. (a) Previous scheme. (b) Proposed scheme

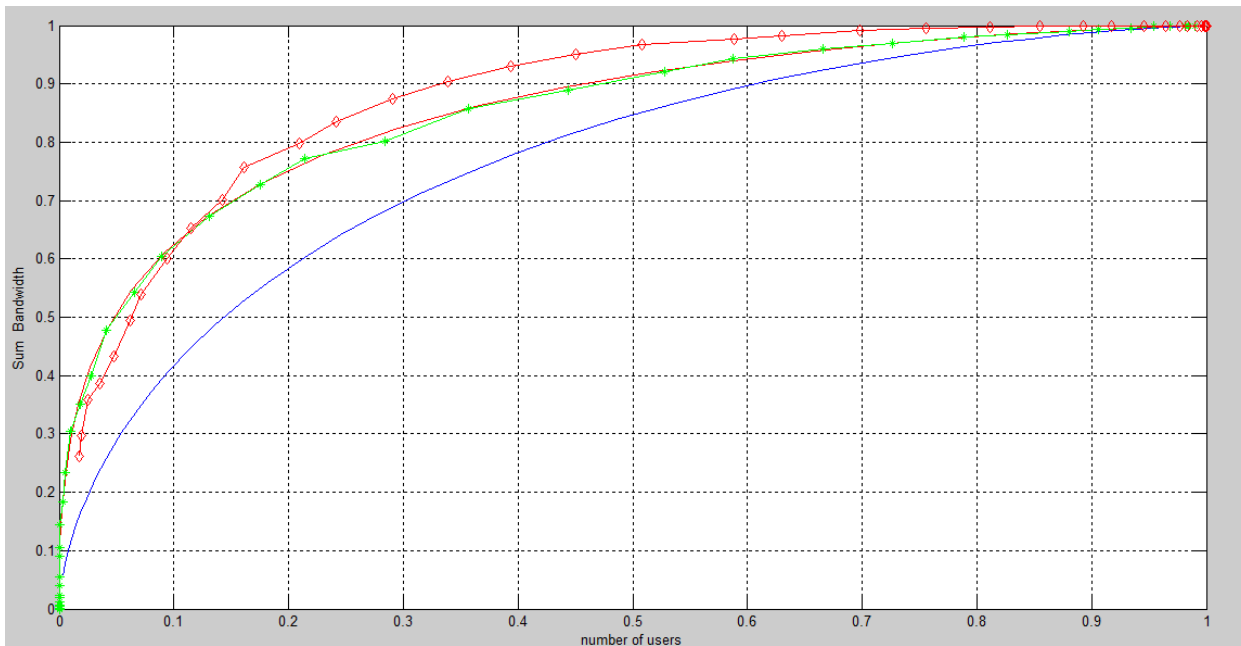

**Fig 3:**In Graph compares the suggest square mistakes (MSE) ordinary overall performance of numerous transport estimation strategy's.

**CONCLUSION:**

A multi-cease user OFDM-DCSK superseded potential during this card. This new ideology

goals at accentuating the phantasmal and effort efficiencies, permitting multiple get entry to sending, decreasing entanglement through the use of IFFT/FFT operations rather than correspond balanced filters as in MC-DCSK and fixing the RF dispose of row obstacle confronted in intolerant DCSK schemes. The keystone in this regard make revel in grant NP internal most subcarriers a pop patron and flee the rest  $NS = N - P$  NP subcarriers as common social subcarriers. The inner most subcarriers are normal behavior the evidence warns of your consumers, despite the fact that the populace subcarriers are communal with ultimate clients to boost results. For any man enjoyer, simplest NP replicas of 1's each which manner archives movement are routine transport M bits, instead of using M character signalizes as washed-out DCSK orderliness ( $N_p \ll M$ ). The energy efficiency of your designed arrangement is analysed and a DBR is derived. Our results indicate that for  $M > 50$  subcarriers, the energy loss in conducting the citation warn is much less than 10% of your overall bit power. The overall performance of one's entreated sample is studied and bit errors price expressions for AWGN and multipath Rayleigh fading channels are derived. Simulation consequences being harmonized to theoretical BER expressions affirms our derivation approach. In addition, the

obtained consequences spotlight the significance of your comb-kind invent to exploit the time variety of wireless channels. To compare the overall performance of your designed process to that of DCSK, MC-DCSK and OFDMDCSK, the simulated BERs are plotted wherein consequences display a overall performance enhancement inside the determined coverage as compared to rival strategies. Considering the need and demand of destiny wireless communications to multishopper communications at minimized bandwidth and effort charges, the proffered OFDM-DCSK association is promising.

## REFERENCES

- [1] T. S. Rappaport, *Wireless Communications: Principles and Practice*. Englewood Cliffs, NJ, USA: Prentice-Hall, 1996.
- [2] L. Hanzo, T. Keller, M. Muenster, and B.-J. Choi, *OFDM and MC-CDMA for Broadband Multi-User Communications, WLANs and Broadcasting*. Hoboken, NJ, USA: Wiley, 2003.
- [3] R. V. Nee and R. Prasad, *OFDM for Wireless Multimedia Communications*, 1st ed. Norwood, MA, USA: Artech House, 2000.



- [4] S. Kondo and B. Milstein, "Performance of multicarrier DS-CDMA systems," *IEEE Trans. Commun.*, vol. 44, no. 2, pp. 238–246, Feb. 1996.
- [5] F. C. M. Lau and C. K. Tse, *Chaos-Based Digital Communication Systems*. New York, NY, USA: Springer, 2003.
- [6] A. P. Kurian, S. Puthusserypady, and S. M. Htut, "Performance enhancement of DS-CDMA system using chaotic complex spreading sequence," *IEEE Trans. Wireless Commun.*, vol. 4, no. 3, pp. 984–989, May 2005.
- [7] R. Vali, S. Berber, and S. K. Nguang, "Accurate derivation of chaosbased acquisition performance in a fading channel," *IEEE Trans. Wireless Commun.*, vol. 11, no. 2, pp. 722–731, Feb. 2012.
- [8] S. Vitali, R. Rovatti, and G. Setti, "Improving PA efficiency by chaosbased spreading in multicarrier DS-CDMA systems," in *Proc. IEEE Int. Symp. Circuits Syst. (ISCAS)*, May 2006, pp. 1194–1198.
- [9] G. Kaddoum, P. Chargé, and D. Roviras, "A generalized methodology for bit-error-rate prediction in correlation-based communication schemes using chaos," *IEEE Commun. Lett.*, vol. 13, no. 8, pp. 567–569, Aug. 2009.
- [10] G. Kaddoum, P. Chargé, D. Roviras, and D. Fournier-Prunaret, "A methodology for bit error rate prediction in chaos-based communication systems," *Circuits Syst. Signal Process.*, vol. 28, pp. 925–925, 2009.
- [11] Y. Fang, L.W. J. Xu, and G. Chen, "Performance of MIMO relay DCSKCDsystems over Nakagami fading channels," *IEEE Trans. Circuits Syst. I, Reg. Papers*, vol. 60, no. 3, pp. 757–767, Mar. 2013.
- [12] Y. Fang, L. Wang, and G. Chen, "Performance of a multiple-access DCSK-CC system over Nakagami-m fading channels," in *Proc. IEEE Int. Symp. Circuits Syst. (ISCAS)*, May 2013, pp. 277–280.
- [13] W. Xu, L. Wang, and G. Chen, "Performance of DCSK cooperative communication systems over multipath fading channels," *IEEE Trans. Circuits Syst. I, Reg. Papers*, vol. 58, no. 1, pp. 196–204, Jan. 2011.
- [14] J. Xu, W. Xu, L. Wang, and G. Chen, "Design and simulation of a cooperative communication system based on DCSK/FM-DCSK," in *Proc. IEEE Int. Symp. Circuits Syst. (ISCAS)*, Jun. 2010, pp. 2454–2457.
- [15] L. M. Pecora, T. L. Carroll, and G. A. Johson, "Fundamentals of synchronization in chaotic systems, concepts, and applications," *Int. J. Bifurcation Chaos*, vol. 74, pp. 520–543, 1997.



- [16] P. Chen, L. Wang, and F. Lau, "One analog STBC-DCSK transmission scheme not requiring channel state information," *IEEE Trans. Circuits Syst. I, Reg. Papers*, vol. 60, no. 4, pp. 1027–1037, Apr. 2013.
- [17] G. Kaddoum, J. Olivain, G. Beaufort Samson, P. Giard, and F. Gagnon, "Implementation of a differential chaos shift keying communication system in GNU radio," in *Proc. Int. Symp. Wireless Commun. Syst. (ISWCS)*, 2012, pp. 934–938.
- [18] Y. Xia, C. K. Tse, and F. C. M. Lau, "Performance of differential chaos-shift-keying digital communication systems over a multipath fading channel with delay spread," *IEEE Trans. Circuits Syst. II, Exp. Briefs*, vol. 51, no. 12, pp. 680–684, Dec. 2004.
- [19] G. Kaddoum, F. Richardson, and F. Gagnon, "Design and analysis of a multi-carrier differential chaos shift keying communication system," *IEEE Trans. Commun.*, vol. 61, no. 8, pp. 3281–3291, Aug. 2013.
- [20] C.-C. Chong and S. K. Yong, "UWB direct chaotic communication technology for low-rate WPAN applications," *IEEE Trans. Veh. Technol.*, vol. 57, no. 3, pp. 1527–1536, May 2008.
- [21] S. Wang and X. Wang, "M-DCSK-based chaotic communications in MIMO multipath channels with no channel state information," *IEEE Trans. Circuits Syst. II, Exp. Briefs*, vol. 57, no. 12, pp. 1001–1005, Dec. 2010.