Design of FPGA Logic Architectures using Hybrid/LUT Multiplexer

Mohd Abdul Sumer

Assistant Professor, Department of ECE, Sana Engineering College, Kodad
(MN), Suryapet (Dist), Telangana, India.

Abstract: Hybrid configurable logic block architectures for field-programmable gate arrays that contain a mixture of lookup tables and hardened multiplexers are evaluated toward the goal of higher logic density and area reduction. Multiple hybrid configurable logic block architectures, both nonfracturable and fracturable with varying MUX:LUT logic element ratios are evaluated across two benchmark suites (VTR and CHStone) using a custom tool flow consisting of LegUp-HLS, Odin-II front-end synthesis, ABC logic synthesis and technology mapping, and VPR for packing, placement, routing, and architecture exploration. VPR is used to model the new hybrid configurable logic block and verify post place and route implementation. In this paper experimentally, we show that for nonfracturable architectures, without any mapped optimizations, we naturally save up to ~8% area post place and route. For fracturable architectures, experiments show that only marginal gains are seen after place-and-route up to ~2%. For both nonfracturable and fracturable architectures, we see minimal impact on timing performance for the architectures with best area-efficiency.

Keywords— FPGA, Multiplexer logic element, Complex logic block, mapping technologies

I. INTRODUCTION

A field-programmable gate array (FPGA) is a block of programmable logic that can implement multi-level logic functions. FPGAs are most commonly used as separate commodity chips that can be programmed to implement large functions. However, small blocks of FPGA logic can be useful components on-chip to allow the user of the chip to customize part of the chip's logical function. An FPGA block must implement both combinational logic functions and interconnect to be able to construct multi-level logic functions. There are several

different technologies for programming FPGAs, but most logic processes are unlikely to implement anti-fuses or similar hard programming technologies.

Throughout the history of field-programmable gate arrays (FPGAs), lookup tables (LUTs) have been the primary logic element (LE) used to realize combinational logic. A K-input LUT is generic and very flexible able to implement any K-input Boolean function. The use of LUTs simplifies technology mapping as the problem is reduced to a graph covering problem. However, an exponential area price is paid as larger LUTs are considered. The value of K between 4 and 6 is typically seen in industry and academia, and this range has been demonstrated to offer a good area/performance compromise. Recently, a number of other works have explored alternative FPGA LE architectures for performance improvement to close the large gap between FPGAs and application-specific integrated circuits (ASICs)

A. LOOKUP TABLES

The basic method used to build a combinational logic block (CLB) also called a logic element in an SRAM-based FPGA is the lookup table (LUT). As shown in Figure, the lookup table is an SRAM that is used to implement a truth table. Each address in the SRAM represents a combination of inputs to the logic element. The value stored at that address represents the value of the function for that input combination. An n-input function requires an SRAM with locations.

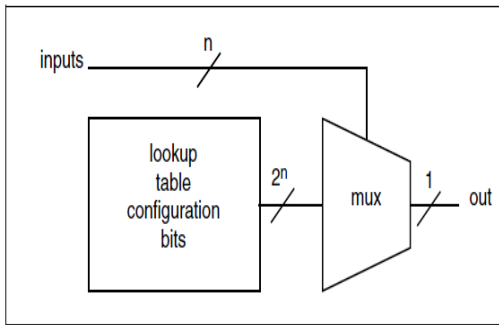

Fig -1 Lookup Tables

Because a basic SRAM is not clocked, the lookup table logic element operates much as any other logic gate as its inputs changes, its output changes after some delay.

B. PROGRAMMING A LOOKUP TABLE

Unlike a typical logic gate, the function represented by the logic element can be changed by changing the values of the bits stored in the SRAM. As a result, the n-input logic element can represent functions (though some of these functions are permutations of each other).

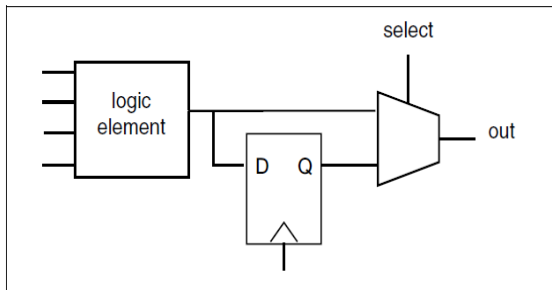

Fig-2

Programming A Lookup Table

A typical logic element has four inputs. The delay through the lookup table is independent of the bits stored in the SRAM, so the delay through the logic element is the same for all functions. This means that, for example, a lookup table-based logic element will exhibit the same delay for a 4-input XOR and a 4-input NAND. In contrast, a 4-input XOR built with static CMOS logic is considerably slower than a 4-input NAND. Of course, the static logic gate is generally faster than the logic element. Logic elements generally contain registers flip-flops and latches as well as combinational logic. A flip-flop or latch is small compared to the combinational logic element (in sharp contrast to the situation in custom VLSI), so it

makes sense to add it to the combinational logic element. Using a separate cell for the memory element would simply take up routing resources. The memory element is connected to the output; whether it stores a given value is controlled by its clock and enable inputs.

In this paper, we propose incorporating (some) hardened multiplexers (MUXs) in the FPGA logic blocks as a means of increasing silicon area efficiency and logic density. The MUX-based logic blocks for the FPGAs have seen success in early commercial architectures, such as the Actel ACT-1/2/3 architectures, and efficient mapping to these structures has been studied in the early 1990s. However, their use in commercial chips has waned, perhaps partly due to the ease with which logic functions can be mapped into LUTs, simplifying the entire computer aided design (CAD) flow. Nevertheless, it is widely understood that the LUTs are inefficient at implementing MUXs, and that MUXs are frequently used in logic circuits. To underscore the inefficiency of LUTs implementing MUXs, consider that a six input LUT (6-LUT) is essentially a 64-to-1 MUX (to select 1 of 64 truth-table rows) and 64-SRAM configuration cells, yet it can only realize a 4-to-1 MUX (4 data+2 select=6 inputs). In this paper, we present a six-input LE based on a 4-to-1 MUX, MUX4, that can realize a subset of six-input Boolean logic functions, and a new hybrid complex logic block (CLB) that contains a mixture of MUX4s and 6-LUTs. The proposed MUX4s are small compared with a 6-LUT (15% of 6-LUT area), and can efficiently map all {2,3}-input functions and some {4,5,6}-input functions.

In addition, we explore factorability of Les the ability to split the LEs into multiple smaller elements in both LUTs and MUX4s to increase logic density. The ratio of LEs that should be LUTs versus MUX4s is also explored toward optimizing logic density for both nonfracturable and fracturable FPGA architectures. To facilitate the architecture exploration, we developed a CAD flow for mapping into the proposed hybrid CLBs, created using ABC and VPR, and describe technology mapping techniques that encourage the selection of logic functions that can be embedded into the MUX4 elements. The main contributions in this paper are as follows.

- 1) Two hybrid CLB architectures (nonfracturable and fracturable) that contain a mixture of MUX4 LEs and the traditional LUTs yielding up to 8% area savings.

2) Mapping techniques called Natural Mux and Mux Map targeted toward the hybrid CLB architecture that optimize for area, while preserving the original mapping depth.

3) A full post-place-and-route architecture evaluation with VTR7, and CHStone benchmarks facilitated by LegUp-HLS, the Verilog-to-Routing project showing impact on both area and delay.

Compared with the preliminary publication, we have performed transistor level modeling of the MUX4 LE, further studied the fracturable architectures, and unified the open source tool-flow from C through LegUp-HLS to the VTR flow. Sparse crossbars (versus full crossbars in the previous work) have also been included in our CLBs, increasing modeling accuracy. The new transistor-level modeling of the MUX4 also provides more accurate results as compared with the previous work. Results have also been expanded with the inclusion of timing results as well as larger architectural ratio sweeps.

II. LITERATURE REVIEW

Recent works have shown that the heterogeneous architectures and synthesis methods can have a significant impact on improving logic density and delay, narrowing the ASIC-FPGA gap. Works by Anderson and Wang with “gated” LUTs, then with asymmetric LUT LEs, show that the LUT elements present in commercial FPGAs provide unnecessary flexibility. Toward improved delay and area, the macrocell-based FPGA architectures have been proposed. These studies describe significant changes to the traditional FPGA architectures, whereas the changes proposed here build on architectures used in industry and academia. Similarly, and-inverter cones have been proposed as replacements for the LUTs, inspired by and-inverter graphs (AIGs).

Purnaprajna and Ienne explored the possibility of repurposing the existing MUXs contained within the Xilinx Logic Slices. Similar to this work, they use the ABC priority cut mapped as well as VPR for packing, place, and route. However, their work is primarily delay-based showing an average speed up of 16% using only ten of 19 VTR7 benchmarks.

In this article, we study the technology mapping problem for a novel field-programmable gate array

(FPGA) architecture that is based on k-input single-output programmable logic array- (PLA) like cells, or, k/m-macro cells. Each cell in this architecture can implement a single output function of up to k inputs and up to m product terms. We develop a very efficient technology mapping algorithm, km flow, for this new type of architecture. The experimental results show that our algorithm can achieve depth-optimality on almost all the test cases in a set of 16 Microelectronics Center of North Carolina (MCNC) benchmarks. Furthermore it is shown that on this set of benchmarks, with only a relatively small number of product terms ($m \leq k+3$), the k/m-macro cell-based FPGAs can achieve the same or similar mapping depth compared with the traditional k-input single-output lookup table- (k-LUT-) based FPGAs. We also investigate the total area and delay of k/m-macro cell-based FPGAs and compare them with those of the commonly used 4-LUT-based FPGAs. The experimental results show that k/m-macro cell-based FPGAs can outperform 4-LUT-based FPGAs in terms of both delay and area after placement and routing by VPR on this set of benchmarks. This paper presents experimental measurements of the differences between a 90-nm CMOS field programmable gate array (FPGA) and 90-nm CMOS standard-cell application specific integrated circuits (ASICs) in terms of logic density, circuit speed, and power consumption for core logic. We are motivated to make these measurements to enable system designers to make better informed choices between these two media and to give insight to FPGA makers on the deficiencies to attack and, thereby, improve FPGAs. We describe the methodology by which the measurements were obtained and show that, for circuits containing only look-up table-based logic and flip-flops, the ratio of silicon area required to implement them in FPGAs and ASICs is on average 35. Modern FPGAs also contain “hard” blocks such as multiplier/ accumulators and block memories. We find that these blocks reduce this average area gap significantly to as little as 18 for our benchmarks, and we estimate that extensive use of these hard blocks could potentially lower the gap to below five. The ratio of critical-path delay, from FPGA to ASIC, is roughly three to four with less influence from block memory and hard multipliers. The dynamic power consumption ratio is approximately 14 times and, with hard blocks, this gap generally becomes smaller.

In this paper the new architectural proposals are routinely generated in both academia and industry. For

FPGA's to continue to grow, it is important that these new architectural ideas are fairly and accurately evaluated, so that those worthy ideas can be included in future chips. Typically, this evaluation is done using experimentation. However, the use of experimentation is dangerous, since it requires making assumptions regarding the tools and architecture of the device in question. If these assumptions are not accurate, the conclusions from the experiments may not be meaningful. In this paper, we investigate the sensitivity of FPGA architectural conclusions to experimental variations. To make our study concrete, we evaluate the sensitivity of four previously published and well-known FPGA architectural results: lookup-table size, switch block topology, cluster size, and memory size. It is shown that these experiments are significantly affected by the assumptions, tools, and techniques used in the experiments.

III. PROPOSED ARCHITECTURES

A. MUX4: 4-TO-1 MULTIPLEXER LOGIC ELEMENT

The MUX4 LE shown in Fig. 3 consists of a 4-to-1 MUX with optional inversion on its inputs that allow the realization of any {2,3}-input function, some {4,5}-input functions, and one 6-input function a 4-to-1 MUX itself with optional inversion on the data inputs. A 4-to-1 MUX matches the input pin count of a 6-LUT, allowing for fair comparisons with respect to the connectivity and intra cluster routing. Any two-input Boolean function can be easily implemented in the MUX4: the two function inputs can be tied to the select lines and the truth table values (logic-0 or logic-1) can be routed to the data inputs accordingly. For three-input functions; consider that Shannon decomposition about one variable produces cofactors with at most two variables. A second decomposition of the cofactors about one of their two remaining variables produces cofactors with at most one variable. Such single-variable cofactors can be fed to the data inputs (the optional inversion may be needed), with the decomposition variables feeding the select inputs. Likewise, functions of more than four inputs can be implemented in the MUX4 as long as Shannon decomposition with respect to any two inputs produces cofactors with at most one input.

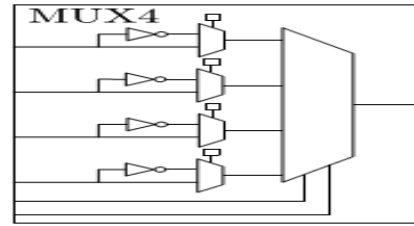

Fig.3. MUX4 LE depicting optional data input inversions

B. Logic Elements, Fracturability, and MUX4-Based Variants.

Two families of architectures were created:

- 1) Without fracturable LEs
- 2) With fracturable LEs.

In this paper, the fracturable LEs refer to an architectural element on which one or more logic functions can be optionally mapped. Nonfracturable LEs refer to an architectural element on which only one logic function is mapped. In the nonfracturable architectures, the MUX4 element shown in Fig. 3 is used together with nonfracturable 6-LUTs. This element shares the same number of inputs as a 6-LUT lending for fair comparison with respect to the input connectivity. For the fracturable architecture, we consider an eight-input LE, closely matched with the adaptive logic module in recent Altera Stratix FPGA families. For the MUX4 variant, Dual MUX4, we use two MUX4s within a single eight-input LE. In the configuration, shown in Fig. 4, the two MUX4s are wired to have dedicated select inputs and shared data inputs. This configuration allows this structure to map two independent (no shared inputs) three-input functions, while larger functions may be mapped dependent on the shared inputs between both functions. An architecture in which a 4-to-1 MUX (MUX4) is fractured into two smaller 2-to-1 MUXs was considered.

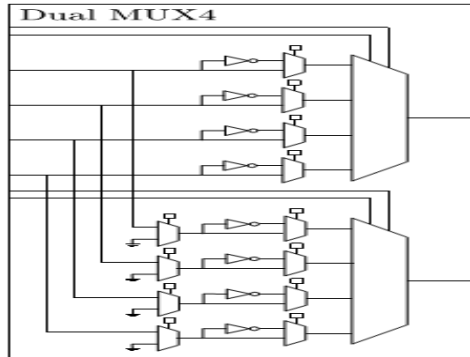

Fig.4. Dual MUX4 LE that utilizes dedicated select inputs and shared data Inputs

C. HYBRID COMPLEX LOGIC BLOCK

A variety of different architectures were considered the first being a nonfracturable architecture. In the nonfracturable architecture, the CLB has 40 inputs and ten basic LEs (BLEs), with each BLE having six inputs and one output. Fig.5 shows this nonfracturable CLB architecture with BLEs that contain an optional register. We vary the ratio of MUX4s to LUTs within the ten elements CLB from 1:9 to 5:5 MUX4s:6-LUTs. The MUX4 element is proposed to work in conjunction with 6-LUTs, creating a hybrid CLB with a mixture of 6-LUTs and MUX4s (or MUX4 variants).

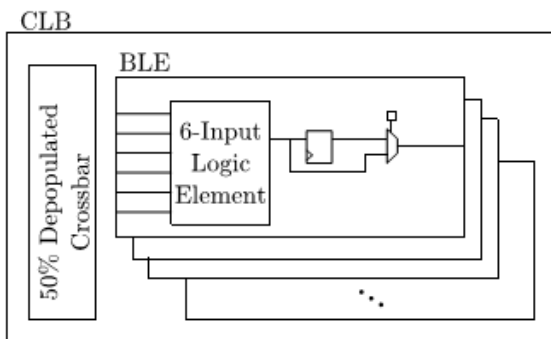

Fig. 5. Hybrid CLB with a 50% depopulated intra-CLB crossbar depicting BLE internals for nonfracturable (one optional register and one output) architecture.

Fig. 6 shows the organization of our CLB and internal BLEs. For fracturable architectures, the CLB has 80 inputs and ten BLEs, with each BLE having eight inputs and two outputs emulating an Altera Stratix Adaptive-LUT. The same sweep of MUX4 to LUT ratios was also performed. Fig. 4 shows the fracturable

architecture with eight inputs to each BLE that contains two optional registers. We evaluate fracturability of LEs versus nonfracturable LEs in the context of MUX4 elements since fracturable LUTs are common in commercial architectures. For example, Altera Adaptive 6-LUTs in Stratix IV and Xilinx Virtex 5 6-LUTs can be fractured into two smaller LUTs with some limitations on inputs.

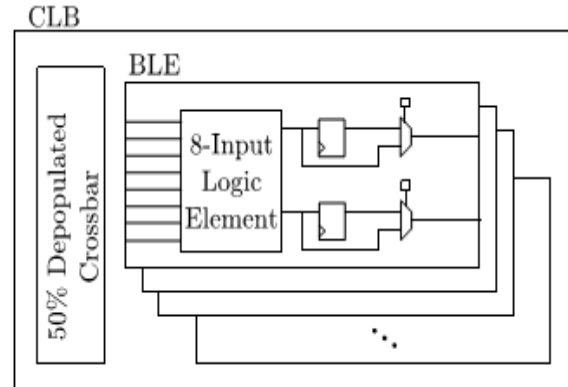

Fig.6. Hybrid CLB with a 50% depopulated intra-CLB crossbar depicting BLE internals for a fracturable (two optional registers and two outputs) architecture.

D. AREA MODELING

1) MUX4 Logic Element: Initial estimates of the MUX4 element showed that the MUX4 is ~10% the area of a 6-LUT overall. A 4-to-1 MUX can be realized with three 2-to-1 MUXs. Hence, the MUX4 element contains seven 2-to-1 MUXs, four SRAM cells, and four inverters in total (see Fig. 1). The optional inversion uses the four SRAM cells, whereas the rest of the LE configuration is performed through routing. In addition, the depth of the MUX tree is halved compared with the 6-LUT, which has six 2-to-1 MUXs on its longest paths. Conservatively, assuming constant pass transistor sizing and that the area of a 2-to-1 MUX and six transistor SRAM cell are roughly equivalent, the MUX4 element has (1/16)th the SRAM area and (1/8)th the MUX area of a 6-LUT.

These estimates were revised using transistor level modeling of the circuit blocks. Transistor-level optimization of the constituent circuit blocks of an FPGA requires an understanding of the optimal area-delay tradeoffs for each individual circuit block. This requires extracting a representative critical path, which is a path whose composition of blocks and topology will be similar

to the critical path of a specific design. Extracting the representative critical path allows us to judge to what extent each individual block is timing critical, which thus establishes an area-delay tradeoff goals for each block. This is in line with the transistor-level optimization tool developed previously. We use the results of prior work to establish the optimal area-delay tradeoff for 6-LUTs in conventional island-style FPGA architecture with typical architectural parameters. The resulting 6-LUT delay serves as a point of reference for optimization for the circuits considered in this paper: in the interest of maximizing area reduction while allowing performance to be maintained (ignoring the differences in cell counts between mapping to a conventional LUT and the LEs proposed in this paper), we attempt to match the delay of a 6-LUT while minimizing the area of each of the variants of the MUX4 circuits. Transistor level modeling and optimizations were based on a9 predictive 22-nm high performance process [21], while the area model presented in prior work [20] was used to estimate the area of various circuit structures. With this methodology, we determined an area-delay optimal 6-LUT has an area of 930 minimum-width transistors, and a worst-case delay of 261 ps. For the MUX4 cell and Dual MUX4 cell, a minimum area and minimum delay cell was created. The minimum area MUX4 cell has an area of 95 minimum width transistors and a delay of 204 ps; all transistors were minimum-width in this case, and as the minimum area solution for this circuit was able to meet (and improve upon) the worst-case delay target of a 6-LUT. Similarly, the Dual MUX4 cell has an area of 249 minimum-width transistors while meeting the worst-case delay requirement. However, we chose to use the minimum delay design for both the MUX4 and Dual MUX4 elements for the rest of the study as there is not a significant increase in area over the minimum area design.

2) FPGA Area Model:

Although determining the area of a MUX4 element relative to a 6-LUT is important, we need to also examine global FPGA area considering the number of CLB tiles, area overheads within the CLB and routing area per CLB. Throughout this paper, global FPGA area was estimated assuming that, per tile, 50% of the area is inter cluster and intra cluster routing, 30% of the area is used for LUTs,

and 20% for registers and other miscellaneous logic, following Anderson and Wang and a private communication. It is important to note that this 50%–30%–20% model is an estimate based on a traditional full FPGA design where-by the routing and internal CLB crossbars are optimized toward 6-LUTs. Production of an optimized FPGA utilizing our new MUX4 elements would surely change said model. However, optimizing the entire routing architecture toward our MUX4 variants, measuring the routing architecture, and closing the loop by creating a more accurate model is out of the scope of this work. Using this model, we can make some observations about the hybrid CLB architecture. The 30% that normally would account for ten 6-LUT LEs within the tile is now split between the smaller MUX4 elements and 6-LUTs.

IV. Technology Mapping Using ABC

ABC was used for technology mapping, with modifications that allow for MUX4-embeddable function identification and MUX2-embeddable function identification in the case of fracturable MUX4s and custom mapping. The internal data structure used within the ABC is an AIG, where the logic circuit is represented using 2-input AND gates with inverters. Priority Cuts mapping in ABC (invoked with the `if` command) was modified to perform our custom technology mapping. This mapper traverses the AIG from primary inputs to primary outputs finding intermediate mappings for internal nodes and finally the primary outputs, using a dynamic programming approach. The priority cuts mapper performs multiple passes on the AIG to find the best cut per node. For depth-oriented mapping, the mapper first prioritizes mapping depth then optimizes for area discarding cuts whose selection would increase the overall depth of the mapped network. Based on this standard mapper, two mapper variants were produced and evaluated. The first variant, Natural Mux, evaluates and identifies internal functions that are MUX4-embeddable, agnostic of the target architecture; i.e., this flow uses the default priority cuts mapping and performs a post processing step to identify MUX4-embeddable functions. From this mapping, we can evaluate what area savings are possible without any mapper changes. The second variant Mux Map, area-weights the MUX4-embeddable cuts relative to 6-LUT cuts, thereby establishing a preference for selection/creation of MUX4-embeddable solutions.

V. MODELING USING VPR

VPR was used to perform architectural evaluation. The standard ten 6-LUT CLB architecture in 40-nm included with the VPR distribution was used for baseline modeling. The hybrid CLBs shown in Figs. 3 and 4 were modeled using the XML-based VPR architectural language. The snippet from the architecture file for the physical block hardened MUX4 element, this code specifies a MUX4 as a six-input one-output black box to the VPR. In addition, since all MUX4s can also be mapped to the 6-LUTs, an additional mode was added to the 6-LUT physical block. The mode concept allows the VPR packer to pack LUTs into LUTs (as usual), but also enables MUX4s to be packed into the LUTs. The architectures with CLBs having MUX4: LUT ratios from 1:9 to 5:5 were created from the baseline 40-nm architectures with delays obtained through circuit simulations of the MUX4 variants. Importantly, we made minor modifications to the VPR packing algorithm itself, so that the MUX4 net list elements are preferred to be packed into the MUX4 Les in the architecture (while limiting packing MUX4 net list elements into LUTs). The modifications involved changing the attraction function during the CLB packing. One change was to ensure that the logic functions that were MUX4 embeddable were preferentially packed into a physical MUX4 element and not into an LUT. Another was to apply a negative weight on MUX4-embeddable functions when the current CLB's physical MUX4 elements are all occupied also preventing MUX4-embeddable functions from being placed into the LUTs. Without this, the MUX4 net list elements might needlessly consume LUTs, which should be reserved, where possible, for those net list elements that demand their flexibility. This becomes doubly important for fracturable architectures, since their packing problem is more complex. Without this modification, a significant CLB usage increase was observed across all benchmark sets.

EXTENSION

FIR FILTER: A FIR (Finite Impulse Response) filter is defined as a filter that has impulse response for a finite duration of time. Now the design of FIR filter is made by using equiripple method. The advantages of using FIR filters are their guaranteed stability and freedom from phase distortion.

FIR FILTER STRUCTURE

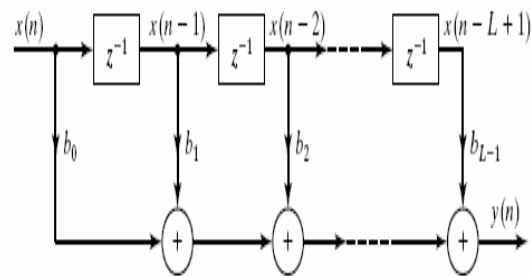

Figure 6 Direct Structure of an FIR Filter Above shows the structure of an Direct-form FIR filter and corresponding equation is given by

$$y(n) = \sum_{i=0}^{L-1} b_i x(n-i) \dots\dots\dots(1)$$

The input vectors in fig can be represented as $xT(n) = [x(n), x(n-1), \dots, x(n-L+1)] \dots(2)$ The coefficients in fig can be represented as

$$bT = [b_0, b_1, \dots, b_{L-1}] \dots\dots\dots(3)$$

Output of FIR filter is the sum of all the partial products between input and coefficients. Filters are signal conditioners. Each functions by accepting an input signal, blocking pre-specified frequency components, and passing the original signal minus those components to the output. For example, a typical phone line acts as a filter that limits frequencies to a range considerably smaller than the range of frequencies human beings can hear. That's why listening to CD- quality music over the phone is not as pleasing to the ear as listening to it directly.

VI. RESULTS

SIMULATION

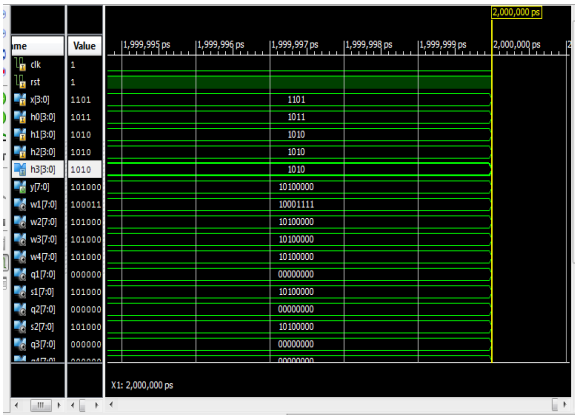

RTL SCHEMATIC

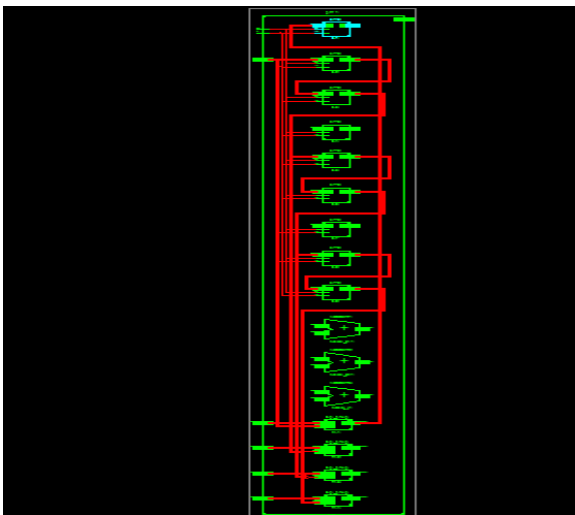

TECHNOLOGY

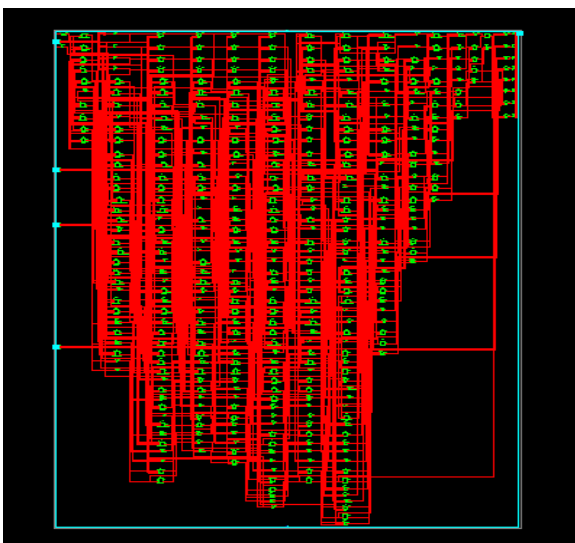

DESIGN SUMMARY

Device Utilization Summary (estimated values)			
Logic Utilization	Used	Available	Utilization
Number of Slices	99	4656	2%
Number of Slice Flip Flops	48	9312	0%
Number of 4 input LUTs	176	9312	1%
Number of bonded IOBs	30	232	12%
Number of GCLs	1	24	4%

TIME DELAY

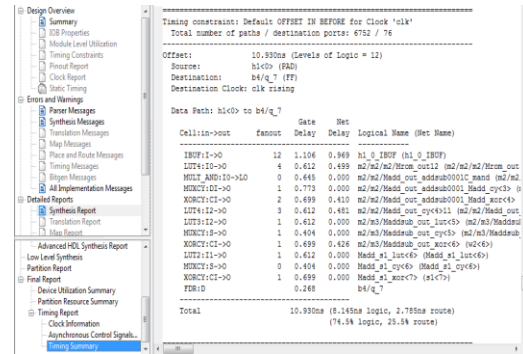

VII. CONCLUSION

In this paper we proposed a new hybrid CLB architecture containing MUX4 hard MUX elements and shown techniques for efficiently mapping to these architectures. We also provided analysis of the benchmark suites post mapping, discussing the distribution of functions within each benchmark suite. The area reductions for nonfracturable architectures, is 8% and MUX4:LUT ratio is 4:6 and in the case of fracturable architecture the area reductions are 2%. The CHStone benchmarks being high-level synthesized with LegUp-HLS also showed marginally better performance and this could be due to the way LegUp performs HLS on the CHStone benchmarks themselves. Overall, the addition of MUX4s to FPGA architectures minimally impact FMax and show potential for improving logic-density in nonfracturable architectures and modest potential for improving logic density in fracturable architecture.

REFERENCES

[1] J. Rose et al., "The VTR project: Architecture and CAD for FPGAs from verilog to routing," in Proc. ACM/SIGDA FPGA, 2012, pp. 77–86.

[2] Y. Hara, H. Tomiyama, S. Honda, and H. Takada, "Proposal and quantitative analysis of the CHStone

benchmark program suite for practical C-based high-level synthesis,” *J. Inf. Process.*, vol. 17, pp. 242–254, Oct. 2009.

[3] A. Canis et al., “LegUp: High-level synthesis for FPGA-based processor/accelerator systems,” in *Proc. ACM/SIGDA FPGA*, 2011, pp. 33–36.

[4] E. Ahmed and J. Rose, “The effect of LUT and cluster size on deep submicron FPGA performance and density,” *IEEE Trans. Very Large Scale Integer. (VLSI)*, vol. 12, no. 3, pp. 288–298, Mar. 2004.

[5] J. Rose, R. Francis, D. Lewis, and P. Chow, “Architecture of field programmable gate arrays: The effect of logic block functionality on area efficiency,” *IEEE J. Solid-State Circuits*, vol. 25, no. 5, pp. 1217–1225, Oct. 1990.

[6] H. Parandeh-Afshar, H. Benbihi, D. Novo, and P. Jenne, “Rethinking FPGAs: Elude the flexibility excess of LUTs with and-inverter cones,” in *Proc. ACM/SIGDA FPGA*, 2012, pp. 119–128.

[7] J. Anderson and Q. Wang, “Improving logic density through synthesis inspired architecture,” in *Proc. IEEE FPL*, Aug./Sep. 2009, pp. 105–111.

[8] J. Anderson and Q. Wang, “Area-efficient FPGA logic elements: Architecture and synthesis,” in *Proc. ASP DAC*, 2011, pp. 369–375.

[9] J. Cong, H. Huang, and X. Yuan, “Technology mapping and architecture evaluation for k/m-macrocell-based FPGAs,” *ACM Trans. Design Autom. Electron. Syst.*, vol. 10, no. 1, pp. 3–23, Jan. 2005