

# Fuzzy Control Stand-Alone Micro Grid System with Battery Energy Storage System

M.Vennela & B.Gopal

\*PG Scholar, Dept of EEE, KITS Engineering College, Ponnekal; Khammam (Dt), Telangana, India.

\*\*Assistant Professor, Dept of EEE, KITS Engineering College, Ponnekal; Khammam (Dt), Telangana, India.

## ABSTRACT-

*Battery Energy Storage System (BESS) is used for primary frequency regulation. As developments in batteries progress, advancement in applications of BESS including the implementation in high power penetration is expected. Load shedding is one of frequency control methods during stand-alone operation, and the performance of frequency control improves in combination with BESS. However, without optimal size of BESS, it can cause the oscillations to the system. Thus, this article proposes the feasibility of using optimal BESS with load shedding scheme when the micro grid is disconnected from a main source. In the developing of smart grid, many new technologies and components such as energy storage and micro grid are playing more and more role for making the power system more reliable and efficient. A grid-connected micro grid consists of local controllers, local consumers, renewable energy generators and storage facilities will become an important part of future smart grid. The State of Charge (SOC) of battery bank is in an insufficient state, BESS is not possible to act as a continuous supplier. To charge SOC of the battery bank, the control methods of two charging modes are proposed and stability of control. BESS requires the stable and robust control methods whether performs either Constant Voltage Constant Frequency (CVCF) or grid-connected mode. In the controller point of view, Fuzzy control is widely used to supply stable voltage and current.*

**Key words-** Battery Energy Storage Systems (BESS), Microgrid, Fuzzy Logic Controller

## INTRODUCTION

Micro grids are becoming popular in distribution

systems because they can improve the power quality and reliability of power supplies and reduce the environmental impact. Micro grid operation can be classified into two modes: grid connected and islanded modes. In general, micro grids are comprised of distributed energy resources (DERs) including renewable energy sources, distributed energy storage systems (ESSs), and local loads [1–3]. However, the use of renewable energy sources such as wind and solar power in micro grids causes power flow variations owing to uncertainties in their power outputs. These variations should be reduced to meet power-quality requirements [4, 5]. This study focuses on handling the problems that are introduced by wind power. To compensate for fluctuations in wind power, various ESSs have been implemented in micro grids. Short-term ESSs such as superconducting magnetic energy storage (SMES) systems [6], electrical double-layer capacitors (EDLCs) [7], and flywheel energy storage systems (FESSs) as well as long-term ESSs such as battery energy storage systems (BESSs) [8-9] are applied to micro grid control. ESSs can also be used to control the power flow at point of common coupling in the grid-connected mode as well as to regulate the frequency and voltage of a micro grid in the

islanded mode. Among these ESSs, BESSs have been implemented widely owing to their versatility, high energy density, and efficiency. Moreover, their cost has decreased whereas their performance and lifetime has increased.

In practice, BESSs with high performance such as smooth and fast dynamic response during charging and discharging are required for micro grid control. This performance depends on the control performance of the power electronic converter. Proportional-integral (PI) control is a practical and popular control technique for BESS control systems. However, PI control might show unsatisfactory results for nonlinear and discontinuous systems [10]. When properly applied, these new, distributed generation units (DG) offer significant benefit to the grid and to end users. However, merging DGs into the traditional grid is not without technological challenges.

The traditional electrical grid was not designed for power generation sources distributed near the ends of the T&D grid. The successful integration of DG power sources requires the single-direction grid architecture of the past transition to a smarter and more agile bi-directional grid [11]. As DGs continue to gain traction in the electrical market, new thinking and new strategies around power generation, distribution and consumption will continue to emerge. On the increasingly common tactics for merging DGs into the larger electrical grid is a new twist on an old electrical architecture known as the micro grid. Micro grids are areas of the grid that can operate as part of the larger micro grid or operate autonomously as a standalone system. The micro grids systems help facilitate the integration of DG assets into the larger electrical grid. Further when properly implemented, micro grids can unlock a wide array of stacked values for grid operators and

electrical consumers [12- 13]. This paper focus on a fuzzy logic based coordinated control scheme of a BESS and displaceable DG units is developed for microgrid.

## I. PROPOSED TWO CHARGING MODES

### a) Configuration of a stand-alone microgrid

Figure1 shows configuration of a stand- alone microgrid that consist of 50kW BESS, 50kW diesel generator and controllable loads. In BESS, DC link is connected to 115kWh Lead-Acid battery bank with 48 200AH/12V batteries and LCL filter is adopted to attenuate switching frequency ripples of current. The grid inductances  $L_2$  include the leakage inductance of isolation transformer and synchronous inductance of diesel generator.

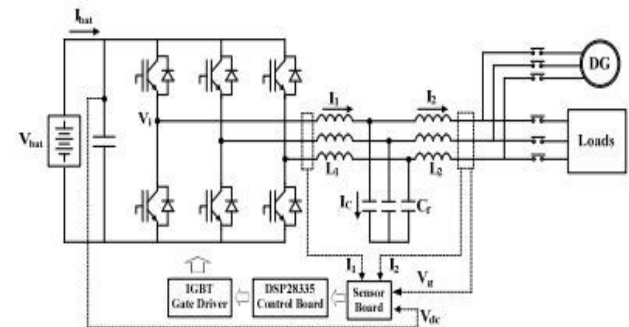

Fig.1 The configuration of a stand-alone microgrid

### b) The operation modes of the stand-alone microgrid

Figure 2 shows the operation mode of the stand-alone microgrid, which are divided into four modes. In normal mode, BESS performs CVCF and DG stops. In charge mode, BESS is controlled by CVCF and DG performs active power control. It corresponds to charging mode I when charging from DG. On the contrary, in manual mode, DG performs CVCF control and BESS is operated by CC-CV control. It corresponds to charging mode II. When SOC of battery bank is insufficient, BESS is normally charged through DG in either

charging mode I or charging mode II depending on operating modes.

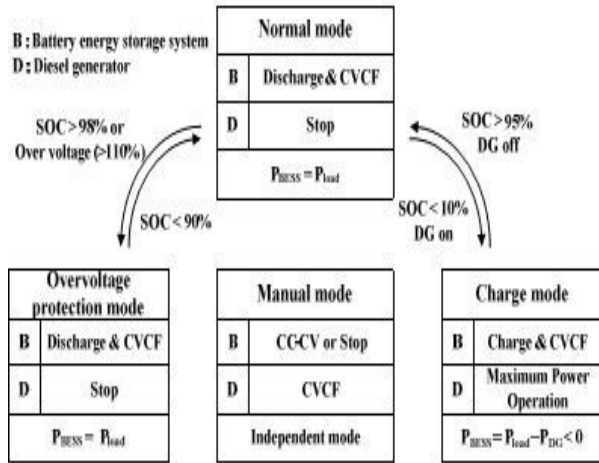

Fig.2: The operation mode of the stand-alone microgrid

**c) Control in two charging modes**

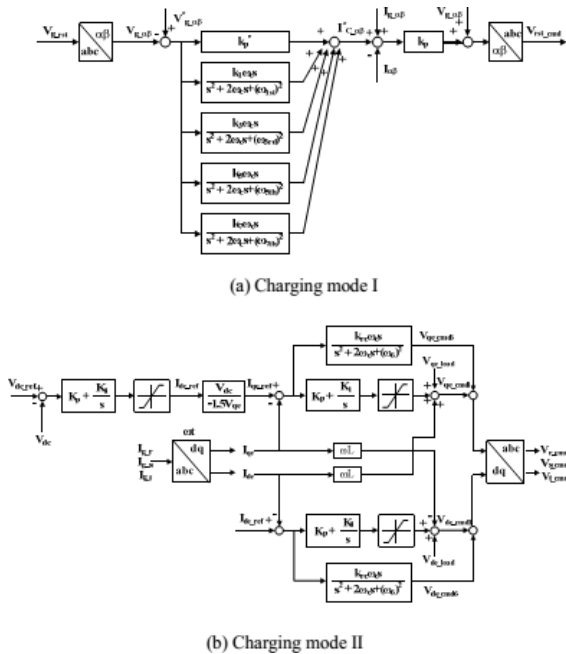

Figure3: Control of two charging methods Fig 3 shows control methods of the two charging modes in the stand-alone microgrid.

Figure 3.3 (a) shows control in charging mode I that includes an outer PR voltage feedback loop

for line to line voltage and an inner P current feedback loop. In the outer voltage loop, PR controller regulates fundamental

positive/negative sequence voltage as well as selective harmonics compensation for three, fifth, seventh. Damping of the resonance of LCL filter is possible to by controlling capacitor current which are calculated by the difference of grid and inverter currents. Figure

3.3 (b) shows control in charging mode II where the outer loop regulates dc link voltage to maintain battery bank voltage and the inner current loop maintains unity power factor. Current control is based on PI controller in the synchronous reference frame and R controller is adopted to compensate lower harmonics. The control methods must guarantee the performance and the stability of the whole system.

**II. ANALYSIS IN THE STABILITY OF TWO CHARGING MODES**

**a) Stability of the charging mode I**

In the stand-alone microgrid, the way to charge battery bank of BESS is to connection with DG either charging mode I or charging mode II. Figure 4 shows continuous time modeling of voltage and current control loops for charging mode I that includes an outer PR voltage feedback loop for line to line voltage and an inner P current feedback loop. (1) is to the transfer function of PR controller for fundamental voltage control. An inner current feedback loop controls the filter capacitor current. It means that active damping of multi- loop methods is applied to attenuate resonance influence of LCL filters as well as improve stability of voltage control. In charging mode I, the role and the stability of the voltage control are very important since BESS operates CVCF control as main source. In this paper, system



$$(4) \quad G_{LCL}(s) = \frac{I_2(s)}{V_i(s)} = \frac{1}{L_1 s} \frac{z_{LC}^2}{(s^2 + \omega_{res}^2)}$$

Current control with LCL filters can introduce a resonance problem that makes the control system unstable considerably. In charging mode II, passive damping method that passive resistors are connected to filter capacitors in series is adopted to attenuate resonance influence. Therefore, Transfer function of (4) is replaced with (5). The small passive resistors values as  $0.3\Omega$  is selected in order to minimize the losses caused by passive damping resistors and that is small enough to ignore. For discrete modeling, (5) is transformed by ZOH method.

$$(5) \quad G_{LCL}(s) = \frac{I_2(s)}{V_i(s)} = \frac{1}{L_1 s} \frac{s \frac{R_d}{L_2} + z_{LC}^2}{(s^2 + sR_d C_f \omega_{res}^2 + \omega_{res}^2)}$$

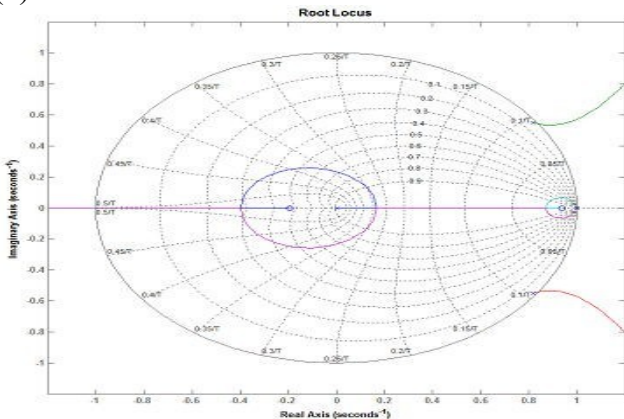

Fig.7: The stability of charging mode II using root locus in z-domain

### III. FUZZY CONTROLLER

Figure 8 shows the internal structure of the control circuit. The control scheme consists of Fuzzy controller, limiter, and three phase sine wave generator for reference current generation and generation of switching signals. The peak value of reference currents is estimated by regulating the DC link voltage. The actual

capacitor voltage is compared with a set reference value. The error signal is then processed through a Fuzzy controller, which contributes to zero steady error in tracking the reference current signal. A fuzzy controller converts a linguistic control strategy into an automatic control strategy, and fuzzy rules are constructed by expert experience or knowledge database. Firstly, input voltage  $V_{dc}$  and the input reference voltage  $V_{dc-ref}$  have been placed of the angular velocity to be the input variables of the fuzzy logic controller. Then the output variable of the fuzzy logic controller is presented by the control Current  $I_{max}$ . To convert these numerical variables into linguistic variables, the following seven fuzzy levels or sets are chosen as: NB (negative big), NM (negative medium), NS (negative small), ZE (zero), PS (positive small), PM (positive medium), and PB (positive big) as shown in Figure 9.

The fuzzy controller is characterized as follows:

- 1) Seven fuzzy sets for each input and output;
- 2) Fuzzification using continuous universe of discourse;
- 3) Implication using Mamdani's 'min' operator;
- 4) De-fuzzification using the 'centroid' method.

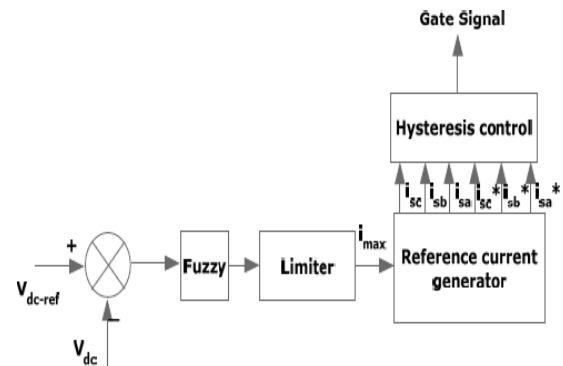

Fig.8. Conventional fuzzy controller

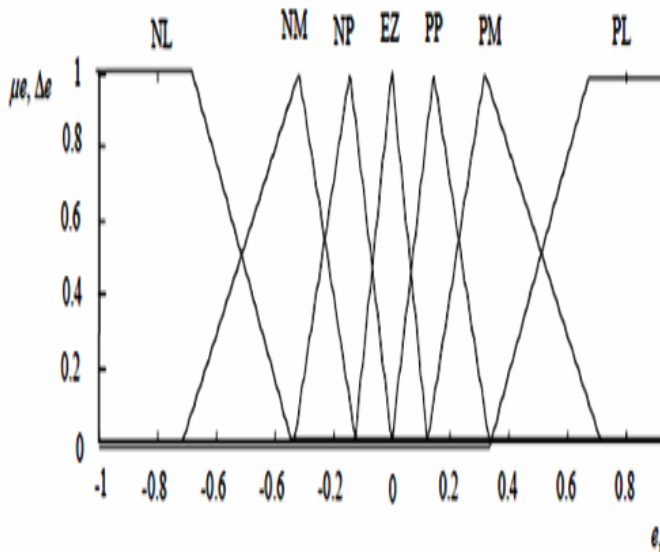

Fig.9. (a) Input Vdc normalized membership function; (b) Input Vdc-ref Normalized Membership Function; (c) Output Imax Normalized Membership Function.

**Fuzzification:** the process of converting a numerical variable (real number) convert to a linguistic variable (fuzzy number) is called fuzzification.

**De-fuzzification:** the rules of FLC generate required output in a linguistic variable (Fuzzy Number), according to real world requirements, linguistic variables have to be transformed to crisp output (Real number).

**Database:** the Database stores the definition of the membership Function required by fuzzifier and defuzzifier.

**Rule Base:** the elements of this rule base table are determined based on the theory that in the transient state, large errors need coarse control, which requires coarse in-put/output variables; in the steady state, small errors need fine control, which requires fine input/output variables. Based on this the elements of the rule table are obtained as shown in Table 1, with 'Vdc' and 'Vdc-ref' as inputs.

Table 1: Rules for Fuzzy System

$e$ \ $\Delta e$	NL	NM	NS	EZ	PS	PM	PL
NL	NL	NL	NL	NL	NM	NS	EZ
NM	NL	NL	NL	NM	NS	EZ	PS
NS	NL	NL	NM	NS	EZ	PS	PM
EZ	NL	NM	NS	EZ	PS	PM	PL
PS	NM	NS	EZ	PS	PM	PL	PL
PM	NS	EZ	PS	PM	PL	PL	PL
PL	NL	NM	NS	EZ	PS	PM	PL

#### IV. MATLAB/ SIMULATION RESULTS

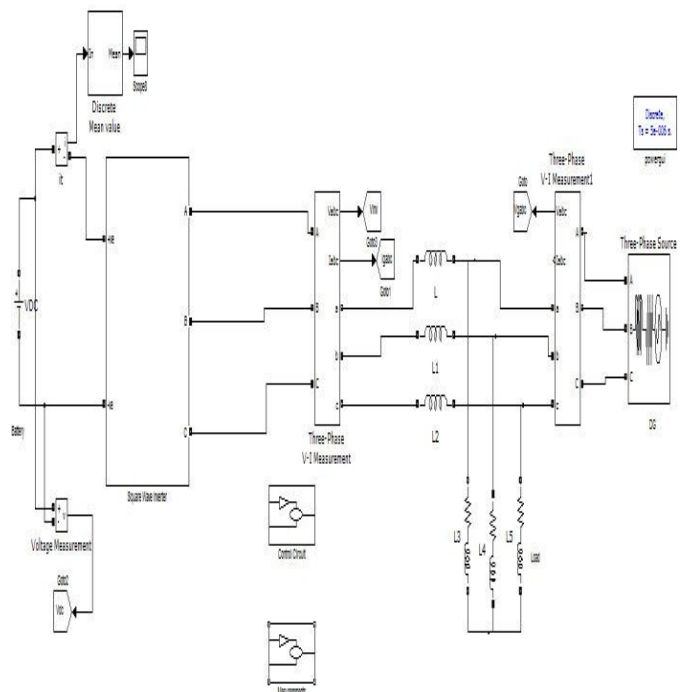
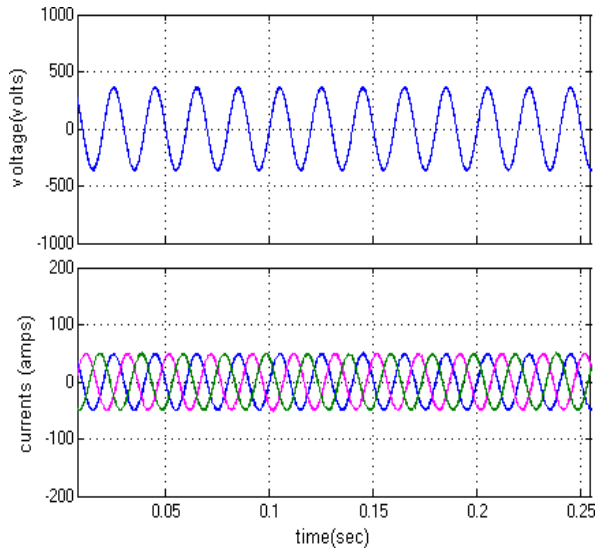
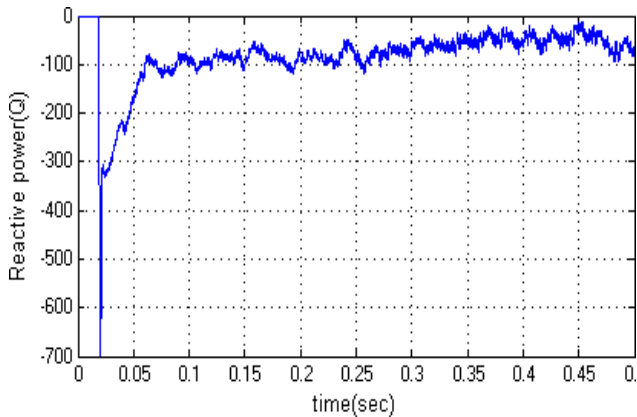
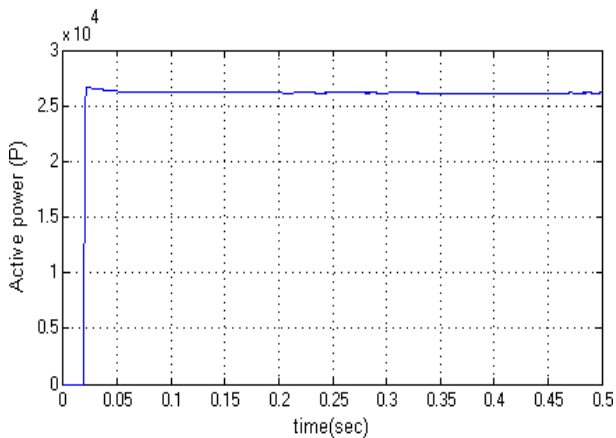

Fig.10 MATLAB and Simulink circuit for Proposed BESS



(a) Voltage and currents in 40kW



(b) BESS 40kW charging

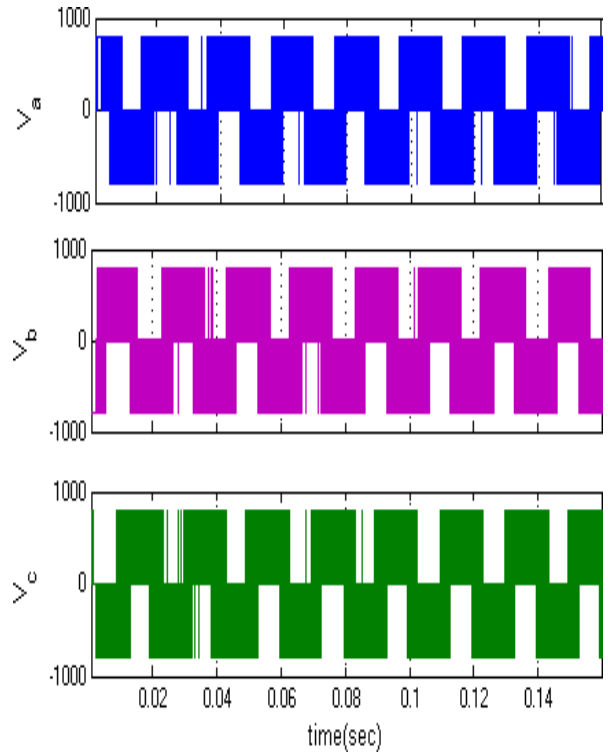

(c) Inverter Voltages

Fig.11 Simulation results for (a) voltage and currents (b) BESS charging (c) Inverter voltages

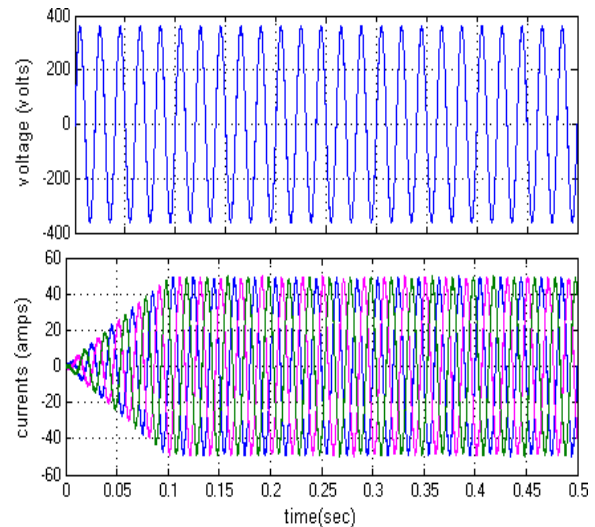

(a) BESS 40kW charging





balance between the technical performance and the physical constraint.

## REFERENCES

- [1] José G. de Matos, Member, IEEE, Felipe S. F. e Silva, Student Member, IEEE, and Luiz A. de S. Ribeiro, Member, IEEE” Power Control in AC Isolated Micro grids With Renewable Energy Sources and Energy Storage Systems” IEEE Transactions On Industrial Electronics, Vol. 62, No. 6, June 2015.
- [2] L. A. de S. Ribeiro, O. R. Saavedra, S. L. de Lima, and J. G. de Matos, “Isolated micro-grid with renewable hybrid generation: The case of Lençóis island,” IEEE Trans. Sustain. Energy, vol. 2, no. 1, pp. 1–11, Jan. 2011.
- [3] L. A. de S. Ribeiro, O. R. Saavedra, S. L. de Lima, and J. G. de Matos, “Making isolated renewable energy systems more reliable,” Renew. Energy, vol. 45, pp. 221–231, Sep. 2012.
- [4] J. G. de Matos, L. A. de S. Ribeiro, and E. C. Gomes, “Power control in ac autonomous and isolated micro grids with renewable energy sources and energy storage systems,” in Proc. IEEE IECON, 2013, pp. 1827–1832.
- [5] N. Mendis, K. M. Muttaqi, S. Pereira, and M. N. Uddin, “A novel control strategy for stand-alone operation of a wind dominated RAPS system,” in Proc. IEEE IAS Annu. Meeting, 2011, pp. 1–8.
- [6] J. Chen, J. Cheng, C. Gong, and X. Deng, “Energy management and power control for a stand-alone wind energy conversion system,” in Proc. IEEE IECON, 2012, pp. 989–994.
- [7] M. J. Erickson and R. H. Lasseter, “Integration of battery storage element in a CERTS micro grid,” in Proc. IEEE ECCE, 2010, pp. 2570–2577.
- [8] J. Rocabert, J. A. Luna, F. Blaabjerg, and P. Rodríguez, “Control of power converters in ac micro grids,” IEEE Trans. Power Electron., vol. 27, no. 11, pp. 4734–4749, Nov. 2012.
- [9] C. Jin, P. Wang, J. Xiao, Y. Tang, and F. H. Choo, “Implementation of hierarchical control in dc micro grids,” IEEE Trans. Ind. Electron., vol. 61, no. 8, pp. 4032–4042, Feb. 2014.
- [10] X. Lu, K. Sun, J. M. Guerrero, J. C. Vasquez, and L. Huang, “State-of-charge balance using adaptive droop control for distributed energy storage systems in dc micro grid applications,” IEEE Trans. Ind. Electron., vol. 61, no. 6, pp. 2804–2815, Jun. 2014.
- [11] M. A. Abusara, J. M. Guerrero, and S. M. Sharkh, “Lineinteractive UPS for micro grids,” IEEE Trans. Ind. Electron., vol. 61, no. 3, pp. 1292–1300, Mar. 2014.
- [12] J. M. Guerrero, P. X. Loh, T.-L. Lee, and M. Chandorkar, “Advanced control architectures for intelligent micro grids– Part II: Power quality, energy storage, ac/dc micro grids,” IEEE Trans. Ind. Electron., vol. 60, no. 4, pp. 1263–1270, Apr. 2013.
- [13] Z. Chen, J. M. Guerrero, and F. Blaabjerg, “A review of the state of art of power electronics for wind turbines,” IEEE Trans. Power Electron., vol. 24, no. 8, pp. 1859–1875, Aug. 2009.