

Self Heterodyne in MIMO OFDM system on Relay path Analysis

B.JAYANDER , K.SATYAVATHI & DR.M.NARSING YADAV

PG Scholar, Assistant Professor, Head of the Department & Professor , Department Of Electronics & Communication Engineering, Malla Reddy Institute Of Engineering & Technology Hyderabad, Telangana, India, jayander2490@gmail.com , satyanarayana.ah.@gmail.com , Hodece@mriet.ac.in

ABSTRACT:-

Multiple input, multiple output-orthogonal frequency division multiplexing (MIMO-OFDM) is the dominant air interface for broadband wireless communications (4G & 5G). Heterodyning, also called frequency conversion, is used widely in communications engineering to generate new frequencies and move information from one frequency channel to another. In Our Project, we proposed a multiple-input multiple-output (MIMO) self-het OFDM with the adaption of smart carrier position (SCP) technique. At the transmitter, a space-time block code (STBC) is used to produce the coded information symbols to be transmitted on each antenna over the self-het OFDM subcarriers. At the receiver, a simple non-linear detection is adopted at each receiver communication side. The achievable diversity order of such setting is analyzed, and it is found that with the adaptation of SCP technique, the diversity loss in comparison to the conventional coherent MIMO-OFDM can be compensated. In MIMO System we used the Alamouti code and SCP technique with different modulation process.

Keywords: - MIMO-OFDM, Self-Heterodyne, 16-QAM, 64-QAM, 128-QAM and 256 QAM, Alamouti Code

1. INTRODUCTION

OFDM is becoming the chosen modulation technique for wireless communication. With the help of OFDM, sufficient robustness can be achieved to provide large data rates to radio channel impairments. In an OFDM scheme, a large number of orthogonal, overlapping narrow band sub-channels or sub-carriers transmitted in parallel by dividing the available transmission bandwidth. Compact spectral utilization with utmost efficiency is achieved with the help of minimally separated sub-carriers. Main attraction of OFDM lies with how the system handles the multipath

interference at the receiver end. Multiple inputs and multiple outputs is a method for multiplying the

capacity of a radio link using multiple transmit and receive antennas to exploit multipath propagation. MIMO has become an essential element of wireless Communication standards including IEEE802.11n (Wi-Fi), HSPA+ (3G), Wi-MAX (4G), and Long Term Evolution (4G). More recently, MIMO has been applied to power-line communication for 3-wire installations as part of ITU standard and Home Plug AV2 specification. MIMO-OFDM is the foundation for most advanced wireless local area network (Wireless LAN) and mobile broadband network standards because it achieves the greatest spectral efficiency and, therefore, delivers the highest capacity and data throughput. Greg Raleigh invented MIMO in 1996 when he showed that different data streams could be transmitted at the same time on the same frequency by taking advantage of the fact that signals transmitted through space bounce off objects (such as the ground) and take multiple paths to the receiver. That is, by using multiple antennas and pre-coding the data, different data streams could be sent over different paths. Raleigh suggested and later proved that the processing required by MIMO at higher speeds would be most manageable using OFDM modulation, because OFDM converts a high-speed data channel into a number of parallel, lower-speed channels.

2. EXISTING METHOD ANALYSIS

Self-heterodyne OFDM (self-het OFDM) is a promising physical layer technique for milli meter-wave and terahertz RF communication due to its simple RF frontend and complete immunity against frequency-offset and phase noise. It shows various techniques as STBC under Alamouti code sequence

of Self Heterodyne the performance characteristics based on BER versus SNR. It consists of Alamouti code and Golden code with SCP technique on no phase noise with using Alamouti code sequence MIMO self-het OFDM and super heterodynes OFDM. The main drawback of these smart antennas is that they are far more complicated than traditional antennas [MIMO]. This means that fault or problems may be harder to diagnose and more likely to occur. The location of smart antennas [MIMO] needs to be considered for optimal operation. Due to the directional beam that ‘swings’ from a smart antenna locations which are optimal for a traditional antenna is not for a smart antenna [MIMO].

3. PROBLEM DEFINITION

In 2X2 MIMO Self-Het OFDM system as an implementation of low complexity stable oscillators is technically difficult. So the performance of self-het OFDM channel undergoes on deep fading. Using Alamouti code sequence on 2X2 MIMO system based self-het OFDM with reduced BER using without diversity loss and side information loss with less amount of fading.

4. PROPOSED SYSTEM

One of the core ideas behind MIMO wireless systems space-time signal processing in which time (the natural dimension of digital communication data) is complemented with the spatial dimension inherent in the use of multiple spatially distributed antennas, i.e. the use of multiple antennas located at different points.

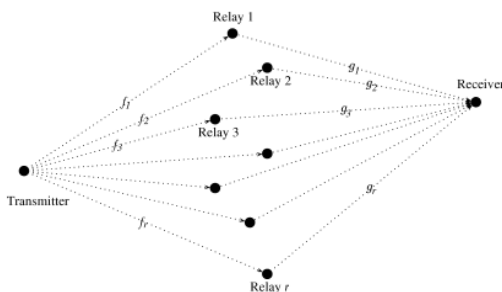

Fig: MIMO-Relay Path Process

Accordingly MIMO wireless systems can be viewed as a logical extension to the smart antennas that have been used for many years to improve wireless. It is found between a transmitter and a receiver; the signal can take many paths. Additionally by moving the antennas even a small distance the paths used will change. The variety of paths available occurs as a result of the number of objects that appear to the side or even in the direct path between the transmitter and receiver. Previously these multiple paths only served to introduce interference. By using MIMO, these additional paths can be used to advantage. They can be used to provide additional robustness to the radio link by improving the signal to noise ratio, or by increasing the link data capacity.

Cooperative Communication on Relay Process:-

In multi-user communication environment, cooperative communication technique enables the neighbouring mobile users with single antenna to share their antennas in some way for cooperative transmission, which is similar to a distributed virtual multi-antenna transmission environment and combines the advantages of both diversity technology and relay transmission technology. As a result, the spatial diversity gains can be achieved and the system’s transmission performance can be improved in a cooperative communication system without adding any antennas.

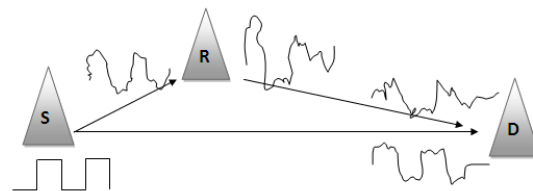

Fig: Relay Path Process

2X2 MIMO self-het OFDM and super heterodyne OFDM using Alamouti code sequence with various bit data values as 16/64/128/256 QAM.. Each pair of

transmit-receive antennas provides a signal path from transmitter to receiver. By sending the same information through different paths, multiple independently-faded replicas of the data symbol can be obtained at the receiver end. Hence, more reliable reception is achieved. A diversity gain d implies that in the high SNR region, my P_e decays at a rate of $1/\text{SNR}$ as opposed to $1/\text{SNR}$ for a SISO system.

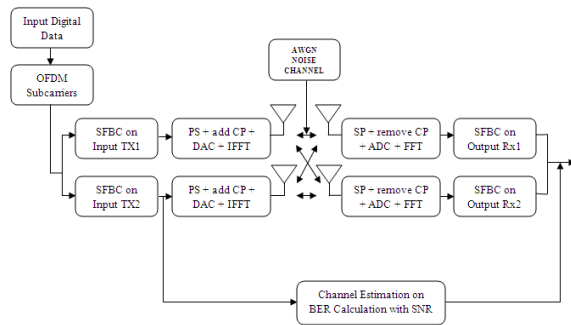

Fig: 1 MIMO-OFDM self heterodyne using Alamouti Code Sequence method

The maximal diversity gain d_{max} is the total number of independent signal paths that exist between the transmitter and receiver. For an (MR, MT) system, the total number of signal paths is $MRMT$ $1 \leq d \leq d_{max} = MRMT$. The higher my diversity gain, the lower my P_e . H is the MIMO channel frequency responses matrix, N_t is the number of transmit antennas, N_r is the number of receive antennas, f_c is RF carrier frequency, Δf is OFDM subcarrier spacing, N_s is the number of OFDM subcarriers used to encode information at each transmit antenna, N_g is the number of subcarriers omitted in each self-het OFDM transmitter, N ($N = N_g + N_s$) is the size of IFFT/FFT, B_g is the frequency gap between the RF carrier and the first OFDM subcarrier, and B_s is the useful OFDM subcarrier bandwidth. MIMO systems can be defined as: Given an arbitrary wireless communication system, we consider a link in which the transmitting ends as well as the receiving end is equipped with multiple antenna elements. The idea behind MIMO is that the signals on the transmit (TX) antennas at one end and the receive (RX) antennas at the other end are “combined” in such a way that the quality (bit-error rate or BER) or the data rate (bits/sec) of the communication for each MIMO user will be improved. Such an advantage can be used to increase both the network’s quality of service and the operator’s revenues significantly.

SPACE-TIME BLOCK CODES

Space-time block codes (STBC) are orthogonal and can achieve full transmit diversity specified by the number of transmit antennas. The concept of space-time coding has arisen from diversity techniques using smart antennas. By using data coding and signal processing at both sides of transmitter and receiver, space-time coding now is more effective than traditional diversity techniques. The data are constructed as a matrix which has its columns equal to the number of the transmit antennas and its rows equal to the number of the time slots required to transmit the data. At the receiver side, the signals received are first combined and then sent to the maximum likelihood detector where the decision rules are applied. Space-time block codes were designed to achieve the maximum diversity order for the given number of transmit and receive antennas subject to the constraint of having a simple linear decoding algorithm. This has made space-time block codes a very popular and most widely used scheme.

Alamouti scheme is the basis of the Space Time Coding technique. The mathematical explanation of the scheme with two transmitting and one receiving antennas is also explained here. In this work, a two-branch transmit diversity scheme is implemented. Using two transmit antennas and one receive antenna, the scheme provides the same diversity order as maximal ratio receiver combining (MRRC) with one transmit antenna and two receive antennas. The scheme may easily be generalized to two transmit antennas and M receive antennas to provide a diversity order of $2M$.

At the transmitter side, a block of two symbols is taken from the source data and sent to the modulator. After that, Alamouti space-time encoder takes the two modulated symbols, in this case called s_1 and s_2 creates encoding matrix S where the symbols s_1 and s_2 are mapped to two transmit antennas in two transmit time slots. The encoding matrix is given by the equation 1.

$$X = \begin{bmatrix} S_1 & -S_2^* \\ S_2 & S_1^* \end{bmatrix} \dots \dots \dots \text{eqn (1)}$$

Alamouti space time encoder: Here the information to be transmitted is modulated and fed to the space time encoder. The space time encoder

consists of two transmit antennas as part of the multiple output technology. So here the information is transmitted through two separate antennas. Each transmitting and receiving antenna pair has a channel, represented by different channel coefficients. These channel coefficients play a major role in the design of the system. As the number of antennas increases at both the ends of the channels, the complexity of the system also increases.

5. RESULTS & DISCUSSION

The 2X2 MIMO OFDM system using Alamouti code and SCP technique (no phase noise) with the various bit data values such as 16QAM, 64QAM, 128QAM, 256QAM. Simulation is carried out for MIMO OFDM system with Self Heterodyne on SCP technique.

	16QAM	64QAM	126QAM	256QAM
Self_Het_P=2	0.0892	0.0913	0.091	0.0919
Self_Het_P=3	0.06	0.061	0.0604	0.0615
Self_Het_P=4	0.0149	0.0153	0.0151	0.0154

Comparison between BER versus SNR with 2X2 MIMO Self-Het Pilot values P=2, 3&4 for 16, 64, 126&256 bits.

The above table represents the comparison between BER versus SNR with 2X2 MIMO self-het pilot values P=2, 3&4 for 16, 64,128 & 256 QAM's. The overall comparison between various bits with the input data chosen as a random pilot values P=2, 3&4 provides the BER versus SNR ranges. From the values obtained it is found that the BER Vs SNR is 16QAM which is the lowest signifying high performance with no phase noise. The other bit values are compared to 16QAM which is highest signifying low performance with no phase noise. The study and comparisons are based on simulation done using MATLAB. The BER performance as a function of SNR is examined for various bits levels and the results are plotted as reported in below the figures.

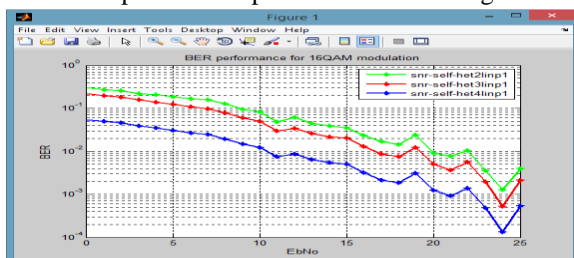

The 2X2 MIMO self-het OFDM for 16bit QAM is shown in fig 2.1. The input data chosen as random pilot values as 2, 3&4 were mapped into 16QAM constellation. MIMO OFDM multicarrier transmission was carried out using MATLAB application..

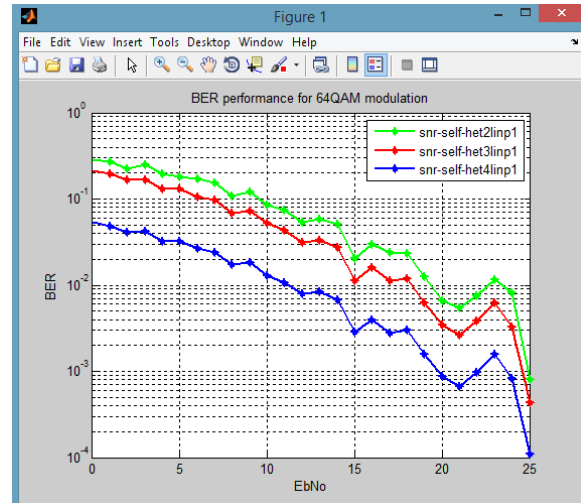

The received bit was compared with transmitted bits in order to calculate the BER in terms of percentages, for each signal to noise power ratio. The simulation was carried out by BER versus SNR performances the 2X2 MIMO self-het OFDM for 64bit QAM is shown in fig 2.2. The input data chosen as random pilot values as 2, 3&4 were mapped into 64QAM constellation. MIMO OFDM multicarrier transmission was carried out using MATLAB application. The received bit were compared with transmitted bits in order to calculate the BER in terms of percentages, for each signal to noise power ratio. The simulation was carried out by BER versus SNR performances.

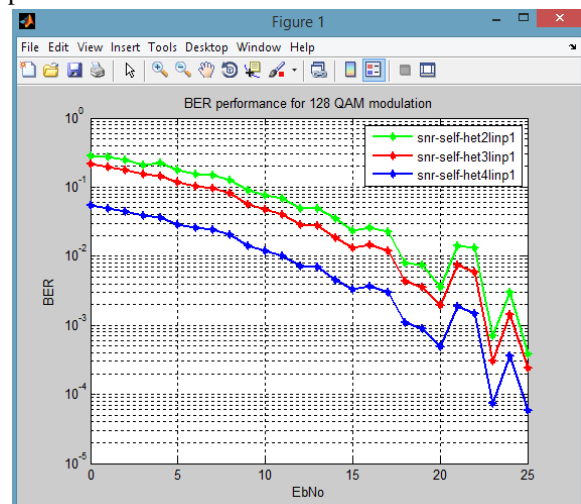

The 2X2 MIMO self-het OFDM for 128bit QAM is shown in fig 2.3. The input data chosen as random pilot values as 2, 3&4 were mapped into 128QAM constellation. MIMO OFDM multicarrier transmission was carried out using MATLAB application.

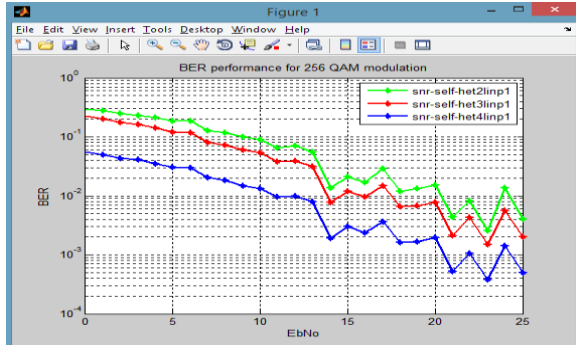

The received bit were compared with transmitted bits in order to calculate the BER in terms of percentages, for each signal to noise power ratio. The simulation was carried out by BER versus SNR performances. The 2X2 MIMO self-het OFDM for 256bit QAM is shown in fig 2.4. The input data chosen as random pilot values as 2, 3&4 were mapped into 256QAM constellation. MIMO OFDM multicarrier transmission was carried out using MATLAB application. The received bit were compared with transmitted bits in order to calculate the BER in terms of percentages, for each signal to noise power ratio. The simulation was carried out by BER versus SNR performances.

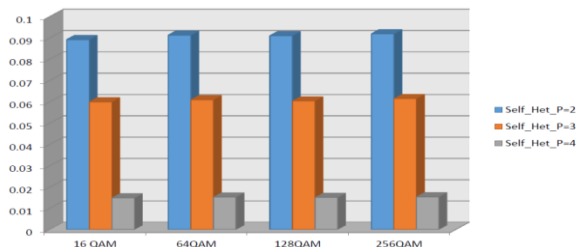

The figure 4.6 shows the performance characteristics of self-het. It represented the different QAM values 16/64/128/256 bits with the pilot values as 2, 3, & 4. To compare all the bit values 16QAM is the lowest signifying high performance with no phase noise. The comparison between the probabilities versus bit values slight variations only take places. As 16QAM is lower than the 64 & 256QAM but the 128QAM is higher than the 16QAM.

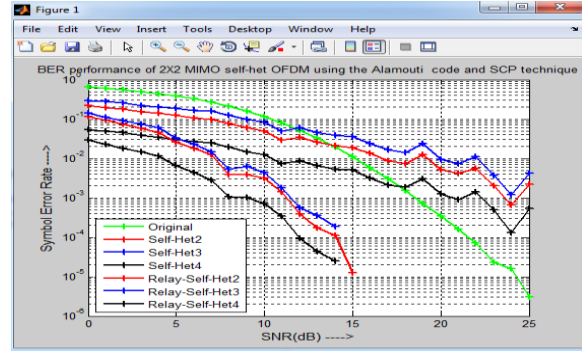

6. CONCLUSION

The 2X2 MIMO Self-Het OFDM system provided with 16, 64, 126, 256 bits data. In that, the Alamouti code sequence with Self-Het Pilot insertion 'P' was chosen as random values as 2, 3 & 4. The BER versus SNR for different bit values for 2X2 MIMO Self-Het system was completed and the performance of the system was compared. From the values obtained it is found that the BER Vs SNR 16QAM is the lowest signifying high performance with no phase noise by Self-Het.

7. REFERENCES

1. Chang-Soon Choi, Yozo Shoji, and Hiroyo Ogawa (2007), "Analysis of receiver space diversity gain for millimeter wave self-heterodyne transmission techniques under two-path Channel environments", *IEEE, National Institute of Information and Communications Technology (NICT), Japan*, pp. 239-0847.
2. Chang-Soon Choi, Yozo Shoji, and Hiroyo Ogawa (2011), "Implementation of an OFDM Baseband with Adaptive Modulations to Grouped Subcarriers for Millimeter wave wireless Indoor Networks", *IEEE Transactions on Consumer Electronics*, Vol. 57, No. 4, pp.0098 3063.
3. Haibing Yang, Peter F.M. Smulders and Matti H.A.J. Herben (2006), "Frequency Selectivity of 60-GHz LOS and NLOS Indoor Radio Channels", *IEEE Transactions on Radio Communications*, pp. 0-7803-9392-9.
4. Ho-Jin Song, Tadao Nagastuma (2011), "Present and Future of Terahertz Communications", *IEEE Transactions on Terahertz Science and Technology*, Vol. 1, No. 1, pp. 2156-342.

5. Nirmal Fernando, Yi Hong, Emanuele Viterbo (2013), "Analysis of Self-het OFDM Enhancements for 60GHz Indoor RF Channels", IEEE, Australian Communications Theory Workshop (AusCTW), pp. 4675-7.

6. Nirmal Fernando, Yi Hong, Emanuele Viterbo (2013), "Self-Heterodyne OFDM Transmission for Frequency Selective Channels", IEEE Transactions on Communications Vol. 61, No.5, pp. 0090-6778.

7. Nirmal Fernando, Yi Hong, Emanuele Viterbo (2013), "Subcarrier Pairing for Self-het OFDM", IEEE ICC Transactions on Communications Theory, pp.3122-7.

8. J.N. Schulman, V. Kolinko, M. Morgan, C. Martin, J. Lovberg, S. Thomas, J. Zinck, and Y.K. Boegeman (2004), "W-Band Direct Detection Circuit Performance with Sb-Heterostructure Diodes", IEEE Microwave and Wireless Components, Vol.14, No.7, pp. 1531-1309.

9. Yozo Shoji, Chang-Soon Choi, and Hiroyo Ogawa (2007), "Millimeter wave OFDM WPAN system applying adaptive modulation for grouped sub-carriers", IEEE National Institute of Information and Communications Technology (NICT), pp. 239-0847.

10. Yozo Shoji, Kiyoshi Hamaguchi, and Hiroyo Ogawa (2002), "Millimeter wave Remote Self-Het System for Extremely Stable and Low Cost Broad Band Signal Transmission", IEEE Transactions on Microwave Theory and Techniques, Vol.50, No.6, pp. 0018-9480.

11. Yozo Shoji, Chang-Soon Choi, and Hiroyo Ogawa (2006), "70GHz Band OFDM Transceivers Based on Self-Het Scheme for Millimeter Wave Wireless Personal Area Network", IEEE Transactions on Microwave Theory and Techniques, Vol.54, No.10, pp.0018-9480.

12. Yozo Shoji and Hiroyo Ogawa (2004), "70GHz Band MMIC Transceiver with Integrated Antenna Diversity System: Application of Receiver Module Arrayed Self-Het Technique", IEEE Transactions on Microwave Theory and Techniques, Vol.52, No.11, pp.0018-9480.

Author Profile 1:



Mr.B.Jayander M.Tech in wireless and mobile communication(wmc),Mallareddy institute of engineering and technology Hyderabad. He completed, B.tech(Electronics &Communication engineering) from SwarnaBharathi college of Engineering,KhammamDist ,TelanganaIndia.His areas of interest wireless communication,digital communication.

Author profile 2:



K.Satyavathi Mtech(Ph.d) completed B.tech 2004 in Electronics and communication Engineering from Nagarjuna institute of engineering and technology, M.tech in digital system &computer electronics(DSCE) from jntuh. Working as an assistant professor in Mallareddy institute of engineering and technology

Author profile 3:



Dr M Narsingh yadav is currently working as Head of the Department in Malla Reddy institute of engineering and technology, Affiliated to JNTU Hyderabad,Telangana.He has completed his B.TECH from Gurunanak Engineering college .affiliated to JNTU Hyderabad University in 2006 and he did masters MS under university of California SAN DIEGO. He did his Ph.D(Wireless networking) ,from university of California, LOS ANGELS in 2010.His area of interest includes ElectronicsAdvanced digital communication and wireless sensor networks.