

# An IOT Approach for designing home automation technique

D. Shirisha & K.R Anusha Hinduja

<sup>[1]</sup>Assistant Professor, Department of ECE, Siddhartha Institute of Science & Technology, Hyderabad, T.S, INDIA

<sup>[2]</sup>Assistant Professor, Department of ECE, SRTIST, Hyderabad, T.S, INDIA

**Abstract:** *In this paper, we are presenting a proposed system for Smart Home Automation technique with Raspberry Pi using IoT and it is done by integrating cameras and motion sensors into a web application. To design this system, we are using a Raspberry Pi module with Computer Vision techniques. Using this, we can control home appliances connected through a monitor based internet. Raspberry Pi operates and controls motion sensors and video cameras for sensing and surveillance. For instance, it captures intruder's identity and detects its presence using simple Computer Vision Technique (CVT). Whenever motion is detected, the cameras will start recording and Raspberry Pi device alerts the owner through an SMS and alarm call.*

*Automation or automatic control means the use of various control systems for operating equipment. Home automation is exciting field when it is blow up with new technologies like Internet of Things (IoT). It is automation of the home, housework or household activity. Proposed implementation of home automation include centralized control of lighting, heating, ventilation and it is fully control by using any smart phone through the particular android application. The main advantage of this is small device can be part of internet so it is easy to communicate, manage and control without human interferences.*

## I. INTRODUCTION

The Internet of Things (IoT) is the network of physical objects or "things" embedded with electronics, software, sensors, and network connectivity, which enables these objects to collect and exchange data [1]. In home automation smart devices and sensors that sense the physical experience and convert into stream of information data. The major element of home automation based on IoT is sensor network and raspberry pi. Sensor networks are used for sensing and monitoring while raspberry pi collect the data monitor the data and depends on collected mange the device like fan, light, door motion and opening-closing of curtains. Suppose the ambient light is less that I am going to feel darkness then according to ambient light its automatically open the curtains. In today's world people are so busy in their life that they prefer automatic systems over manual system [2].

Wireless home automation using IoT is a system that uses computer or mobile devices to control basic home function and feature automatically through internet from anywhere around the world. It save energy and time also helps to old age peoples and disable persons by providing remote control of home appliances. Raspberry pi is used as main part of project; as events are occurred some specified functions are performed accordingly i.e. turn on or off light. Also sense the presence of person and click some picture uploaded it to cloud storage from where we can

collect these. Programming is done using python and HTML [3]. Home automation refers to a system that is used to control devices around the home. These devices can include doors, lights, surveillance systems, and consumer electronics. A user can control a variety of home devices with the help of a home automation system. To provide mobility, a mobile phone-based home automation has been developed. As another approach toward home automation, an Internet based home automation system has been proposed, providing a graphic user interface.

## II. PROPOSED SYSTEM

In the proposed system design and implementation of Secure Home Automation using Raspberry Pi for mobile devices that leverage mobile technology to provide essential security to our homes and associated control operations. The proposed home security solution hinges on our novel integration of cameras and motion detectors into web application. Raspberry Pi operates and controls motion detectors and video cameras for remote sensing and surveillance, streams live video and records it for future playback, and finally manages operations on home appliances, such as turning ON/OFF a television or microwave. For instance, when motion is detected, the cameras automatically initiate recording and the Raspberry Pi device alerts the homeowner of the possible intrusion. Raspberry Pi has two main components interacting with each other: the Web application that executes on the mobile device's browser and server-side scripts that run in a cloud which will be operated by the Raspberry Pi hardware tool component.

The main aim of the system design is that the user can control the home appliances through

mobile or laptop having internet facility using Raspberry Pi. A program is written to control home appliances and to get the current status (i.e, OFF or ON) of the appliances and to get the live streaming from camera connected to Raspberry Pi. It uses this program to get the status of appliances and to store the status on the database of website and it displays the current status of appliances and live streaming on monitor connected through HDMI port.

It is also used to stream video online i.e, we can see the live streaming anywhere through internet. We can connect it to several monitors at a time using HDMI extension switch. Thus Raspberry Pi will act as the central authority for controlling the home appliances and website database as well.

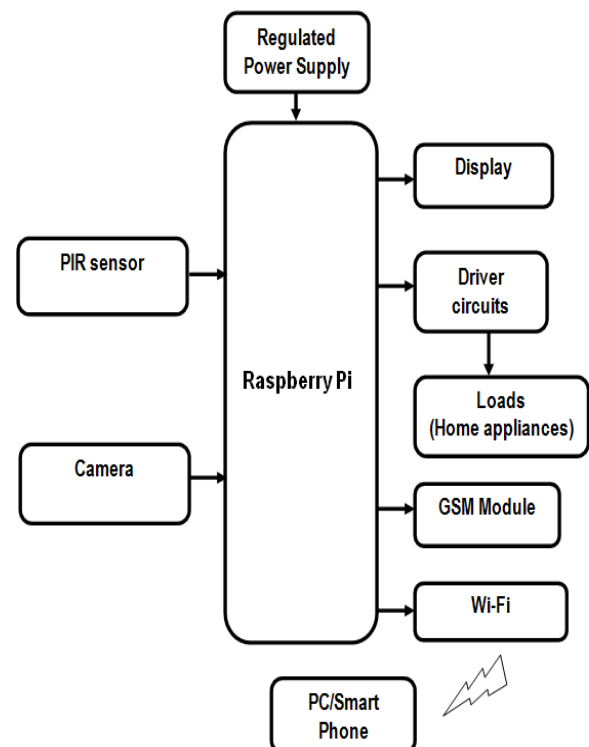
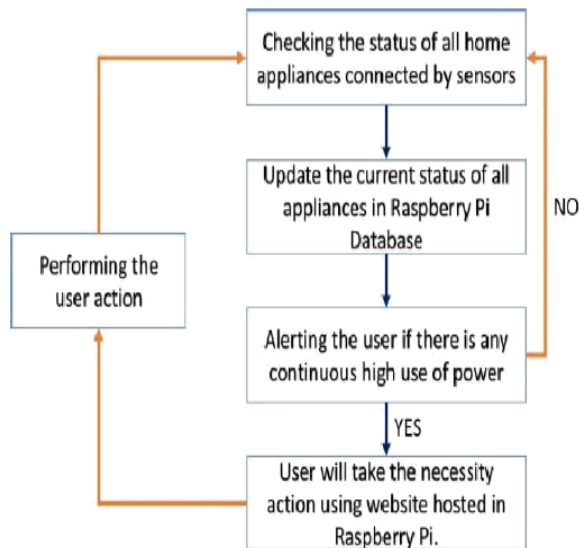

Figure 1: Block Diagram

## III. WORKING PRINCIPLE

In Raspberry Pi, Raspian operating system [4] is installed. This Operating System is a Linux based one and it supports all programming languages like Python, C, C++ etc.



**Figure 2: flow chart representation of working principle**

Out of those, Python programming language is used in this system to communicate with General Purpose Input Output Ports and simple connection is made with databases using MYSQLDB [5] and Simple CV [6] modules. For sending SMS to alert the user Serial module is used.

The proposed system can be demonstrated with the help of following steps:

- Import all the required modules i.e, Simple CV, MYSQLDB, Serial Module;
- Check the status (ON/OFF) of all home appliances connected to Raspberry Pi;
- Update the website database of appliances with the current status;
- Check whether the Raspberry Pi captures the surroundings using the camera;
- Using Simple CV, find whether the motion is present;

- If there is motion alert the user about the motion through SMS using GSM connected Raspberry Pi;
- If there is no motion Surveillance, check it continues the process from the beginning;

Whenever there is change in status of appliances then the changes are updated in website database.

#### IV. EXPERIMENTAL RESULTS

The system consists of mainly 3 components is a Wi-Fi module, raspberry pi board and relay circuits. Wi-Fi is used a communication channel between web interface and raspberry pi board. This provides a full security support for homes. This system is more flexible and provides attractive user interface compared to other home automation systems.



**Figure 3: Hardware implementation**

Below figure shows the website containing the status of all the home appliances and live status from the camera connected to Raspberry Pi.

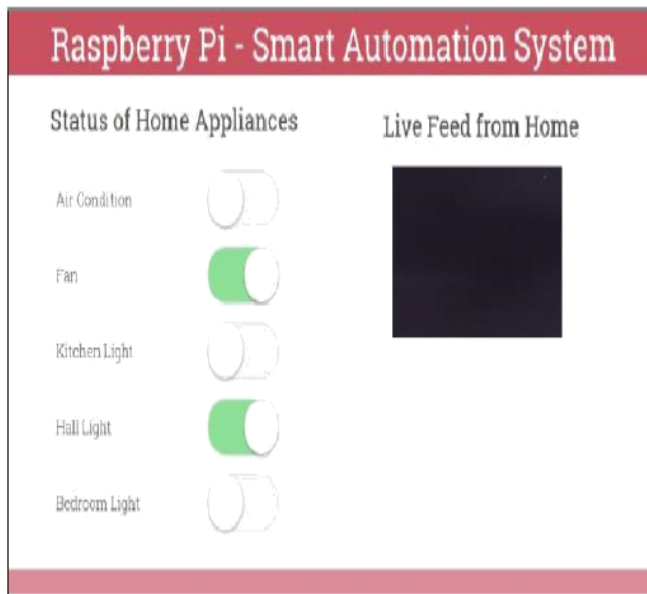

**Figure 4: Website Showing the Status of Appliances and Live Status from Camera**

## V. CONCLUSION

The application of the IoT technology, in home automation means combination of all electrical devices like smart mobile phone, personal computer, tablet and their monitoring, controlling and alerting in ways not possible before. This proposed system provides many advantages including, safety, security, improved comfort, energy and cost savings. In order to address the issues of flexibility and functionality, a novel, standalone, flexible and low cost home controlling and monitoring system using Web services as an interoperable layer for communicating between the remotely present user and the home devices, have been designed.

### Future Enhancements

In future works, it is planned the development of new modules to reduce the energy necessary for surveillance cameras. By adding a solar energy

panel, the camera will be capable of harvesting the solar energy and be wireless. With a very low power Wi-Fi module, it will be able to upload the recorded videos to a server. In addition, to control all the modules, in order to keep the performance and control the energy usage through periods of little or no solar energy supplied, there will be a control module.

## REFERENCES

1. "Internet of Things Global Standards Initiative". ITU. Retrieved 26 June 2015.
2. Baris Yuksekkaya, A. Alper Kayalar, M. Bilgehan Tosun, M. Kaan Ozcan, and Ali Ziya Alkar "A GSM, Internet and Speech Controlled Wireless Interactive Home Automation System", 2006, IEEE Transactions on Consumer Electronics, Vol. 52(3), pp. 837 – 843
3. Rozita Teymourzadeh, Salah Addin Ahmed, Kok Wai Chan and Mok Vee Hoong, "Smart GSM Based Home Automation System", 2013, IEEE Conference on Systems, Process & Control, Kuala Lumpur, Malaysia.
4. Raspberry Pi Foundation, <http://www.raspberrypi.org>
5. Python Software Foundation[US], <https://pypi.python.org/pypi>
6. SimpleCV. <http://www.simplecv.org>

### Author's Profile



**D. Shirisha** was born in Hyderabad, India, in 1986. She received M.Tech degrees from JNTUH, India, in 2014 and currently working as an Assistant Professor at “**Siddhartha Institute of Science & Technology**”, Ghatkesar, Hyderabad, India.



**K.R Anusha Hinduja** she received M.TECH degree from JNTUH, India, and currently working as an Assistant Professor at “**Swami ramananda thirtha Institute of Science & Technology**”, Nalgonda India.