

# Study of Design of Superconducting Magnetic Energy Storage Coil for Power System Applications

**Ravi Khemchandani; Ashish Nipane Singh & Hitesh Khanna**

Research Scholar in Dronacharya College of Engineering Gurgaon

Email: [hiteshkhanna98@yahoo.in](mailto:hiteshkhanna98@yahoo.in)

## Abstract

*This paper presents the modeling of Superconducting Magnetic Energy Storage (SMES) coil. A SMES device is dc current device that stores energy in the magnetic field. A typical SMES system includes three parts: Superconducting Coil, Power Conditioning System and Cryogenically Cooled Refrigeration. This paper discusses a design of 50 MW, 100 MJ SMES coil with simulation result and also analyses the effect of various design parameters on the capacity of coil.*

Keywords—

SMES;pancakes;inductance;capacitance; coil.

## I. INTRODUCTION

Superconducting Magnetic Energy Storage (SMES) is an energy storage technology that stores energy in the form of DC electricity that is a source of the DC magnetic field with near zero loss of energy. It stores energy by the flow of DC in a coil of superconducting material that has been cryogenically cooled. SMES is the only technology based on superconductivity that is applicable to electrical utilities and is commercially available today. The historical development of SMES starting with the concept of very large plants that would store hundred of megawatt hours of energy and were intended for load leveling was described. SMES was originally conceived as a source of

energy to accommodate the variation of power demand .In 1969, Ferrier proposed a single large unit to meet the daily variation in power in France. The original concept contained three major components: superconducting magnet, a refrigeration system to maintain magnet, and interface between the direct current in the magnet and power grid. Then SMES system was developed and marketed by ASC (American Superconductor Corporation).

The design methodology of SMES is studied .Various alternatives in designing the coil are obtained and detailed analysis is also studied. Here each turn or section of the coil is represented with its series capacitance, shunt capacitance, self and mutual inductance. To get accurate voltage and frequency response, it is necessary to consider mutual inductance linkages between segments of the coil. The formula of equivalent series capacitance of a coil is used to determine the natural frequency of energy storage magnet. While the analytic formula is used for calculating the disk capacitance with variable number of wound on shield turns. The experimental results provide a useful tool for power utility engineers to evaluate SMES system. The historical perspectives of SMES system helped in improvement and development of SMES system [6]. The purpose of this study is to observe the effects of changes in parameters on the capacity of SMES coil. The SMES coil design is chosen and analysed as most suitable for practical power system needs. The SMES coil is new concept for the development of power system.

## II. THE STRUCTURE OF SMES

The main part of the SMES systems is a large superconducting coil. It is contained in a cryostat (or Dewar) that consists of a vacuum vessel and liquid vessel that cools the coil. A cryogenic system is to keep the temperature well below the critical temperature for the Superconductor. An ac/dc power conversion or conditioning system (PCS) is used for two purposes; one is to convert from dc to ac, and the other is to charge and discharge the coil. A transformer provides the connection to the power system and reduces the operating voltage to acceptable levels for the PCS. Fig. 1 shows the general structure of a SMES system.

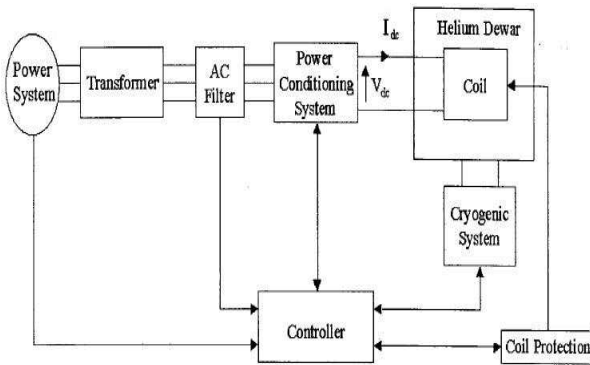

Fig. 1. Structure of SMES

### III. DESIGN OF SMES COIL COMPONENTS

A number of methods are available to develop model of the Superconducting coil or building a mathematical model. A lumped Parameter network model is chosen because of its advantages. A lumped Parameter network model contains agnetic and dielectric coil parameters, which have the following set of elements:

- A magnetic circuit is represented by self and mutual inductance ( $L$  and  $M$ ) of each turn.
- The dielectric circuit is represented by capacitances between adjacent turns ( $C_{adj}$ ), axially separated turns ( $C_{ax}$ ) and turn to the outside surface ( $C_g$ ).

An electrical lumped parameter model is constructed for a superconducting coil. It is assumed that the coil consists of a number of disks (pancakes) comprised of a number of turns. Given the geometrical dimension of a coil, the parameters like self inductance, mutual inductance, adjacent capacitance, axial capacitance, capacitance to ground are calculated for each turn of the coil. In order to avoid computing cost, a lumped double pancake parameter model is developed using the parameters computed for turns. In transient analysis simulations, representing the first and last few double pancakes with turn-to-turn representation can satisfy the requirement for the detailed modeling of Superconducting coil. The design of Superconducting coil is explained in following section.

- Superconducting coil

The lumped parameter model of the superconducting coil consist of magnetic and dielectric ckt, which having the capacitance and

inductances in the coil. The inductance (self and mutual inductances) has been equally divided among the different six segments of the SMES coil. Each segment represents eight of the double pancakes lumped together and hence, the SMES coil having 48 double pancakes. However, this detailed model requires more memory and computing time if the coil consists of excessive numbers of turns.  $N$  number of turns in a  $N_{dp}$  number of double pancakes in a coil can be lumped to model the coil in the level of double pancakes. The entire SMES coil has a width/ height ratio of 3.66 m (144 in) / 1.53 m (60 in). A MATLAB is used to calculate electrical parameters for each double pancake. The self and mutual inductances for each turn also have been lumped to obtain the equivalent self and mutual inductances for each double pancake. The total inductance is found to be ( $L$ ) 12.5 H. Fig. 2 shows SMES coil model. The stored energy in the SMES coil can be calculated by the formula:

$$E = \frac{1}{2} I^2 M^2 L S \quad (1)$$

where  $E$  is the SMES energy;  $ISM$  is the SMES Current and  $LSM$  is the SMES inductor of coil.

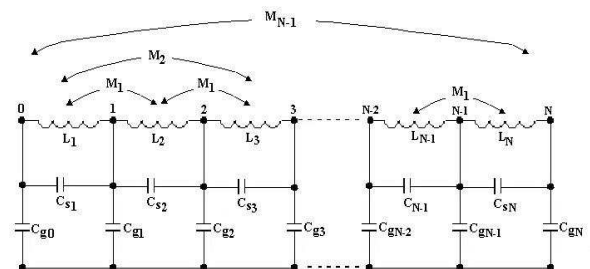
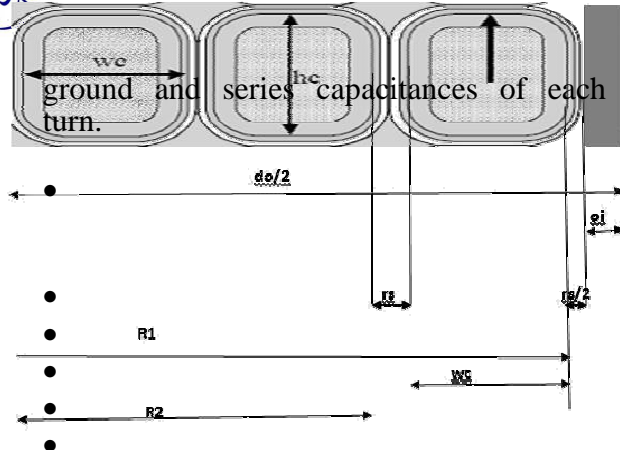

Fig. 2. Simplified model of a superconducting (SMES) coil

The following assumptions are made throughout the modeling:

- The dielectric constant of the insulating material does not vary with frequency.
- The thermal enclosure and the tank do not carry current, and they were represented as ground plane
- A small value of resistor represents skin effect and eddy current losses.
- Parallel plate model is employed to calculate



- To reduce the computing cost, each double pancake (two single pancakes) is represented by its series inductance, capacitance, and mutual inductance and ground capacitances, and mutual inductance and ground capacitances

Forming Inductance Matrix for self and mutual inductance is as follow:

- Let self inductances for each turn in a SP are calculated by applying the Miki's formula, and mutual inductances between each turn in a SP by applying the Lyle's method.
- Let a NxN matrix block be constructed where N is the number of turns in a SP. Diagonal elements correspond to the self inductances and off-diagonal elements correspond to mutual inductances between each turns in a SP.
- Let Lyle's method be applied to calculate mutual inductances between turns in the first SP and turns in the other SPs. A series of NxN matrix blocks are constructed where each NxN represents mutual inductances between the first SP and other SPs.
- Once the first column of L turn is formed, a lumped inductance matrix representing the double pancakes of the coil is computed.

The most detailed mathematical model for a coil can obtained if each turn in the coil is represented

by its associated L, M, Cadj, Cax, and Cg. The main task to complete calculation of SMES is divided in to following:

- SMES Capacitance Calculations
- SMES Self and Mutual Inductance Calculation

Fig. 3. Representation of turns for understanding the notations of coil parameters

### A. SMES Capacitance Calculations

Capacitance calculations depends on formula is given below

$$C = \frac{(\mu A)}{d} \tag{2}$$

where A is the surface area between turns (conductors) or turn to ground, d is the distance between bare conductors. According to Figure.2 for 100 MJ SMES coil shunt capacitance and series capacitance is found to be (Centire coil series=0.83669587 nf & Centire coil shunt=0.044517362311nf)

Calculating Capacitances for a double pancake:

1. Calculate capacitances between adjacent turns (Cad), axially separated turns (Cax) and turns to ground (Cg).
2. Capacitances between adjacent turns and axially separated turns are combined in such way which shown in Figure 4 to compute the equivalent series capacitance for a double pancake.
3. Ground capacitances calculated for each turn within a double pancake are summed to obtain an equivalent ground capacitance for a double pancake.

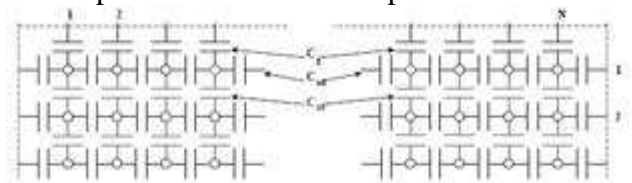

Fig. 4. Capacitive parameters in the entire coil

where,  $C_{ad}$  = Capacitance between adjacent turns within a disc coil,  $C_{ax}$  = Capacitance between axially separated turns,  $C_g$  = Capacitance between turn and a ground,  $N$  = Number of turns in a single pancake,  $N_{sp}$  = Number of single pancakes

**B. SMES Self and Mutual Inductance Calculation**

The formula to compute the self-inductance (in Henry) as follows [1]

$$L = \mu_0 RN^2 \left( \ln\left(\frac{8R}{R_1}\right) - 2 \right),$$

$$\ln R_1 = \frac{1}{2} \ln(a^2 + b^2) - \frac{b^2}{12a^2} \ln\left(1 + \frac{a^2}{b^2}\right) - \frac{a^2}{12b^2} \ln\left(1 + \frac{b^2}{a^2}\right) + \frac{2b}{3a} \tan^{-1} \frac{a}{b}$$

$$+ \frac{2a}{3b} \tan^{-1} \frac{b}{a} - \frac{25}{12}$$

(3)

where,  $N$  is the number of turns in a pair of disk coils (double pancake). If the inductance of a turn is to be calculated, then  $N$  is equal to 1. Mutual inductance between two circular filaments is calculated using the formula developed by Maxwell. [2]

$$M_{1-2} = \mu_0 \sqrt{(R_1 R_2) \left[ \left(\frac{c}{R_1}\right)^2 - k \right] K(k) - \frac{R_1 R_2}{c} E(k)}$$

$$K = \sqrt{\frac{4R_1 R_2}{(R_1 + R_2)^2 + d^2}}$$

(4)

Where  $R_1$  and  $R_2$  are the radius of the circular filaments 1 and 2,  $d$  is the distance between circular filaments,  $K(k)$  and  $E(k)$  are the complete elliptic integrals of the first and second kind.

With the help of Lyle’s method the mutual inductance between turns or coil calculated. Lyle’s method states that each coil (Coils 1 and 2) can be represented by two equivalent filaments as shown in Fig. 5.

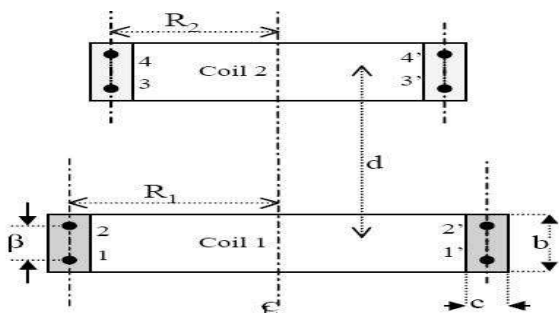

Fig. 5. Coil representation by Lyle’s method (for  $b > c$ ).

Mutual inductance between each equivalent filament (11’-33’, 11’-44’, 22’-33’ and 22’-44’) is calculated using Equation (4), where  $R_1$  and  $R_2$  are replaced with an equivalent radii of  $r$  and spacing between coils vary between  $d + 2\beta$  and  $d - 2\beta$  in (5)

$$r_i = R_i \left( 1 + \frac{c^2}{24R_i^2} \right), \beta = \sqrt{\frac{b^2 - c^2}{12}}$$

(5)

The average of each calculated mutual inductance gives the mutual inductance between the two coils.

**IV. EFFECT OF VARIOUS DESIGN PARAMETERS ON THE CAPACITY OF SMES:**

The effects of various design parameters on the SMES coil under consideration are analyzed. It is observed that the number of double pancakes in the coil, outer diameter of magnetic coil and number of turns in one single pancake has significant influence on the capacity of SMES coil. These effects are studied by varying these parameters.

- Effect by variation of number of double pancakes [ $N_{dp}$ ]:-

If the number of double pancakes is increased, series and shunt capacitance of coil decreases thereby increasing total inductance of the coil. The energy storage capacity of the coil is increased. Here the number of double pancakes are varied from 10, in the step of 10 till 100. It is observed that for every change in 10 numbers of double pancakes, there is rise of storage capacity from 3MJ to 264MJ. As shown below fig. 6 gives the variation of number of double pancakes with energy

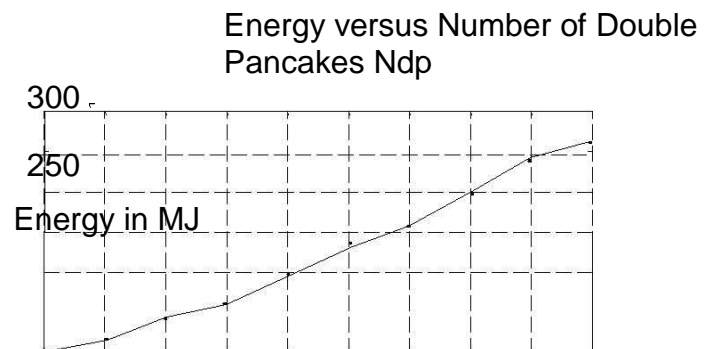

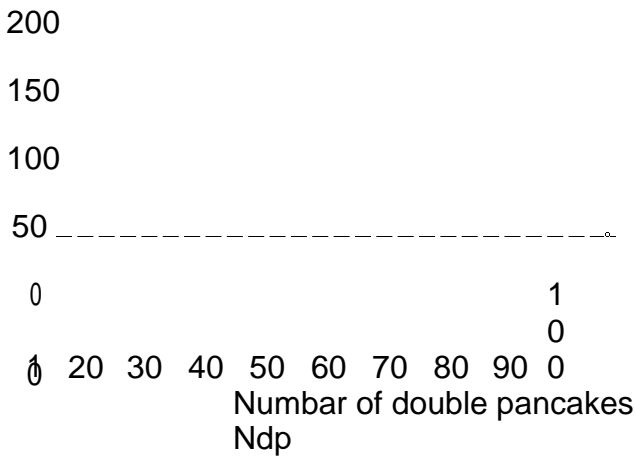

Fig. 6. E -Ndp curve of the SMES coil.

- Effect by variation of outer diameter [do]:

If the outer diameter is increased, series and shunt capacitance of coil increases thereby increasing total inductance of the coil. The energy storage capacity of the coil is increased. Here the outer diameter is varied from 144, in the step of 10 till 194. It is observed that for every change in 10 outer diameters, there is rise of storage capacity from 12MJ. As shown below fig. 7 gives the variation of outer diameter with energy.

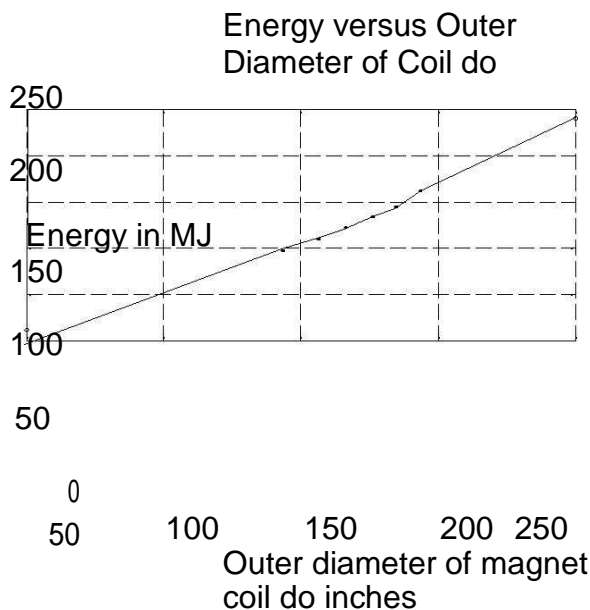

Fig .7. E-do curve of the SMES coil.

- Effect by variation of Number of turn in single pancake (N):-

If the number of turn in single pancake is increased, series capacitance of coil increases, shunt capacitance of coil decrease, thereby increasing total inductance of the coil. The energy storage capacity of the coil is increased. Here the Number of turn in single pancake is varied from 20, in the step of 20 till 100. It is observed that for every change in 20 number of turn in single pancake, there is rise of storage capacity from 100 to 1008MJ.As shown in below fig. 8 gives the variation of number of turn in single pancake with energy.

#### Energy versus Number of Turns in a Single Pancake N

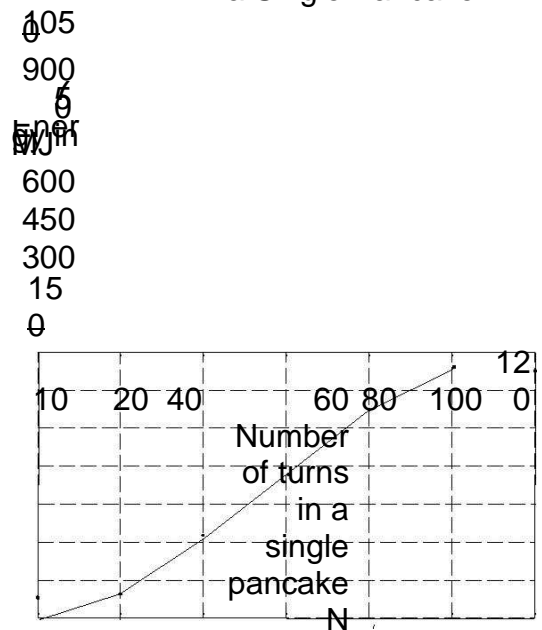

Fig .8. E-N curve of the SMES coil.

- Number of sections, radial conduit spacing of one turn, vertical conduit spacing of one turn and thickness of the conduit of one turn are the major factors affecting the energy storage capacity.

#### V. CONCLUSION

The SMES coil for 50 MW (96 MW peak),

100 MJ, 24 KV is designed using electrical lumped parameter model. A detailed modeling of the coil is necessary to identify the transients better. It is found that the number of double pancakes [Ndp]-48, outer diameter of the magnet coil [do] inches-144, number of turns in one single pancake [N]-20 are required for getting 100MJ capacity. The attempt is made to observe the impact of various design parameters on the capacity of the SMES coil. After the variation in step 10 for

#### REFERENCES

[1] IEEE Task Force on Benchmark Models for Digital Simulation of FACTS and Custom-Power Controllers, T&D Committee, "Detailed

Modeling of Superconducting Magnetic Energy Storage (SMES)

System," IEEE Trans on Power Delivery, vol. 21, no. 2, pp. 699-710, April 2006

[2] K.A. Wirgau, "Inductance Calculation of an Air-Core Disk Winding,"

IEEE Transactions on Power Apparatus and Systems, vol. PAS-95, no. 1, p. 394-400, Jan/Feb, 1976.

[3] P. A. Abetti and F. J. Maginniss, "Natural frequencies of coils and windings

Ndp, do and 20 for N, there is rise in capacity of the SMES coil. It is seen that the change in the parameter Number of turns in one single pancake N is more sensitive, which increase capacity fastly. Number of sections does not affect the parameters of the coil so lumping the double pancake parameters is a valid step in coil modeling. The SMES found large application in power system such as, power system transmission control and stabilization and also improves power quality for critical load.

determined by equivalent circuit," AIEE Trans., pt. III, vol. 72, pp. 495-404, Jun. 1953.

[4] P. Chowdhury, "Calculation of series capacitance for transient analysis of windings," IEEE Trans. Power Del., vol. PWRD-2, no. 1, pp. 133-139, Jan. 1987.

[5] R. M. Del Vecchio, B. Poulin, and R. Ahuja, "Calculation and

Measurement of Winding Disk Capacitances with Wound-in-Shields", IEEE Transactions on Power Delivery, Vol. 13, No. 2, pp 503-509, April 1998

[6] W. V. Hassenzahl, "Superconducting magnetic energy storage," IEEE Trans. Magn., vol. 25, no. 2, pp. 750-758, Mar. 1989.