

# A Single Dc Source Cascaded Seven Level Inverter with Lcl Filter Integrating Switched Capacitor Techniques

C.Sukumar & Dr.Chidhambaraiah Setty

#1 M.tech Student, #2 Professor, Department of EEE

St.Johns College of Engineering &Technology, Yerrakota, Yemmiganur, Kurnool, Andhra Pradesh

**ABSTRACT:** Compared to existing CH-MLI system proposed CH-MLI system is replace all DC sources to capacitors except only one H- Bridge (it is with real DC source) and adds two switches for capacitor charging and discharging purpose. So capacitor charging is independent of Load. Beside the topology of the power electronic interface, the output filter also affects the quality of the load voltage .proposed a 7-level inverter is presented for grid integration systems along with its output LCL filter design. Analytical calculation of losses for the 7-level inverter and the output LCL filter is presented. It is also compared to the H-bridge inverter in terms of output voltage and current harmonics, and the overall losses. Capacitor voltage for desired level can be controlled using carrier phase shifted sinusoidal pulse width modulation (CPS- PWM) strategy instead of complex voltage control algorithms.

## I. INTRODUCTION

MULTILEVEL converters are finding considerable attention in academia and industry as one of the preferred choices for high power conversion applications, such as traction drives, active filters, reactive power compensators, photovoltaic power conversion, uninterruptible power supplies, static compensators and flexible AC transmission systems [1]-[4]. In general, multilevel converters are classified into diode-clamped [5], flying capacitor [6], and cascaded multilevel inverter topologies [7]. A particular attention has been given to cascaded multilevel topology because of its modularity, symmetrical structure and simplicity of control. switches. The objective of this paper is to propose a new inverter topology for multilevel voltage output. This topology is designed based on cascading technique and the number of output levels is improved. It will need  $n$  isolated sources for  $2n+1$  levels of output. ACMI increases the power quality, but they lose modularity and still need more than one isolated sources. A control and hardware strategies for a 27-level ACMI is proposed to reduce the nine power supplies to only four, all of them unidirectional. This system required only one input

DC source. For normal Cascaded H-Bridge Multi Level Inverter (CH-MLI) is used three input sources for seven levels. Compared to existing CH-MLI system proposed CH-MLI system is replace all DC sources to capacitors except only one H- Bridge (it is with real DC source) and adds two switches for capacitor charging and discharging purpose. In this system a single input DC source is integrated with switched capacitor technique, used in seven level cascaded H-Bridge multi level inverter topology. Main advantages is Two switches used, High efficiency, Switching losses can be reduced.

## II. MULTILEVEL INVERTER

An inverter is an electrical device that converts direct current (DC) to alternating current (AC); the converted AC can be at any required voltage and frequency with the use of appropriate transformers, switching, and control circuits. Static inverters have no moving parts and are used in a wide range of applications, from small switching power supplies in computers, to large electric utility high-voltage direct current applications that transport bulk power. Inverters are commonly used to supply AC power from DC sources such as solar panels or batteries. The electrical inverter is a high-power electronic oscillator. It is so named because early mechanical AC to DC converters were made to work in reverse, and thus were "inverted", to convert DC to AC.

### 2.1 Cascaded H-Bridges inverter

A single-phase structure of an  $m$ -level cascaded inverter is illustrated in Figure 1. Each separate dc source (SDCS) is connected to a single-phase full-bridge, or H-bridge, inverter. Each inverter level can generate three different voltage outputs,  $+V_{dc}$ ,  $0$ , and  $-V_{dc}$  by connecting the dc source to the ac output by different combinations of the four switches,  $S_1$ ,  $S_2$ ,  $S_3$ , and  $S_4$ . To obtain  $+V_{dc}$ , switches  $S_1$  and  $S_4$  are turned on, whereas  $-V_{dc}$  can be obtained by turning on switches  $S_2$  and  $S_3$ . By turning on  $S_1$  and  $S_2$  or  $S_3$  and  $S_4$ , the output voltage is  $0$ . The ac outputs of each of the different full-bridge inverter

levels are connected in series such that the synthesized voltage waveform is the sum of the inverter outputs. The number of output phase voltage levels  $m$  in a cascade inverter is defined by  $m = 2s + 1$ , where  $s$  is the number of separate dc sources. An example phase voltage waveform for an 11-level cascaded H-bridge inverter with 5 SDCSs and 5 full bridges

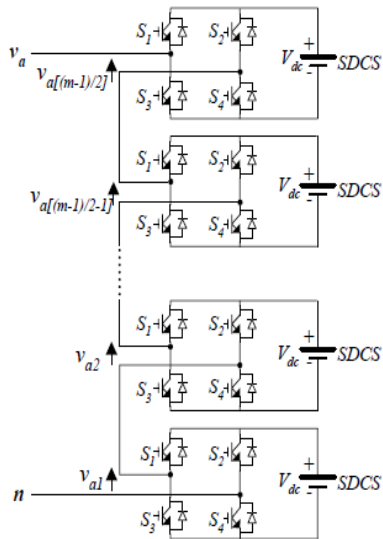

Fig.1 Single-phase structure of a multilevel cascaded H-bridges inverter

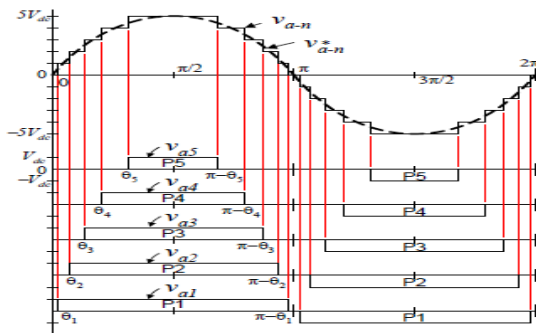

Fig.2 Output phase voltage waveform of an 11-level cascade inverter with 5 separate dc sources.

The magnitudes of the Fourier coefficients when normalized with respect to  $V_{dc}$  are as follows:

The conducting angles,  $\theta_1, \theta_2, \dots, \theta_s$ , can be chosen such that the voltage total harmonic distortion is a minimum. Generally, these angles are chosen so that predominant lower frequency harmonics, 5th, 7th, 11th, and 13th, harmonics are eliminated. More detail on harmonic elimination techniques will be presented in the next section. Multilevel cascaded inverters have been proposed for such applications as static var generation, an interface with renewable energy sources, and for battery-based applications. Three-phase cascaded inverters can be connected in wye, as shown in Figure 4.3, or in delta. Peng has demonstrated a prototype multilevel cascaded static var generator connected in parallel with the electrical system that could supply or draw reactive current from an electrical system. The inverter could be controlled to either regulate the power factor of the current drawn from the source or the bus voltage of the electrical system where the inverter was connected.

Peng and Joos have also shown that a cascade inverter can be directly connected in series with the electrical system for static var compensation. Cascaded inverters are ideal for connecting renewable energy sources with an ac grid, because of the need for separate dc sources, which is the case in applications such as photovoltaic's or fuel cells. Cascaded inverters have also been proposed for use as the main traction drive in electric vehicles, where several batteries or ultra capacitors are well suited to serve as SDCSs. The cascaded inverter could also serve as a rectifier/charger for the batteries of an electric vehicle while the vehicle was connected to an ac supply as shown in Figure 4.3. Additionally, the cascade inverter can act as a rectifier in a vehicle that uses regenerative braking.

The main advantages and disadvantages of multilevel cascaded H-bridge converters are as follows

#### Advantages

- The number of possible output voltage levels is more than twice the number of dc sources ( $m = 2s + 1$ ).
- The series of H-bridges makes for modularized layout and packaging. This will enable the manufacturing process to be done more quickly and cheaply.

### III. PROJECT DESCRIPTION

MULTILEVEL converters are finding considerable attention in academia and industry as one of the preferred choices for high power conversion applications, such as traction drives, active filters, reactive power compensators, photovoltaic power conversion, uninterruptible power supplies, static

compensators and flexible AC transmission systems [1]-[4]. In general, multilevel converters are classified into diode-clamped [5], flying capacitor [6], and cascaded multilevel inverter topologies [7]. A particular attention has been given to cascaded multilevel topology because of its modularity, symmetrical structure and simplicity of control switches.

Cascade multilevel inverters have been developed for electric utility applications. A cascade M-level inverter consists of  $(M-1)/2$  H-bridges in which each bridge's dc voltage is supported by its own dc capacitor. The new inverter can: (1) generate almost sinusoidal waveform voltage while only switching one time per fundamental cycle; (2) dispense with multi-pulse inverters' transformers used in conventional utility interfaces and static var compensators; (3) enables direct parallel or series transformer-less connection to medium- and high-voltage power systems. In short, the cascade inverter is much more efficient and suitable for utility applications than traditional multi-pulse and pulse width modulation (PWM) inverters. The authors have experimentally demonstrated the superiority of the new inverter for power supply, (hybrid) electric vehicle (EV) motor drive, reactive power (var) and harmonic compensation. This paper summarizes the features, feasibility, and control schemes of the cascade inverter for utility applications including utility interface of renewable energy, voltage regulation, var compensation, and harmonic filtering in power systems. Analytical, simulated, and experimental results demonstrated the superiority of the new inverters.

### 3.1 PHOTO VOLTALIC SYSTEM

A photovoltaic system, also solar PV power system, or PV system, is a power system designed to supply usable solar power by means of photovoltaics. It consists of an arrangement of several components, including solar panels to absorb and convert sunlight into electricity, Photovoltaic's (PV) is the name of a method of converting solar energy into direct current electricity using semiconducting materials that exhibit the photovoltaic effect, a phenomenon commonly studied in physics, photochemistry and electrochemistry. The direct conversion of sunlight to electricity occurs without any moving parts or environmental emissions during operation.

#### PV PANEL

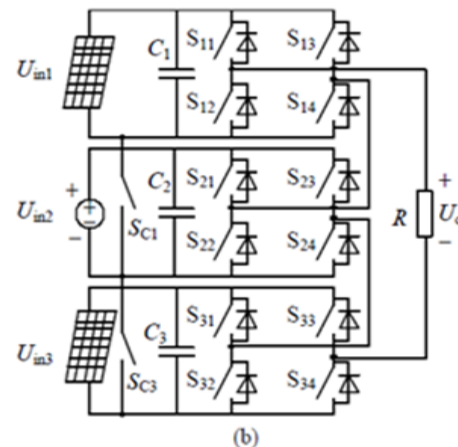

Topologies of the proposed inverter. (a) The novel single dc source cascaded seven-level inverter. (b) Three-input cascaded

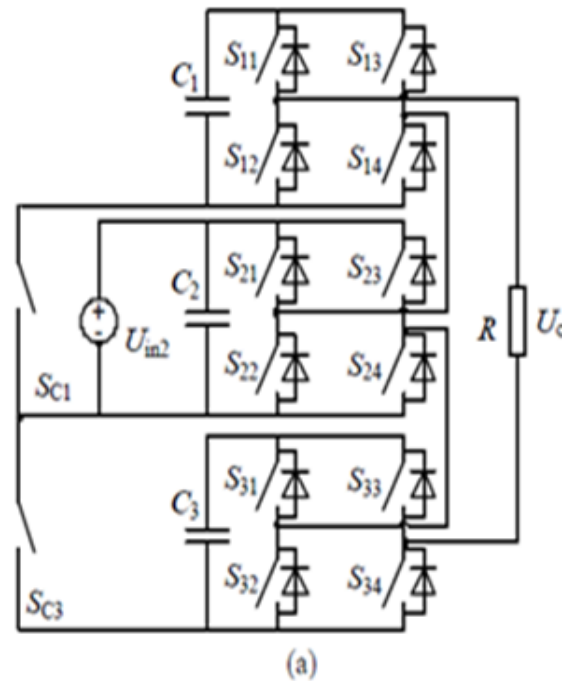

The capacitor charging time is related to the modulation sine wave value  $m$ . For simplicity, the charging time for  $C1$  is taken as an example to have a detailed analysis. When  $m$ , the modulation wave  $Z1$  lags behind  $Z2$  by  $TS/6$ , as shown .

- At this stage, the falling edge of  $g13$  and the rising edge of  $g21$  move forward or backward with the variation in  $m$ . However, the overlapping portions of  $g13$  and  $g21$  remain unchanged; thus, the charging time remains  $TS/6$ .
- The output voltage of the inverter is 0 or  $U_{in2}$  when  $m$  and  $U_{in2}$  or  $2U_{in2}$  is turned off after  $S13$ . The charging time is  $(1-m)TS/2$ , and the output voltage of the inverter is  $2U_{in2}$  or  $3U_{in2}$ . And capacitor voltage  $U_{C1}$  would decrease drastically if the modulation wave is increased to 1; however, it would recover in time if the modulation wave is decreased.
- Due to the symmetry, the charging time and the output voltage can be easily derived with  $m < 0$ . The charging time and the output voltage in different  $m$ .

### 3.2 OPERATION MODES

#### A.Mode I ( $t_0 < t < t_1$ )

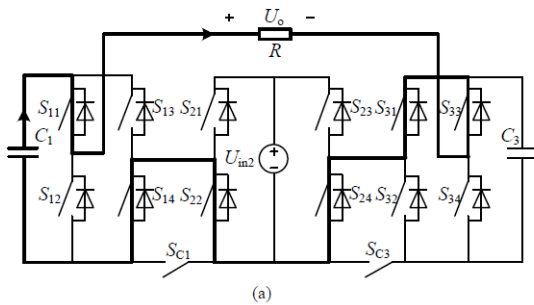

State I: Capacitor  $C1$  operates individually.  $S11$ ,  $S14$ ,  $S22$ ,  $S24$ ,  $S31$ , and  $S33$  are turned on simultaneously for status 7 ( $S11$ ,  $S14$ ,  $S21$ ,  $S23$ ,  $S32$ , and  $S34$  are on for status 8). The equivalent circuit of status 7 is shown.  $U_{C1}$  can be expressed as

#### B. Mode II ( $t_1 < t < t_2$ )

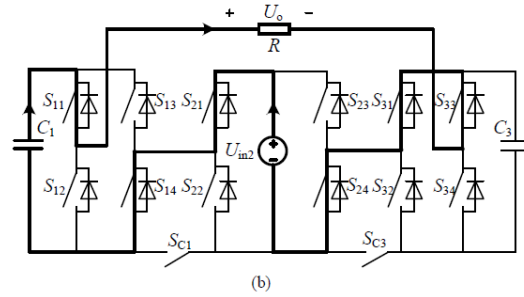

State II: Capacitor  $C1$  and  $U_{in2}$  operate simultaneously.  $S11$ ,  $S14$ ,  $S21$ ,  $S24$ ,  $S31$ , and  $S33$  are turned on simultaneously for status 9 ( $S11$ ,  $S14$ ,  $S21$ ,  $S24$ ,  $S32$ , and  $S34$  are on for status 10). The equivalent circuit of status 9 is shown  $U_{C1}$  is provided by

#### C. Mode III ( $t_2 < t < t_3$ )

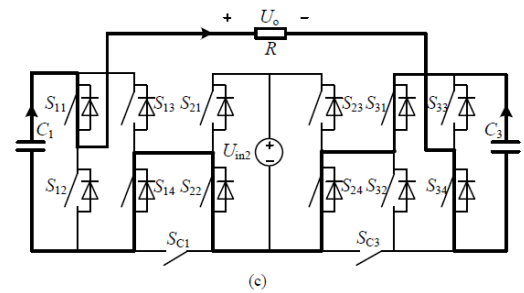

State III: Capacitors  $C1$  and  $C3$  operate simultaneously.  $S11$ ,  $S14$ ,  $S22$ ,  $S24$ ,  $S31$ , and  $S34$  are turned on simultaneously for status 11 ( $S11$ ,  $S14$ ,  $S21$ ,  $S23$ ,  $S31$ , and  $S34$  are on for status 12). The equivalent circuit is shown  $U_{C1}$  can be expressed as

#### D. Mode IV ( $t_3 < t < t_4$ )

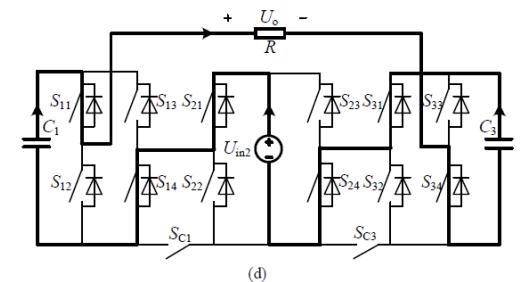

State IV: Capacitors  $C1$ ,  $C3$ , and  $U_{in2}$  operate simultaneously.  $S11$ ,  $S14$ ,  $S21$ ,  $S24$ ,  $S31$ , and  $S34$  are turned on simultaneously for status 13. The equivalent circuit is shown.  $U_{C1}$  is provided.

### IV. SIMULATION RESULTS

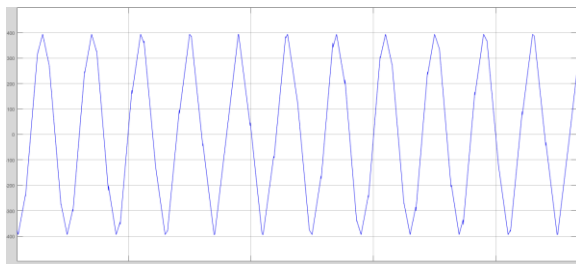
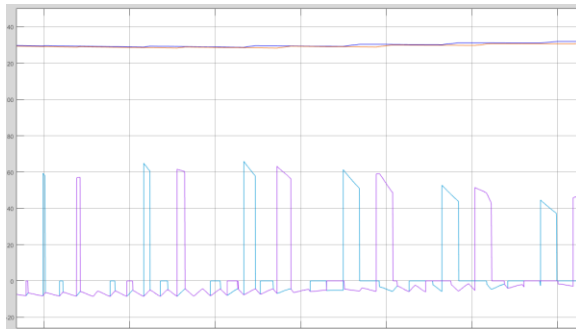
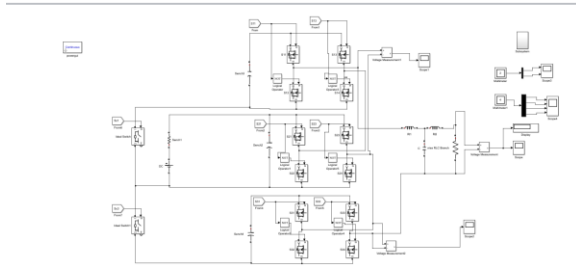

## V.CONCLUSION

A seven-level multilevel inverter using a single dc source is proposed which requires minimum number of switches with increased output levels with near-sinusoidal output waveform. Compared with the conventional multilevel inverters, it requires less number of components to achieve the same number of output levels. Due to the use of minimum switches in the structure, an optimized circuit with LCL filter layout and low THD is possible. The structure and principle of operation of the proposed topology is detailed in this paper. The proposed structure is applicable in renewable energy sources, industrial drive applications etc. The operations of the seven-level switched-Capacitor MLI verified by MATLAB software.

## FUTURE SCOPE

An active switch that operates at hard switching not only generates high switching losses but also introduces high voltage and current stresses on circuit components, resulting in poor efficiency

and low circuit stability the switching loss is theoretically proportional to the switching frequency. Now that hard-switching operation has serious switching losses. Some soft-switching techniques which adopt active-clamp circuit or snubber circuit have been proposed. These soft-switching techniques have substantially eliminated the switching loss. However, these techniques need to use additional auxiliary switch, diode and reactive components to make the active switches turn on at zero-voltage.

## REFERENCES

- [1] S. Kouro, M. Malinowski, K. Gopakumar, J. Pou, L. G. Franquelo, B. Wu, J. Rodriguez, M. A. Perez, and J. I. Leon, "Recent advances and industrial applications of multilevel converters," *IEEE Trans. Ind. Electron.*, vol. 57, no. 8, pp. 2553–2580, Aug. 2010.
- [2] H. Abu-Rub, J. Holtz, J. Rodriguez, and G. Baoming, "Medium-voltage multilevel converters; state of the art, challenges, and requirements in industrial applications," *IEEE Trans. Ind. Electron.*, vol. 57, no. 8, pp. 2581–2596, Aug. 2010.
- [3] J. Dixon, J. Pereda, C. Castillo, and S. Bosch, "Asymmetrical multilevel inverter for traction drives using only one dc supply," *IEEE Trans. Veh. Technol.*, vol. 59, no. 8, pp. 3736–3743, Oct. 2010.
- [4] S. Lu, K. A. Corzine, and M. Ferdowsi, "A unique ultracapacitor direct integration scheme in multilevel motor drives for large vehicle propulsion," *IEEE Trans. Veh. Technol.*, vol. 56, no. 4, pp. 1506–1515, Jul. 2007.
- [5] J. Rodriguez, S. Bernet, P. K. Steimer, and I. E. Lizama, "A survey on neutral-point-clamped inverters," *IEEE Trans. Ind. Electron.*, vol. 57, no. 7, pp. 2219–2230, Jul. 2010.