

# Design and Simulation of Cuk Converter-Fed BLDC Motor Drive for PFC with Fuzzy Logic Controller

**\*G.SHRUTHI, \*\*MR.SRINIVAS SINGIRIKONDA**

\*PG Scholar, Dept of EEE,TKR College of Engineering & technology; Meerpet,sarooranagar (Dt); Telangana, India.

\*\*Assistant Professor, Dept of EEE,TKR College of Engineering & technology, Meerpet,sarooranagar; (Dt); Telangana, India.

[shruthisgadapa@gmail.com](mailto:shruthisgadapa@gmail.com)

[s.srinivas241@gmail.com](mailto:s.srinivas241@gmail.com)

## ABSTRACT-

This project presents a fuzzy based PFC CUK converter-fed BLDC motor drive has been proposed with improved power quality at the ac mains. The speed control of BLDC motor and PFC at ac mains has been achieved using a single voltage sensor. The switching losses in the VSI have been reduced by the use of fundamental frequency switching by electronically commutating the BLDC motor. Moreover, the speed of the BLDC motor has been controlled by controlling the dc link voltage of the VSI. Therefore, the BLDC motor is electronically commutated such that the VSI operates in fundamental frequency switching for reduced switching losses. Moreover, the bridgeless configuration of the Cuk converter offers low conduction losses due to partial elimination of diode bridge rectifier at the front end. The simulation results are presented by using Matlab/simulink platform.

**Index Terms**—Brushless dc (BLDC) motor, continuous conduction mode (CCM), Cuk converter, discontinuous conduction mode (DCM), power factor correction (PFC), power quality (PQ).

## I. INTRODUCTION

Brushless DC (BLDC) motors are recommended for many low and medium power drives applications because of their high efficiency, high flux density per unit volume, low maintenance requirement, low EMI problems, high ruggedness and a wide range of speed control. Due to these advantages, they find applications in numerous areas such as household application, transportation (hybrid vehicle), aerospace, heating, ventilation and air conditioning (HVAC), motion control and robotics, renewable energy application etc [1-2]. The BLDC motor is a three phase synchronous motor consisting of a stator having a three phase concentrated windings and a rotor having permanent magnets. It doesn't have mechanical brushes and commutator assembly, hence wear and tear of the brushes and sparking issues as in case of conventional DC machines are eliminated in BLDC motor and thus has low EMI problems [3]. This motor

is also referred as electronically commutated motor (ECM) since an electronic commutation based on the Hall-Effect rotor position signals is used rather than a mechanical commutation.

There is a requirement of an improved power quality as per the international power quality (PQ) standard IEC 61000-3-2 which recommends a high power factor (PF) and low total harmonic distortion (THD) of AC mains current for

Class-A applications (<600W, <16A) which includes many household equipment's. The conventional scheme of a BLDC motor fed by a diode bridge rectifier (DBR) and a high value of DC link capacitor draws a non-sinusoidal current, from AC mains which is rich in harmonics such that the THD of supply current is as high as 65%, which results in power factor as low as 0.8. These types of power quality indices can't comply with the international PQ

standards such as IEC 61000-3-2. Hence, single-phase power factor correction (PFC) converters are used to attain a unity power factor at AC mains. These converters have gained attention due to single stage requirement for DC link voltage control with unity power factor at AC mains. It also has low component count as compared to multistage converter and therefore offers reduced losses [4-6].

Conventional schemes of PFC converters fed BLDC motor drive utilize an approach of constant DC link voltage of the VSI and controlling the speed by controlling the duty ratio of high frequency pulse width modulation (PWM) signals. The losses of VSI in such type of configuration are considerable since switching losses depend on the square of switching frequency ( $P_{sw\_loss} \propto f_s^2$ ) [7-8]. Ozturk have proposed a boost PFC converter based direct torque controlled (DTC) BLDC motor drive. They have the disadvantages of using a complex control which requires large amount of sensors and higher end digital signal processor (DSP) for attaining a DTC operation with PFC at AC mains. Hence, this scheme is not suited for low cost applications. Ho have proposed an active power factor correction (APFC) scheme which uses a PWM switching of VSI and hence has high switching losses. Wu have proposed a cascaded buck-boost converter fed BLDC motor drive, which utilizes two switches for PFC operation. This offers high switching losses in the front end converter due to doubles witch and reduces the efficiency of overall system [9-10].

This reduces the switching losses in VSI as a result of fundamental switching frequency operation for the electronic commutation of the BLDC motor and to the variation of the speed by controlling the voltage at the dc bus of VSI. For further improvement in efficiency, bridgeless (BL) converters are employed which permit the elimination of DBR in the front end

[11]. A buck-boost converter configuration is most effective among various BL converter topologies for applications requiring a wide selection of dc link voltage control (i.e., bucking and boosting mode). Jang and Jovanović and Huber et al. have presented BL buck and boost converters, respectively. These may provide the voltage buck or voltage boost which limits the operating selection of dc link voltage control. Wei et al. have proposed a BL buck-boost converter but use three switches which will be not a cost-effective solution [12]. A fresh group of BL SEPIC and Cuk converters has been reported in the literature but takes a large quantity of components and has losses connected with it.

## II. SYSTEM CONFIGURATION

Figs.1 and .2 show the PFC Cuk converter based VSI fed BLDC motor drive using a current multiplier and a voltage follower approach respectively.

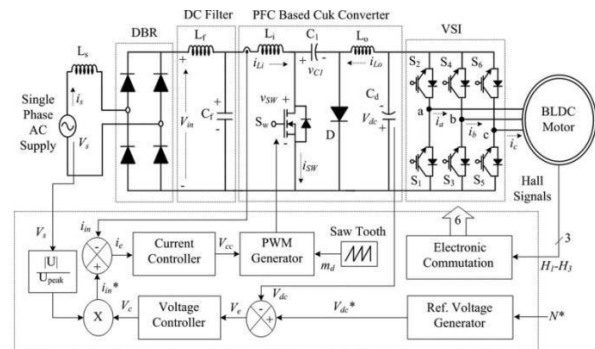

Fig. 1. BLDC motor drive fed by a PFC Cuk converter using a current multiplier approach. A high frequency metal oxide semiconductor field effect transistor (MOSFET) is used in Cuk converter for PFC and voltage control whereas insulated gate bipolar transistor's (IGBT) are used in the VSI for its low frequency operation. BLDC motor is commutated electronically to operate the IGBT's of VSI in fundamental frequency

switching mode to reduce its switching losses [13-14]. The PFC Cuk converter operating in CCM using a current multiplier approach is shown in Fig.1 i.e. the current flowing in the input and output inductors ( $L$   $L_o$ ), and the voltage across the intermediate capacitor ( $C_1$ ) remains continuous in a switching period. Whereas, Fig.2 shows a Cuk converter fed BLDC motor drive operating in DCM using a voltage follower Approach. The current flowing in either of the input or output inductor ( $L_i$  and  $L_o$ ) or the voltage across the intermediate capacitor ( $C_1$ ) become discontinuous in a switching period for a PFC Cuk converter operating in DCM. A Cuk converter is designed to operate in all three discontinuous conduction modes and a continuous conduction mode of operation and its performance is evaluated for a wide voltage control with unity power factor at AC mains [15].

### III. OPERATION OF CUK CONVERTER IN DIFFERENT MODES

The operation of Cuk converter is studied in four different modes of CCM and DCM. In CCM, the current in inductors ( $L_i$  and  $L_o$ ) and voltage across intermediate capacitor  $C_1$  remain continuous in a switching period. Moreover, the DCM operation is further classified into two broad categories of discontinuous inductor current mode (DICM) and discontinuous capacitor voltage mode (DCVM). In DICM, the current flowing in inductor  $L_i$  or  $L_o$  becomes discontinuous in their respective modes of operation. While in DCVM operation, the voltage appearing across the intermediate capacitor  $C_1$  becomes discontinuous in a switching period. Different modes for operation of CCM and DCM are discussed as follows.

#### A. CCM Operation

The operation of Cuk converter in CCM is described as follows. Figs.3(a) and (b) show the operation of Cuk

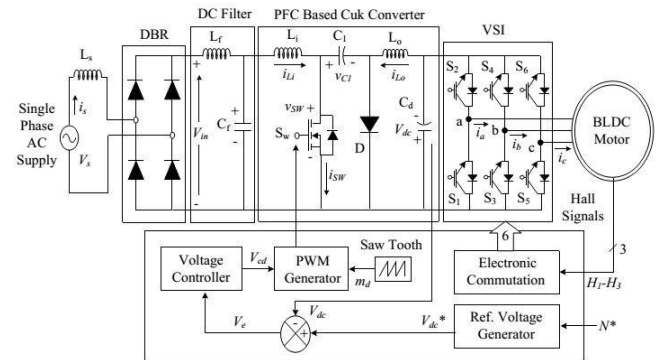

Fig 2. A BLDC motor drive fed by a PFC Cuk converter using a voltage follower approach.

Converter in two different intervals of a switching period and Fig.3(c) shows the associated waveforms in a complete switching period.

**Interval I:** When switch  $S_{sw}$  turned on, inductor  $L_i$  stores energy while capacitor  $C_1$  discharges and transfers its energy to DC link capacitor  $C_d$  as shown in Fig.3(a). Input inductor current  $i_{L_i}$  increases while the voltage across the intermediate capacitor  $V_{C_1}$  decreases as shown in Fig.3(c).

**Interval II:** When switch  $S_{sw}$  turned off, then the energy stored in inductor  $L_o$  is transferred to DC link capacitor  $C_d$ , and inductor  $L_i$  transfers its stored energy to the intermediate capacitor  $C_1$  as shown in Fig.3(b). The designed values of  $L_i$ ,  $L_o$  and  $C_1$  are large enough such that a finite amount of energy is always stored in these components in a switching period.

#### B. DICM ( $L_i$ ) Operation

The operation of Cuk converter in DICM ( $L_i$ ) is described as follows. Figs.4(a)-(c) show the operation of Cuk converter in three different intervals of a switching period and Fig.4 (d) shows the associated waveforms in a switching period.

**Interval I:** When switch  $S_{wm}$  turned on, inductor  $L_i$  stores energy while capacitor  $C_1$  discharges through Switch  $S_w$  to transfer its energy to the DC link capacitor  $C_d$  as shown in Fig.4 (a). Input inductor current  $i_{Li}$  increases while the voltage across the capacitor  $C_1$  decreases as shown in Fig.4 (d).

**Interval II:** When switch  $S_{wm}$  turned off, then the energy stored in inductor  $L_i$  is transferred to intermediate capacitor  $C_1$  via diode  $D$ , till it is completely discharged to enter DCM operation.

**Interval III:** During this interval, no energy is left in input inductor  $L_i$ , hence current  $I_{L_i}$  becomes zero. Moreover, inductor cooperates in continuous conduction to transfer its energy to DC link capacitor  $C_d$ .

### C. DICM ( $L_o$ ) Operation

The operation of Cuk converter in DICM ( $L_o$ ) is described as follows. Figs.5(a)-(c) show the operation of Cuk converter in three different intervals of a switching period and Fig.5(d) shows the associated waveforms in a switching period.

**Interval I:** As shown in Fig.5(a), when switch  $S_{wm}$  turned on, inductor  $L$  stores energy while capacitor  $C_1$  discharges through switch  $S_w$  to transfer its energy to the DC link capacitor  $C_d$ .

**Interval II:** When switch  $S_{wm}$  turned off, then the energy stored in inductor  $L_i$  and  $L_o$  is transferred to intermediate capacitor  $C_1$  and DC link capacitor  $C_d$  respectively.

**Interval III:** In this mode of operation, the output inductor  $L_o$  is completely discharged hence its current  $i_{L_o}$  becomes zero. An inductor  $L_i$  operates in continuous conduction to transfer its energy to the intermediate capacitor  $C_1$  via diode  $D$ .

### D. DCVM ( $C_1$ ) Operation

The operation of Cuk converter in DCVM ( $C_1$ ) is described as follows. Figs.6(a)-(c) show the operation of Cuk converter in three different intervals of a switching period and Fig. 6(d)

shows the associated waveforms in a switching period.

**Interval I:** When switch  $S_{wm}$  turned on as shown in Fig.6 inductor  $L_i$  stores energy while capacitor  $C_1$  discharges through switch  $S_w$  to transfer its energy to the DC link capacitor  $C_d$  as shown in Fig.6 (d).

**Interval II:** The switch is in conduction state but intermediate capacitor  $C_1$  is completely discharged, hence the voltage across it becomes zero. Output inductor  $L_o$  continues to supply energy to the DC link capacitor.

**Interval III:** As the switch  $S_w$  is turned off, input inductor  $L_i$  starts charging the intermediate capacitor, while the output inductor  $L_o$  continues to operate in continuous conduction and supplies energy to the DC link capacitor.

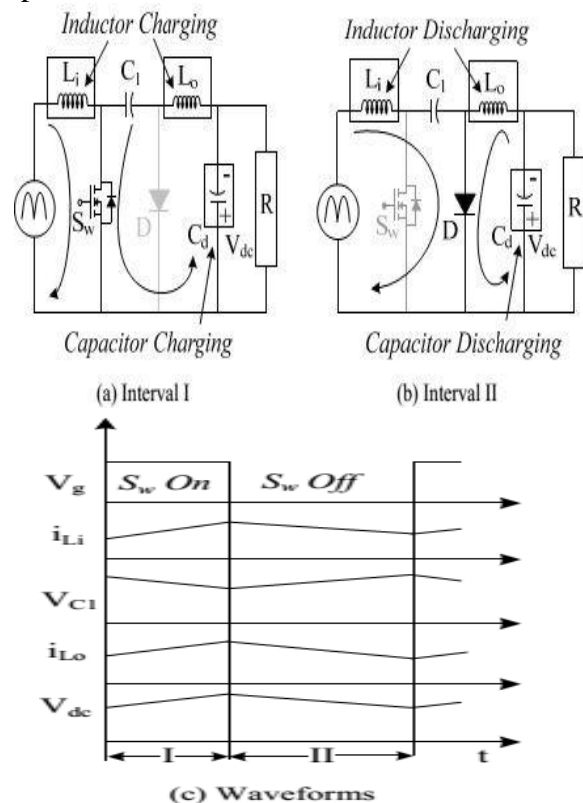

Fig.3. Operation of Cuk converter in CCM during (a-b) different intervals of switching period and (c) the associated waveforms.

#### IV. DESIGN OF A PFC CUK CONVERTER

A PFC based Cuk converter fed BLDC motor drive is designed for DC link voltage control of VSI with power factor correction at the AC mains. The Cuk converter is designed for a CCM and three different DCMs. In DCM, any one of the energy storing elements  $L_i$ ,  $L_o$  or  $C_1$  are allowed to operate in discontinuous mode whereas in CCM, all these three parameters operate in continuous conduction. The design and selection criterion of these three parameters is discussed in the following section. The input voltage  $V_s$  applied to the DBR is given as,

$$v_s(t) = V_m \sin(2\pi f_L t) = 220\sqrt{2} \sin(314t) \text{ V} \quad (1)$$

Where  $V_m$  is the peak input voltage (i.e.  $\sqrt{2}V_s$ ,  $V_s$  is the rms value of supply voltage),  $f_L$  is the line frequency i.e. 50 Hz. The instantaneous voltage appearing after the DBR is as,

$$V_{in}(t) = |V_m \sin(\omega t)| = |220\sqrt{2} \sin(314t)| \text{ V} \quad (2)$$

Where  $||$  represents the modulus function. The output voltage,  $V_{dc}$  of Cuk converter is given as

$$V_{dc} = \frac{D}{(1-D)} V_{in}(t) \quad (3)$$

Where  $D$  represents the duty ratio. The instantaneous value of duty ratio,  $D(t)$  depends on the Input voltage appearing after DBR,  $V_{in}(t)$  and the required DC link voltage,  $V_{dc}$ .

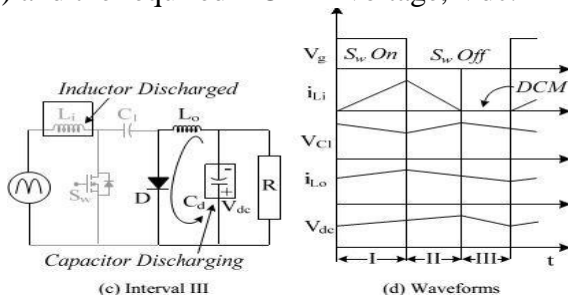

Fig.4. Operation of Cuk converter in DICM ( $L_i$ ) during (a-c) different Intervals of switching period and (d) the associated waveforms

Hence the instantaneous duty ratio,  $D(t)$  is obtained by substituting (2) in (3) and rearranging it as,

$$D(t) = \frac{V_{dc}}{V_{in}(t) + V_{dc}} = \frac{V_{dc}}{|V_m \sin(\omega t)| + V_{dc}} \quad (4)$$

The Cuk converter is designed to operate from a minimum DC voltage of 40V ( $V_{dc \text{ min}}$ ) to a maximum DC link voltage of 200V ( $V_{dc \text{ max}}$ ). The PFC converter of maximum power rating of 350W ( $P_{\text{max}}$ ) is designed for a BLDC motor of 251W ( $P_m$ ) (full specifications given in Table I) and the switching frequency ( $f_S$ ) is taken as 20kHz. Since the speed of the BLDC motor is controlled by varying the DC link voltage of the VSI, hence the instantaneous power,  $P_i$  at any DC link voltage ( $V_{dc}$ ) can be taken as linear function of  $V_{dc}$ . Hence for a minimum value of DC link voltage as 40V, the minimum power is calculated as 70W.

##### A. Design of $L_i$

For Continuous or Discontinuous Current Conduction the critical value of input inductor  $L_{ic}$  is expressed as

$$\begin{aligned} L_{ic} &= \frac{V_{in}(t)D(t)}{2I_{in}(t)f_S} = \frac{R_{in}D(t)}{2f_S} = \left(\frac{V_s^2}{P_i}\right) \frac{D(t)}{2f_S} \\ &= \frac{1}{2f_S} \left(\frac{V_s^2}{P_i}\right) \left(\frac{V_{dc}}{V_{in}(t) + V_{dc}}\right) \end{aligned} \quad (5)$$

Hence the critical value of input side inductor is directly proportional to the rms value of supply voltage; therefore the worst case design occurs for the minimum value of supply voltage (i.e.  $V_s = V_{s \text{ min}} = 85\text{V}$ ). Now the critical value of input inductor at the maximum DC link voltages of 200V at the peak value of supply voltage (i.e.  $\sqrt{2}V_{s \text{ min}}$ ) is calculated as,

$$L_{ic200} = \frac{1}{2f_S} \left(\frac{V_{s \text{ min}}^2}{P_{\text{max}}}\right) \left(\frac{V_{dc \text{ max}}}{\sqrt{2}V_{s \text{ min}} + V_{dc \text{ max}}}\right) \quad (6)$$

And the critical value of input inductor at the minimum value of DC link voltages of

40V at the peak value of supply voltage is calculated as

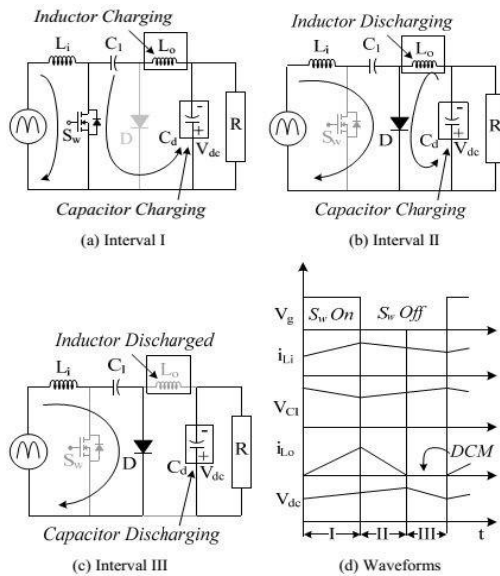

Fig.5. Operation of Cuk converter in DICM (Lo) during (a-c) different intervals of switching period and (d) the associated waveforms.

$$L_{ic40} = \frac{1}{2f_s} \left( \frac{V_{smin}^2}{P_{min}} \right) \left( \frac{V_{dcmin}}{\sqrt{2}V_{smin} + V_{dcmin}} \right) \quad (7)$$

Hence the value of critical input inductance is obtained lower at maximum DC link voltage. Therefore, the critical value of input inductor is selected lower than Lic200. The Performance of the Cuk converter feeding BLDC motor drive is analyzed for different values of input side inductor i.e.

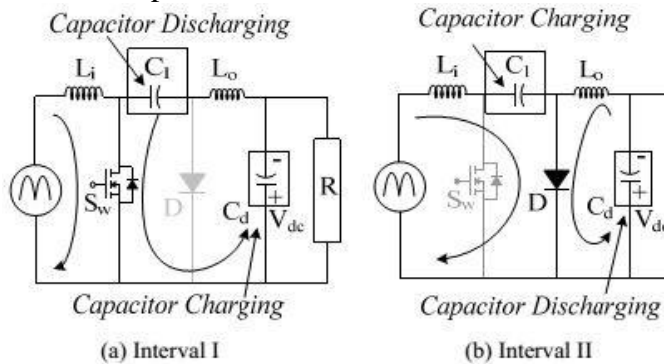
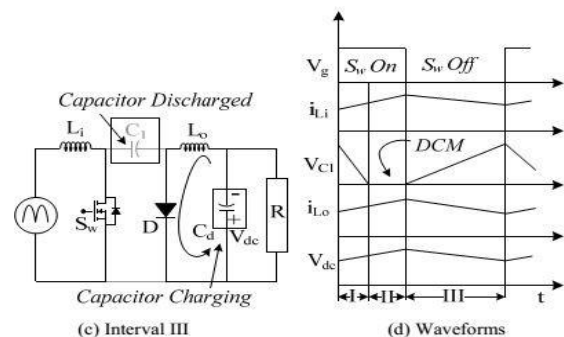

Fig.6. Operation of Cuk converter in DCVM (C1) during (a-c) different intervals of switching period and (d) the associated waveforms

## V. INTRODUCTION TO FUZZY LOGIC CONTROLLER

A new language was developed to describe the fuzzy properties of reality, which are very difficult and sometime even impossible to be described using conventional methods. Fuzzy set theory has been widely used in the control area with some application to dc-to-dc converter system. A simple fuzzy logic control is built up by a group of rules based on the human knowledge of system behavior. Matlab/Simulink simulation model is built to study the dynamic behavior of dc-to-dc converter and performance of proposed controllers. Furthermore, design of fuzzy logic controller can provide desirable both small signal and large signal dynamic performance at same time, which is not possible with linear control technique. Thus, fuzzy logic controller has been potential ability to improve the robustness of dc-to-dc converters.

The basic scheme of a fuzzy logic controller is shown in Fig 5 and consists of four principal components such as: a fuzzy fiction interface, which converts input data into suitable linguistic values; a knowledge base, which consists of a data base with the necessary



linguistic definitions and the control rule set; a decision-making logic which, simulating a human decision process, infer the fuzzy control action from the knowledge of the control rules and linguistic variable definitions; a defuzzification interface which yields non fuzzy control action from an inferred fuzzy control action [10].

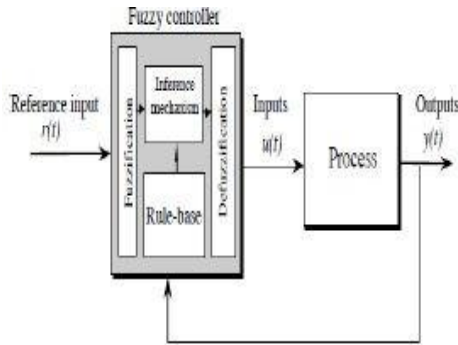

Fig 7 General structure of the fuzzy logic controller on closed-loop system

The fuzzy control systems are based on expert knowledge that converts the human linguistic concepts into an automatic control strategy without any complicated mathematical model [10][11]. Simulation is performed in buck converter to verify the proposed fuzzy logic controllers.

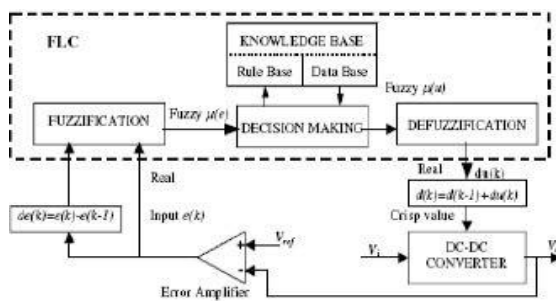

Fig 8 Block diagram of the Fuzzy Logic Controller (FLC) for dc-dc converters

**a) Fuzzy Logic Membership Functions:**

The dc-dc converter is a nonlinear function of the duty cycle because of the small signal

model and its control method was applied to the control of boost converters. Fuzzy controllers do not require an exact mathematical model. Instead, they are designed based on general knowledge of the plant. Fuzzy controllers are designed to adapt to varying operating points. Fuzzy Logic Controller is designed to control the output of boost dc-dc converter using Mamdani style fuzzy inference system. Two input variables, error (e) and change of error (de) are used in this fuzzy logic system. The single output variable (u) is duty cycle of PWM output.

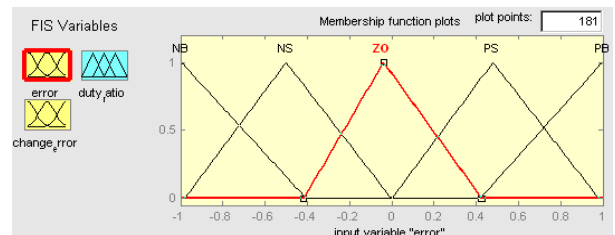

Fig 9 The Membership Function plots of error

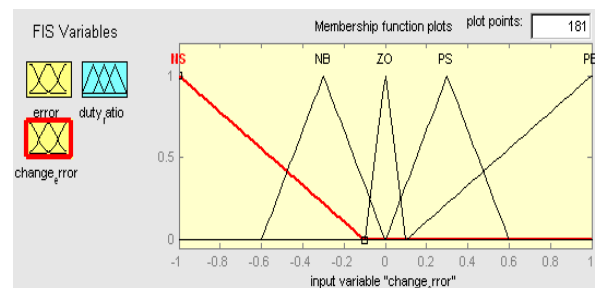

Fig 10 The Membership Function plots of change error

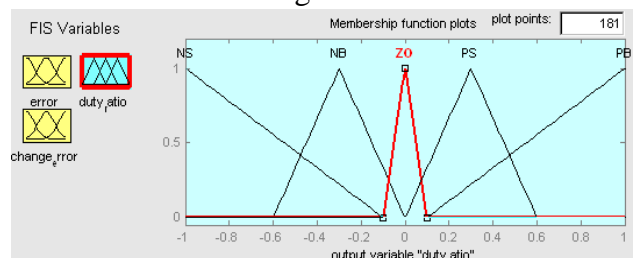

Fig 11 The Membership Function plots of duty ratio

**b) Fuzzy Logic Rules:**

The objective of this dissertation is to control the output voltage of the boost converter. The error and change of error of the output voltage will be the inputs of fuzzy logic controller. These 2 inputs are divided into five groups; NB: Negative Big, NS: Negative Small, ZO: Zero Area, PS: Positive small and PB: Positive Big and its parameter [10][11]. These fuzzy control rules for error and change of error can be referred in the table that is shown in Table II as per below:

Table II

Table rules for error and change of error

(e) (de)	NB	NS	ZO	PS	PB
NB	NB	NB	NB	NS	ZO
NS	NB	NB	NS	ZO	PS
ZO	NB	NS	ZO	PS	PB
PS	NS	ZO	PS	PB	PB
PB	ZO	PS	PB	PB	PB

**VI. MATLAB/SIMULATION RESULTS**

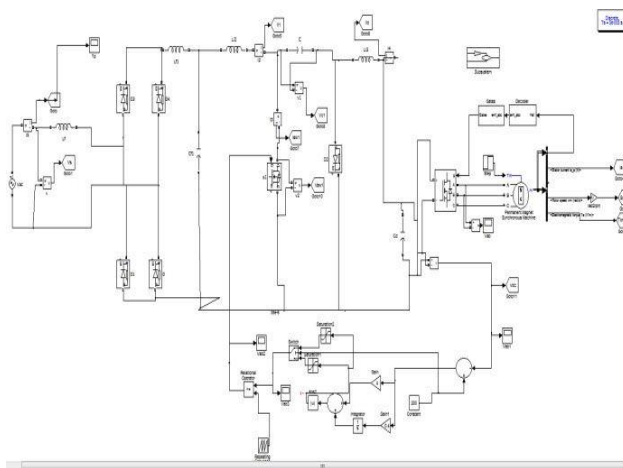

Fig 12 Simulation model of BLDC motor drive fed by a PFC Cuk converter using a multiplier approach

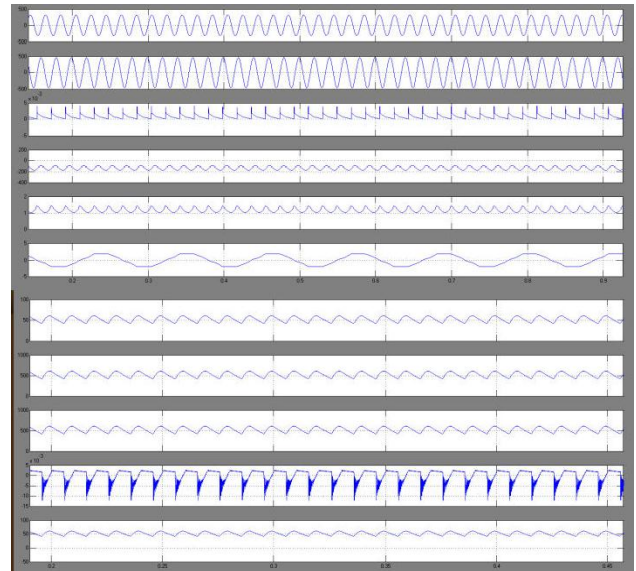

Fig 13 Simulation waveform of the BLDC motor drive with the Cuk converter operating in the CCM

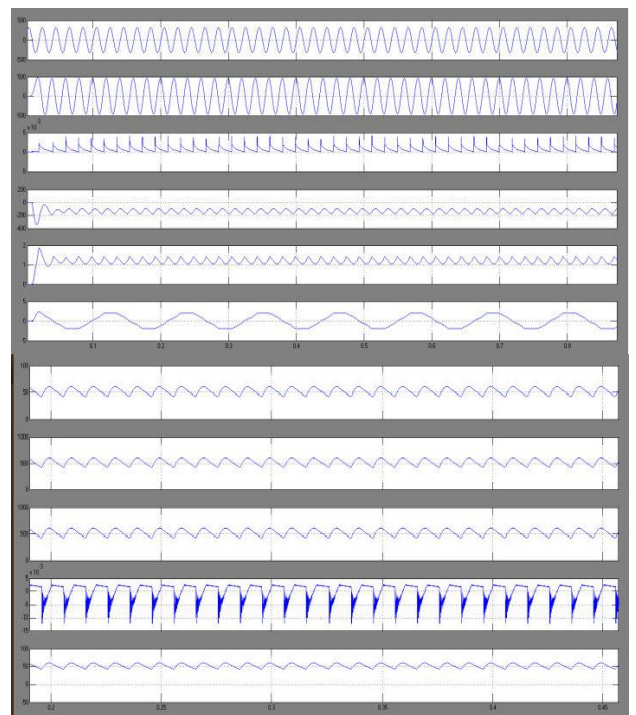

Fig 14 Simulated performance of the BLDC motor drive with the Cuk converter operating in the DICM



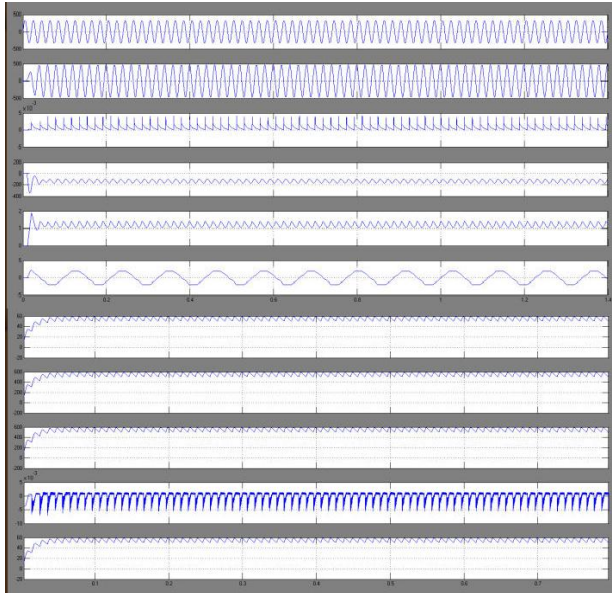

Fig 15 Simulated performance of the BLDC motor drive with the Cuk converter operating in the DICM

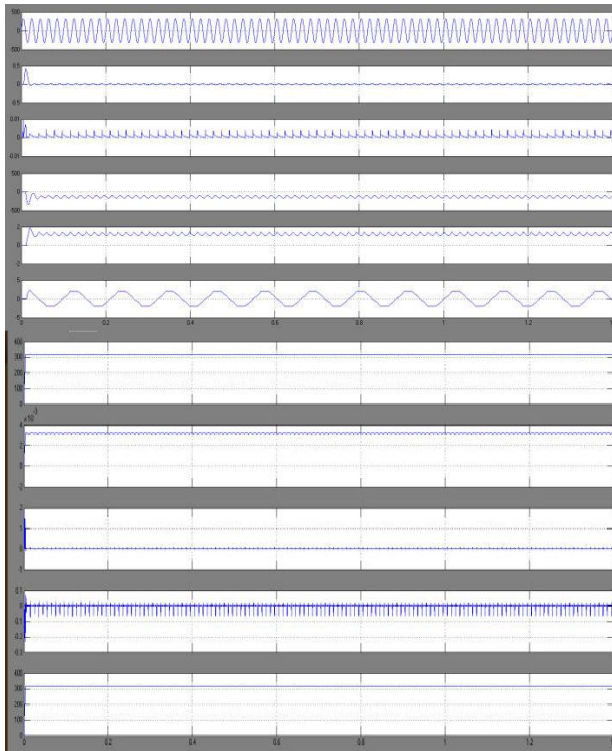

Fig 16 Simulated performance of the BLDC motor drive with the Cuk converter operating in the DCVM

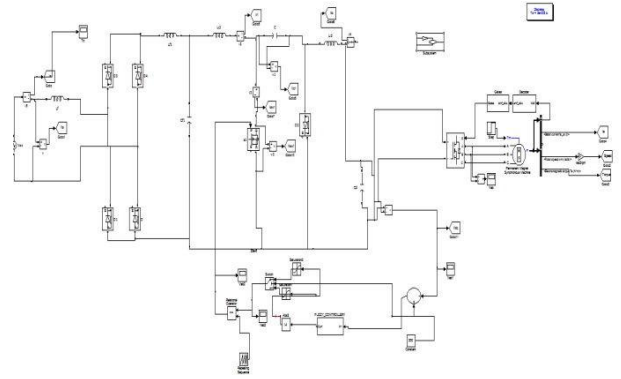

Fig 17 Simulation model of fuzzy based BLDC motor drive fed by a PFC Cuk converter

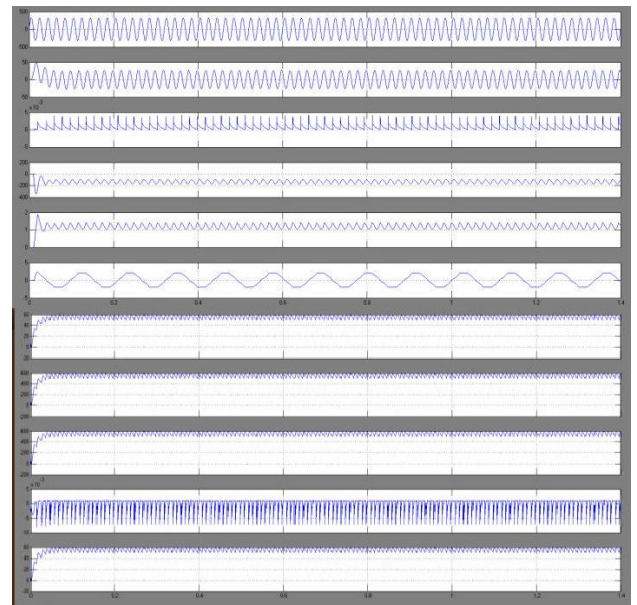

Fig 18 Simulation waveform of the BLDC motor drive with the Cuk converter operating in the CCM

### V.CONCLUSION

A new speed control strategy for a BLDC using the reference speed as an equivalent voltage at dc link has been simulated .A Cuk PFC converter is employed with fuzzy controller .The speed of the BLDC has been found to be proportional to the dc link voltage; thereby a smooth speed control is observed while

controlling the dc link voltage .The PFC cuk converter has ensured near unity PF in a wide range of speed and the input ac voltage.A detailed comparison of all modes of operation has been presented on the basis of feasibility in design and the cost constraint in the development of such drive for low power applications. Finally, a best suited mode of Cuk converter with output inductor current operating in DICM has been selected for experimental verifications. The proposed drive system has shown satisfactory results in all aspects and is a recommended solution for low power BLDC motor drives.

### REFERENCES

- [1] J. F. Gieras and M. Wing, Permanent Magnet Motor Technology—Design and Application. New York, NY, USA: Marcel Dekker, Inc, 2002.
- [2] C. L. Xia, Permanent Magnet Brushless DC Motor Drives and Controls. Beijing, China: Wiley, 2012.
- [3] Y. Chen, C. Chiu, Y. Jhang, Z. Tang, and R. Liang, “A driver for the singlephase brushless DC fan motor with hybrid winding structure,” *IEEE Trans. Ind. Electron.*, vol. 60, no. 10, pp. 4369–4375, Oct. 2013.
- [4] S. Nikam, V. Rallabandi, and B. Fernandes, “A high torque density permanent magnet free motor for in-wheel electric vehicle application,” *IEEE Trans. Ind. Appl.*, vol. 48, no. 6, pp. 2287–2295, Nov./Dec. 2012.
- [5] X. Huang, A. Goodman, C. Gerada, Y. Fang, and Q. Lu, “A single sided matrix converter drive for a brushless DC motor in aerospace applications,” *IEEE Trans. Ind. Electron.*, vol. 59, no. 9, pp. 3542–3552, Sep. 2012.
- [6] W. Cui, Y. Gong, and M. H. Xu, “A permanent magnet brushless DC motor with bifilar winding for automotive engine cooling application,” *IEEE Trans. Magn.*, vol. 48, no. 11, pp. 3348–3351, Nov. 2012.
- [7] C. C. Hwang, P. L. Li, C. T. Liu, and C. Chen, “Design and analysis of a brushless DC motor for applications in robotics,” *IET Elect. Power Appl.*, vol. 6, no. 7, pp. 385–389, Aug. 2012.
- [8] T. K. A. Brekken, H. M. Hapke, C. Stillinger, and J. Prudell, “Machines and drives comparison for low-power renewable energy and oscillating applications,” *IEEE Trans. Energy Convers.*, vol. 25, no. 4, pp. 1162–1170, Dec. 2010.
- [9] N. Milivojevic, M. Krishnamurthy, A. Emadi, and I. Stamenkovic, “Theory and implementation of a simple digital control strategy for brushless DC generators,” *IEEE Trans. Power Electron.*, vol. 26, no. 11, pp. 3345–3356, Nov. 2011.
- [10] Srinivas Singirikonda, Transient Stability of A.C Generator Controlled By Using Fuzzy Logic Controller *Int. Journal of Engineering Research and Applications* ISSN: 2248-9622, Vol. 4, Issue 3 (Version 1), March 2014, pp.389-395.
- [11] Srinivas Singirikonda, Ziegler-Nichols (Z-N) Based PID Plus Fuzzy Logic Control (FLC) For Speed Control of A Direct Field-Oriented Induction Motor (DFOIM) *Int. Journal of Engineering Research and Applications* ISSN: 2248-9622, Vol. 3, Issue 6, Nov-Dec 2013, pp.755-762.
- [12] J. R. Handershot and T. J. E Miller, Design of Brushless Permanent Magnet Motors. Oxford, U.K.: Clarendon Press, 2010.
- [13] T. J. Sokira and W. Jaffe, Brushless DC Motors: Electronics Commutation and Controls. Blue Ridge Summit, PA, USA: Tab Books, 1989.
- [14] H. A. Toliyat and S. Campbell, DSP-Based Electromechanical Motion Control. New York, NY, USA: CRC Press, 2004.
- [15] “Limits for harmonic current emissions (equipment input current  $\leq 16$  A per phase),” International Standard IEC 61000-3-2, 2000



[16] N. Mohan, T. M. Undeland, and W. P. Robbins, Power Electronics: Converters, Applications and Design. New York, NY, USA: Wiley, 2009.