

# Mitigation of Total Harmonic Distortion for UPQC Based DFIG System Using Various Controllers

Mrs.A.Lakshmi Durga & Mr.G.Jagadeesh

Assistant.Professor Department Of Electrical & Electronics Engineering, Dadi Institute Of Engineering And Technology, Jntuk; Anakapalle(Dt); A.P, India.

Assistant.Professor Department Of Electrical & Electronics Engineering, Dadi Institute Of Engineering And Technology, Jntuk; Anakapalle(Dt); A.P, India

[aldurga@diet.edu.in](mailto:aldurga@diet.edu.in) , [jagadeesh@diet.edu.in](mailto:jagadeesh@diet.edu.in)

**Abstract—** This paper describes the simulation of an interconnection of grid connected wind power system to analyzes the power quality problems such as voltage sag, swell, flickers, harmonics, etc. by providing the unified power quality conditioner (UPQC). The hybrid fuzzy logic controller is proposed to improve the performance of UPQC to diminish voltage sag, swell and also load current harmonics. The conventional PI control, fuzzy logic control based UPQC can completely mitigates voltage sag, swell but the load current harmonics obtained is not in acceptable limits. The hybrid fuzzy logic controlled UPQC which mitigates the voltage sag, swell and also reduces the load current harmonics/improves the power quality. The performance of hybrid fuzzy logic controlled UPQC is compared with conventional PI and FLC based UPQC from simulation results using MATLAB/SIMULINK.

**Index Terms—**voltage sag, current harmonics, Doubly Fed Induction Generator (DFIG), Unified Power Quality Conditioner (UPQC), Power Quality (PQ).

## I.INTRODUCTION

Power Quality (PQ) related issues are of most concern now days. These power quality issues can occurs either from source side or from load side. Source side power quality problems can be given as Voltage sags, Voltage variations, Interruptions Swells, Brownouts, Blackouts, Voltage imbalance. The power quality problems arise from the load side due to widespread use of electronic equipment, such as information technology equipment, power electronics such as adjustable speed drives (ASD), programmable logic controllers (PLC), energy efficient lighting, led to a complete change of electric loads nature. These loads are simultaneously the major causes and the major victims of power quality problems. Due to their non-linearity, all these loads cause disturbances in the voltage waveform. Custom power devices have been proposed for enhancing the quality and reliability of electrical power. Unified Power Quality Conditioner (UPQC) is a versatile custom power device which consists of two inverters connected back-to-back and deals with both load current and supply voltage imperfections. UPQC can simultaneously perform as

shunt and series active power filters. The series part of the UPQC is known as Dynamic Voltage Restorer (DVR). It

is used to maintain balanced, distortion free nominal voltage at the load. The shunt part of the UPQC is known as Distribution Static Compensator (DSTATCOM) and it is used to compensate load reactive power, harmonics and balance the load currents thereby making the source current balanced and distortion free with unity power factor [1-3].

But DVR doesn't take care of load current harmonics, which when untreated, results in low power factor, leads to voltage notch and reduced consumption of the distribution system. The device STATCOM is widely used for the eradication of load current harmonics in addition to the contribution of reactive power control [4], but it doesn't take care of voltage related problems. UPQC replaces the functions of both devices by mitigating both voltage sag and load current harmonics, thus replacing the functions of two devices DVR and STATCOM [5].

The choice of suitable controller plays a vital role to improve the performance of UPQC. In conventional PI controller, proportional and integral gains are chosen heuristically and requires precise linear mathematical model of the system which makes it difficult to obtain under parameter variations and non-linear load disturbances. The fuzzy logic controller is proposed works with linguistic variables and it doesn't need any mathematical modeling which is best suited for nonlinear loads [6]. In the proposed work, the Power Quality problems namely voltage sag and current harmonics are simulated and analyzed in the grid connected wind power system. The FLC based UPQC is implemented for effective and efficient mitigation of both voltage sag and current harmonics and its performance is validated by comparing the simulation results with conventional PI controlled UPQC [7-8].The performance of unified power quality conditioner is mainly depends on how quickly and accurately compensation signals are derived. The control

strategies used here are based on PI Controller and fuzzy logic controller [9]. The PI control based techniques are simple and reasonably effective. Further, the control of UPQC based on the conventional PI control is prone to severe dynamic interaction between active and reactive power flows [10]. The conventional PI controller may be replaced by a Fuzzy Logic Controller (FLC) for better response [11]. The beauty of fuzzy logic controller over PI controller is that it does not need an accurate mathematical model and can handle nonlinearity, work with imprecise input and may be more robust than the conventional PI controller. Recently fuzzy logic controller has generated a great deal of Interest in various applications and has been introduced in the power systems and power electronics field [12]. The performance of the proposed system is demonstrated through simulated waveforms using Sim Power Systems (SPS) MATLAB/SIMULINK environment.

## II. GRID INTEGRATED DFIG BASED WIND POWERSYSTEM - POWER QUALITY ISSUES AND THEIR IMPACTS

Power Quality (PQ) is used to describe electric power that drives an electrical load and the load's ability to function properly. Power Quality determines the fitness of electric power to consumer devices.

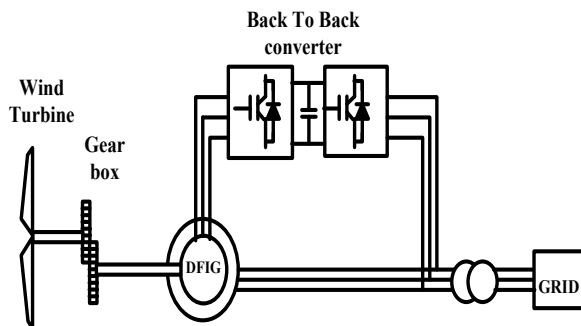

Fig.1. Grid connected DFIG based wind power system.

Wind power is fast becoming one of the leading renewable energy sources worldwide. Most of the wind farms uses fixed speed wind turbine, its performance relies on the characteristics of mechanical sub circuits, every time a gust of wind strikes the turbine, a fast and strong variation of electrical output power can be observed, as the response time of mechanical sub-circuits is in the range of 10 milliseconds. These load variations necessitates a stiff power grid and sturdy mechanical design to absorb high mechanical stresses. This approach leads to expensive mechanical construction, so that in order to overcome the above issues, now-a-days DFIG based variable speed wind turbine comes into picture which is benefitted with the following pros:

- Cost effective
- Simple means of pitch control
- Reduced mechanical stresses
- Dynamic compensation of torque pulsations
- Improved Quality of Power
- Reduced acoustic noise

The schematic diagram of interconnection of Grid with DFIG based wind power system is shown in Fig.1. The stator of DFIG is used to supply power directly to the grid, while the rotor supplies power to the grid via power electronic converter. As the back to back converter is connected only to the rotor, the converter costs only 25% of the total system power which improves entire system efficiency to a greater extent. While integrating electric grid with wind power system, owing to the stochastic nature of the wind, the quality of power from the generator output gets affected. If a huge proportion of the grid load is supplied by wind turbines, the output deviations owing to wind speed alternations incorporate voltage variations, harmonics and flicker. The origin of voltage variations such as voltage sag and swell is due to wind velocity, generator torque and switching of wind turbine generator. Harmonics is one of the severe problems in grid connected wind power system. As the consequences faced by voltage sag and harmonics are dominant and leads to degradation of PQ at the consumer's terminal, this paper concentrates on alleviating these two PQ problems. The foremost impacts of the PQ problems are

- Malfunction of equipment's such as adjustable speed drives, microprocessor based control system and Programmable Logic Controller.
- Tripping of protection devices.
- Stoppage and damage of sensitive equipment's like personal computers, industrial drives etc.,

The Standards provided by IEEE for individual customers and utilities for improving PQ is shown below:

- IEEE Standard 519 issued in 1981, suggests voltage distortion < 5% on power lines below 69 kV.
- ANSI/IEEE Standard C57.12.00 and C57.12.01 confines the current distortion to 5% at full load in supply transformer.

In order to keep PQ within bounds, there is a need PQ Enhancement. For this custom power devices plays a vital role for the purpose of supplying required level of PQ thus make the grid connected wind power system free from PQ problems.

## III. UNIFIED POWER QUALITY CONDITIONER

UPQC is a custom power device which is responsible for the alleviation PQ disturbances in both supply and load side. The schematic diagram of UPQC is shown in Fig.2.

UPQC consists of two Voltage Source Inverters (VSI) series and shunt, tied back to back with each other sharing a common dc link. The shunt inverter is controlled in current control mode such that it delivers a current which is equal to the set value of the reference current as governed by the UPQC control algorithm and also to maintain the dc bus voltage at a set reference value.

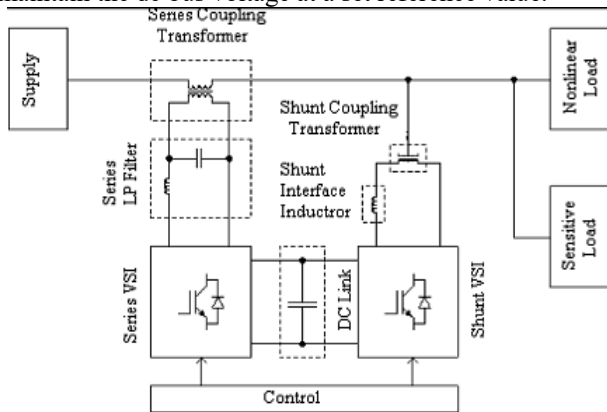

Fig.2. Schematic diagram of Unified Power Quality Conditioner.

In order to mitigate harmonics commenced by nonlinear load, the shunt inverter injects a current as governed by following equation:

$$I_{sh}(\omega t) = i_s^*(\omega t) - i_L(\omega t) \quad (1)$$

Where,  $i_{sh}$  represents the shunt VSI current,  $i_s^*$  represents reference supply current, and  $i_L$  represents load current respectively.

The series inverter of UPQC is employed in voltage control mode as it supplies and injects voltage in series with line to realize a sinusoidal, distortion free voltage at the load terminal. The voltage injected by series VSI is depicted by the following equation:

$$V_{sr}(\omega t) = V_L^*(\omega t) - V_s(\omega t) \quad (2)$$

Where,  $V_{sr}$  represents the series inverter injected voltage,  $V_L^*$  represents reference load voltage, and  $V_s$  represents actual supply voltage respectively. UPQC is responsible for mitigating both current and voltage related issues and also has the subsequent facilities:

- It eradicates the harmonics in the supply current, thus enlarging utility current quality for nonlinear loads.
- UPQC also supports VAR requirement of the load, so that the supply voltage and current are forever in phase. As a consequence no additional power factor correction equipment is essential.
- UPQC maintains load end voltage at the rated value even in the existence of supply side disturbances.

- The voltage injected by UPQC to keep the load voltage at the desired value is taken from the same dc link, thus no extra dc link voltage support is involved for the series compensator.

#### IV. PROPOSED METHODOLOGY

The proposed work in the power grid is interconnected with Doubly Fed Induction Generator (DFIG) based wind Turbine and is synchronized in terms of voltage and frequency. The wind speed is kept as 15m/s which are regarded as nominal value which may diverge from 8 to 15 m/s owing to fluctuations. The PQ problems voltage sag is simulated by creating three phase to ground fault and the load current harmonics are simulated by connecting Diode bridge rectifier load in the proposed grid connected wind power system. For PQ enhancement, UPQC is designed for the above mentioned problems and the proposed control strategy using FLC is implemented for the generation of both reference voltage for series inverter and the reference current for shunt inverter which provides an effective mitigation of both supply side and also loads side disturbances, thus keeps the PQ in a grid connected wind power system as per IEEE norms. The effectiveness of the proposed FLC based UPQC by comparing the simulation results with the conventional PI controller based UPQC.

#### V. CONTROL STRATEGY

In this work the performance of UPQC is enhanced by developing a novel control strategy using FLC. The benefits of FLC over the conventional controller are that FLC even works without a perfect mathematical model. Also FLC is capable of handling nonlinearity and is more robust compared to conventional PI controller which also improves the performance of UPQC. The control strategy used in this work is described below.

##### A. CONVENTIONAL PI CONTROL STRATEGY

In this control strategy, both shunt and series APF in UPQC is controlled with conventional PI controller as shown in fig.3. And fig.4. The gain values P and I are chosen as  $K_p=0.1$  and  $K_i=2$  using trial and error method. In series APF, the faulted sag voltage is compared with the reference voltage. The error voltage is processed through PI controller and its output is converted to three phase through unit vector generation, then it is fed into Pulse Width Modulation (PWM) generator to provide gate pulses to Series APF such that this can be able to inject the required voltage for the mitigation of voltage sag.

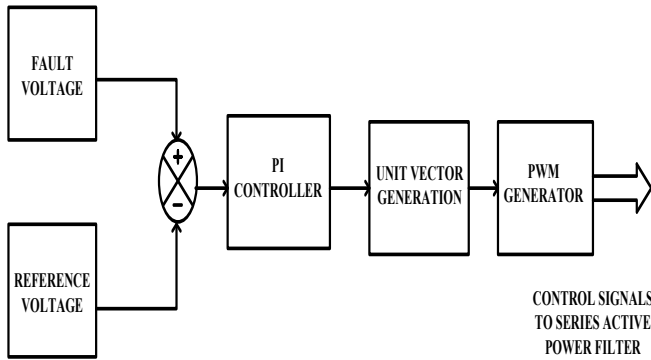

Fig.3. Control strategy for Series APF of UPQC.

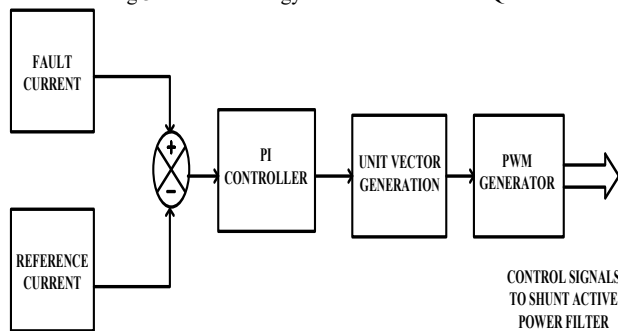

Fig.4. Control strategy for Shunt APF of UPQC.

In Shunt APF, the harmonic load current is compared with the reference current and the error is processed through PI controller. Its output is converted to three phase and it is fed into PWM generator for providing gate pulses to Shunt APF which is capable of mitigating load current harmonics.

### B. Fuzzy Logic Controller

FLC is one of the most successful operations of fuzzy set theory. Its chief aspects are the exploitation of linguistic variables rather than numerical variables. FL control technique relies on human potential to figure out the systems behavior and is constructed on quality control rules. FL affords a simple way to arrive at a definite conclusion based upon blurred, ambiguous, imprecise, noisy, or missing input data. The basic structure of an FLC is represented in Fig.6.

- A Fuzzification interface alters input data into suitable linguistic values.
- A Knowledge Base which comprises of a data base along with the essential linguistic definitions and control rule set.
- A Decision Making Logic which collects the fuzzy control action from the information of the control rules and the linguistic variable descriptions.
- A Defuzzification interface which surrenders a non fuzzy control action from an inferred fuzzy control action.

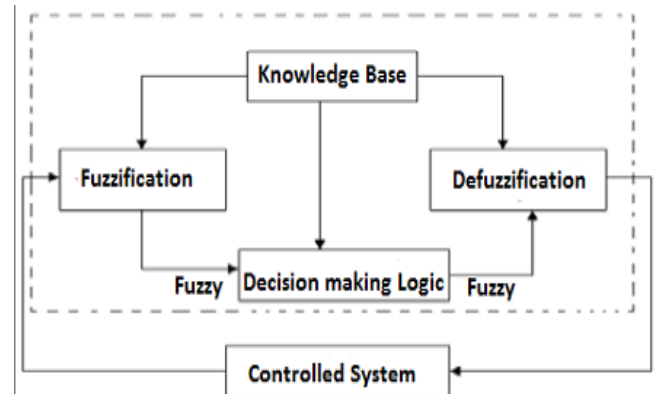

Fig.5. Basic structure of Fuzzy Logic controller.

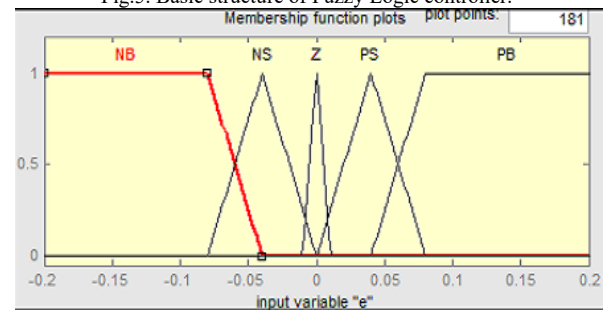

Fig.6. Error as input

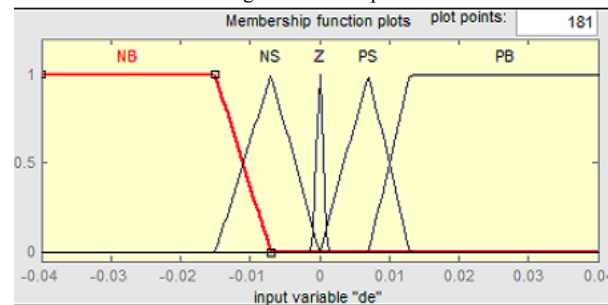

Fig.7. Change in Error as input

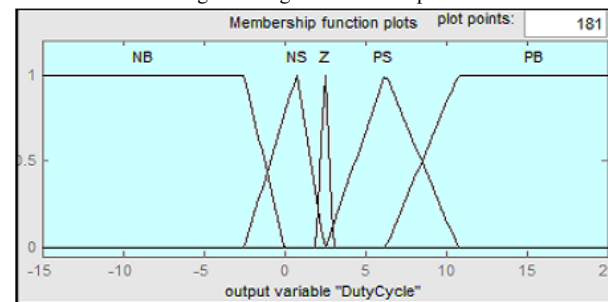

Fig.8. Output variables to defuzzification process

In this paper, an advanced control strategy, FLC is implemented along with UPQC for voltage correction through Series APF and for current regulation through Shunt APF. Error and Change in Error are the inputs and Duty cycle is the output to the Fuzzy Logic Controller as shown in Fig.6-Fig.8.



In the decision-making process, there is rule base that links between input (error signal) and output signal. Table 1 shows the rule base exercised in this proposed Fuzzy Logic Controller.

e	de	NB	NS	Z	PS	PB
NB		PB	PS	NS	NS	NB
NS		PS	PS	NS	PB	NB
Z		NB	NB	NS	PS	PB
PS		NS	NS	PB	NB	PS
PB		NS	NS	PB	PB	PB

TABLE.1. FUZZY RULE REPRESENTATION

### C. Hybrid Fuzzy-PID Controller

Although it is possible to design a fuzzy logic type of PID controller by a simple modification of the conventional ones, via inserting some meaningful fuzzy logic IF- THEN rules into the control system, these approaches in general complicate the overall design and do not come up with new fuzzy PID controllers that capture the essential characteristics and nature of the conventional PID controllers. Besides, they generally do not have analytic formulas to use for control specification and stability analysis. The fuzzy PD, PI, and PI+D controllers to be introduced below are natural extensions of their conventional versions, which preserve the linear structures of the PID controllers, with simple and conventional analytical formulas as the final results of the design. Thus, they can directly replace the conventional PID controllers in any operating control systems (plants, processes).

The main difference is that these fuzzy PID controllers are designed by employing fuzzy logic control principles and techniques, to obtain new controllers that possess analytical formulas very similar to the conventional digital PID controllers.

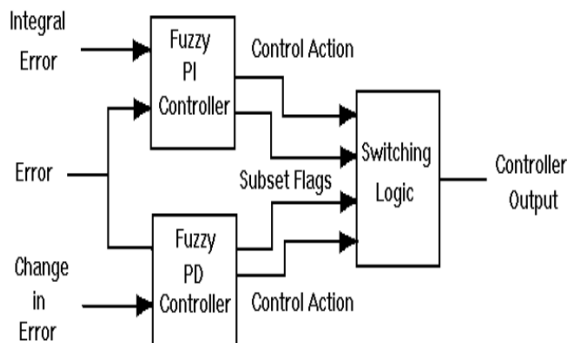

Figure.9. Hybrid Fuzzy PID Controller.

## VI. MATLAB/SIMULATION RESULTS

### Case 1: Uncompensated System

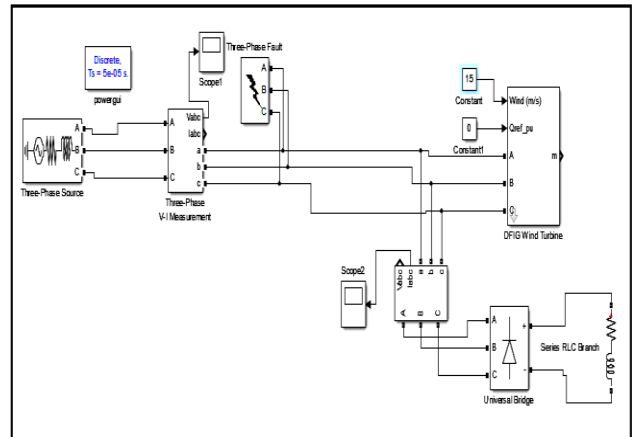

Fig.10. Matlab/Simulink circuit diagram for uncompensated system.

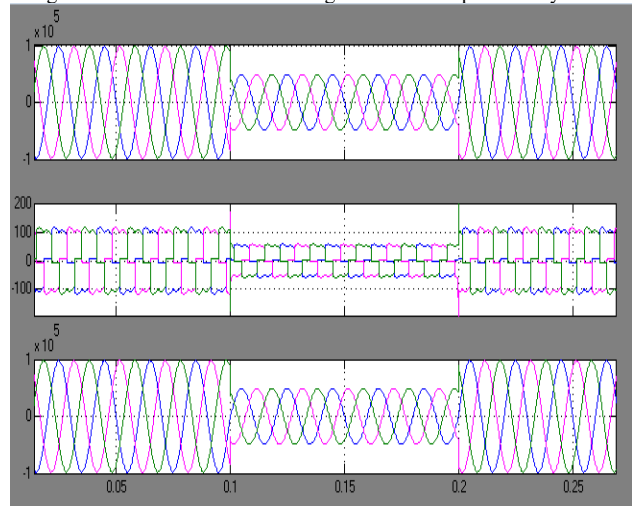

Fig.11. Supply voltage, Load current, load voltage for without UPQC on sag condition.

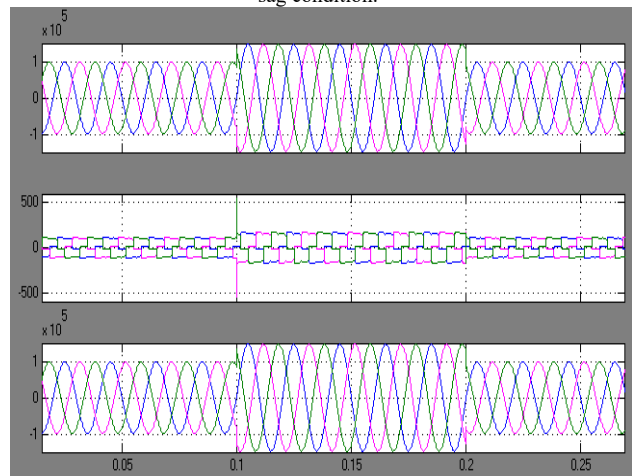

Fig.12. Supply voltage, Load current, load voltage for without UPQC on swell condition

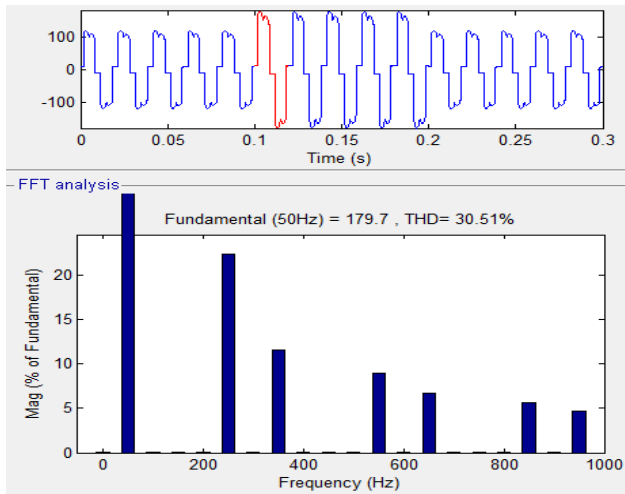

Fig13.Total harmonic distortion for uncompensated system, THD =30.51%

**Case-2: compensated System with PI controlled UPQC**

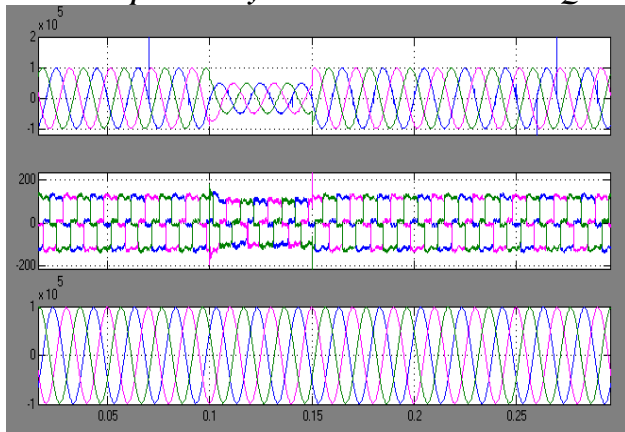

Fig.14. Supply voltage, Load current, load voltage for with UPQC on sag condition.

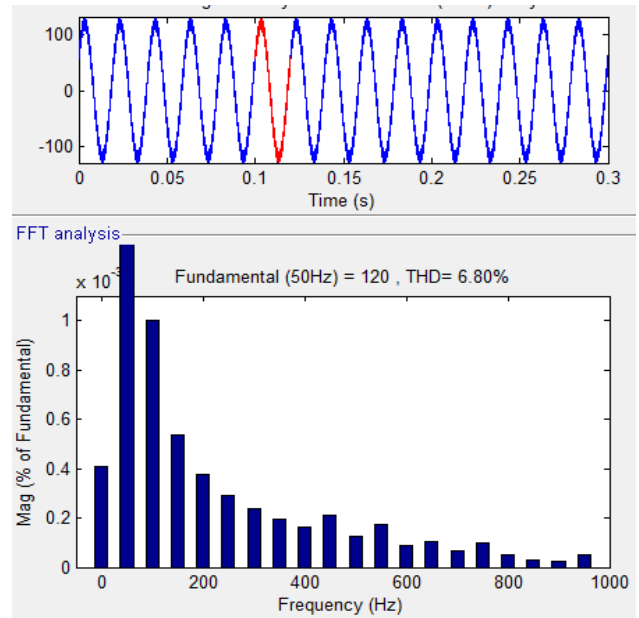

Fig.15.Total harmonic distortion for UPQC compensated system, Base THD =6.80%.

**Case-3: UPQC with Fuzzy Logic Controller**

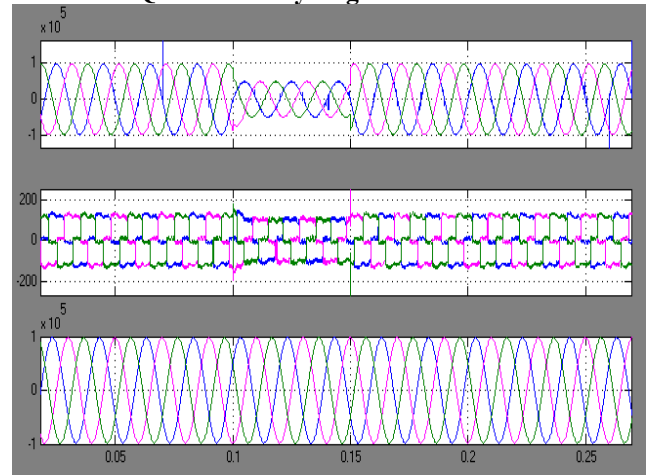
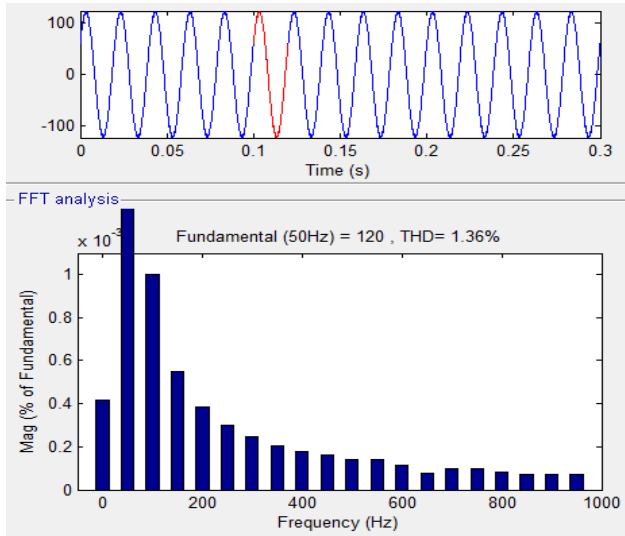

Fig.16. Supply voltage, Load current, load voltage for UPQC with fuzzy on sag condition.



**Case 4: UPQC with Hybrid Fuzzy Logic Controller**

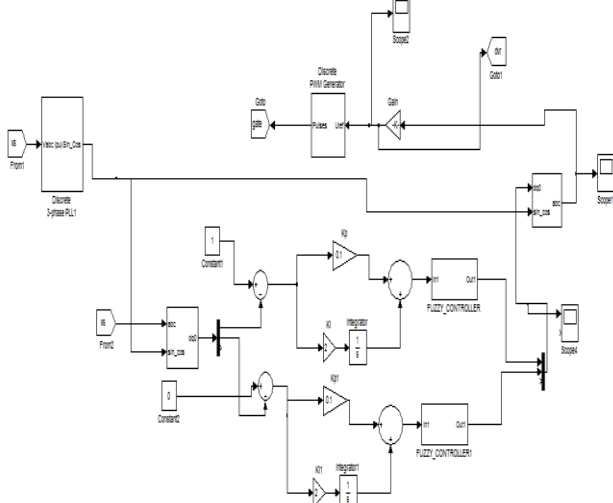

Fig.18.Hybrid Fuzzy logic control block diagram for UPQC system.

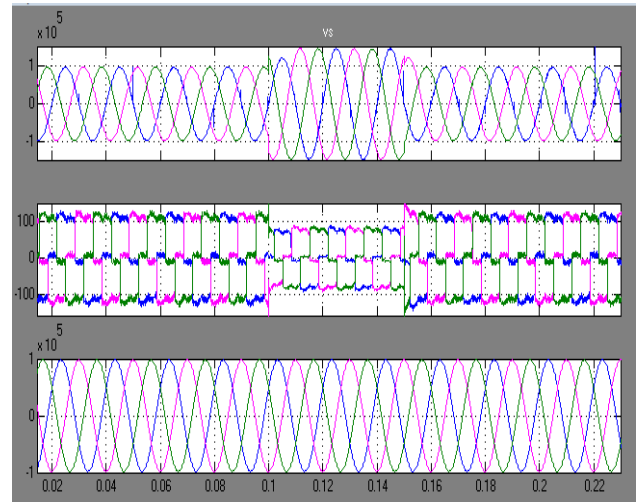

Fig.19.Supply voltage, Load current, load voltage for UPQC with Hybrid Fuzzy Logic Controller on Swell condition.

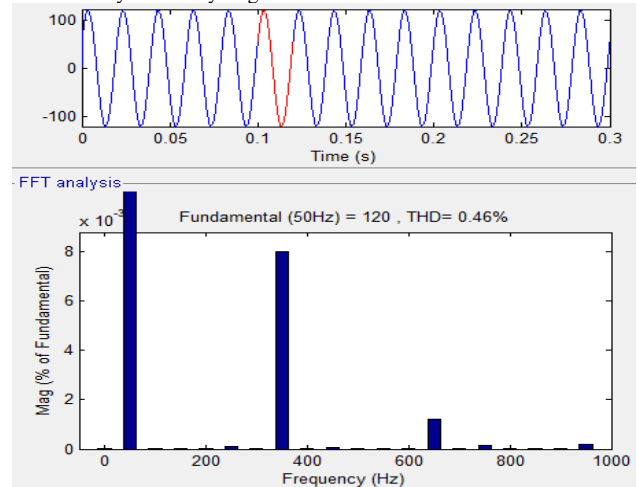

Fig.20.Total harmonic distortion for UPQC with fuzzy compensated system, THD=0.46%.

TABLE .PERFORMANCE COMPARISON

SYSTEM	LOAD CURRENT THD IN %
Uncompensated system	30.51
UPQC with PI Controller	6.80
UPQC with Fuzzy Logic Controller	1.36
UPQC with Hybrid Fuzzy Logic Controller	0.46

**VII.CONCLUSION**

In this proposed system we designed unified power quality conditioner with the control technique by PI and

Fuzzy controller. The PQ problems -voltage sag and current harmonics are simulated using MATLAB in a grid connected wind power system. The hybrid fuzzy controlled UPQC is implemented for PQ enhancement to diminish both voltage sag and current harmonics and the simulation results are also compared with conventional PI controller. From the simulation results, the PI controlled UPQC completely mitigates voltage sag but the load current harmonics obtained is not within the acceptable limits. The Fuzzy Logic Controlled UPQC completely mitigates voltage sag. For mitigation of voltage swell and to improve power quality Hybrid fuzzy logic controller is used.

### REFERENCES

- [1] Frede Blaabjerg and Ke Ma, "Future on Power Electronics for Wind Turbine Systems," IEEE Journal of Emerging and Selected Topics in Power Electronics, vol. 1, no. 3, pp. 139- 152, September 2013.
- [2] Zheng Wang, Bo Yuwen, Yongqiang Lang and Ming Cheng, "Improvement of Operating Performance for the Wind Farm With a Novel CSC-Type Wind Turbine-SMES Hybrid System," IEEE Transactions on Power Delivery, vol. 28, no. 2, pp. 693-703, April 2013.
- [3] M. Jahangir Hossain, Hemanshu R. Pota, Valeri A. Ugrinovskii and Rodrigo A. Ramos, "Simultaneous STATCOM and Pitch Angle Control for Improved LVRT Capability of Fixed-speed Wind Turbines," IEEE Transactions on Sustainable Energy, vol. 1, no.3, pp. 142-150, October 2011.
- [4] Christian Wessels, Nils Hoffmann, Marta Molinas, Friedrich Wilhelm Fuchs, "Statcom Control at Wind farms with Fixed Speed Induction Generators Under Asymmetrical Grid Faults," IEEE Transactions on Industrial Electronics, vol. 60, no. 7, pp. 2864-2873, July 2013.
- [5] Mahmoud M. Amin and Osama A. Mohammed, "Development of High-Performance Grid-Connected Wind Energy Conversion System for Optimum Utilization of Variable Speed Wind Turbines," IEEE Transactions on Sustainable Energy, vol. 2, no. 3, pp. 235-245, July 2011.
- [6] Yazhou Lei, Alan Mullane, Gordon Lightbody, and Robert Yacamini, "Modeling of the Wind Turbine With a Doubly Fed Induction Generator for Grid Integration Studies," IEEE Transactions on Energy Conversion, vol. 21, no.1, pp. 257-264, March 2006.
- [7] S. Khalid and Bharti Dwivedi, "Power Quality Issues, problems, Standards and their Effects in Industry with Corrective Means," International Journal of Advances in Engineering and Technology, vol. 1, no.2, pp. 1-11, May 2011.
- [8] P.Karuppanan and Kamala Kanta Mahapatra, "Active Harmonic Current Compensation To Enhance Power Quality," Electrical Power And Energy Systems, vol. 62, pp. 144-151, 2014.
- [9] M. Shiddiq Yunus, Mohammad A. S. Masoum, and A. AbuSiada, "Application of SMES to Enhance the Dynamic Performance of DFIG During Voltage Sag and Swell," IEEE Transactions on Applied Superconductivity, vol. 22, no, 4, August 2012
- [10] P. Karuppanan and Kamala Kanta Mahapatra, "PI and Fuzzy Logic Controllers for Shunt Active Power Filter," ISA Transactions, vol. 51, pp. 163-169, 2012.
- [11] Andres E. Leon, Marcelo F. Farias, Pedro E. Battaiotto, Jorge A. Solsona and Maria Inés Valla, "Control Strategy of a DVR to Improve Stability in Wind Farms Using Squirrel-Cage Induction Generators," IEEE Transactions on Power Systems, vol. 26, no. 3, pp. 1609-1617, August 2011.
- [12] Sharad W. Mohod and Mohan V. Aware, "A STATCOM Control Scheme for Grid Connected Wind Energy System for Power Quality Improvement," IEEE Systems Journal, vol. 4, no. 3, pp. 346-352, September 2010.