

---

# Experimental and Computational Analysis of Piston Coated With Aluminium Silicon Metal Matrix Composite Material

---

<sup>1</sup>Mr.Poralla Venkatakrishna, <sup>2</sup>Mr.Dumpa Sureshreddy, <sup>3</sup>Mr. Prashanth.A

<sup>1</sup> Pg. Scholar, Dept of MECH, Mallareddy Engineering College, main campus, maisammaguda, Hyderabad, Telangana, INDIA

<sup>2</sup> Assistant Professor, Dept of MECH, Mallareddy Engineering College, main campus, maisammaguda, Hyderabad Telangana, INDIA

<sup>3</sup> Assistant Professor, Dept of MECH, Mallareddy Engineering College, main campus, maisammaguda, Hyderabad Telangana, INDIA

Email: [venkatakrishna1516@gmail.com](mailto:venkatakrishna1516@gmail.com), Email: [dumpasureshreddy@gmail.com](mailto:dumpasureshreddy@gmail.com), Email id: [adunuri327@gmail.com](mailto:adunuri327@gmail.com)

## Abstract

*A piston is a component of mutual engines, mutual pumps, gas compressors and gas cylinders, amongst alternative similar mechanisms. it's the shifting factor that's contained by employing a cylinder and is formed fuel-tight by approach of piston jewelry Piston that transfer the combustible gases strength to the rod. to boost the potency of the engine there's a wish to possess a glance at concerning the piston. Pistons that square measure normally created up with alloy steels that show the grate resistant con to structural masses. among the mission we have a tendency to style a piston by the utilization of CatiaV5 layout computer code and that we did the structural load analysis by approach of constructing use of diverse substances in conjunction with composites on piston in Ansys worktable computer code. And achieved the chemical and mechanical looking for to ascertain the high-quality and performance of piston, and compare the outcomes of simulation analysis and looking for outcomes to make sure style is secure.*

**Key phrases:** piston, catia, ansys, ALUMINIUM SILICON metallic MATRIX

## Introduction

We for all intents and purposes bring our consuming Engines with no thought don't we tend to? Whatever we do is acquire our vehicles, jump in and drive around. There is, be that as it may, a past filled with improvement to get a handle on concerning. The minimized, all around Toned, intense and amazingly calm motor that has all the earmarks of being murmur underneath your vehicle's hood basically wasn't the manageable brute it gives off an impression of being at present. it had been uproarious, it acclimated thunder and it acclimated be somewhat huge. Truth be told, one in all the appallingly first motors that had been shaped wasn't even simply like the motor we as a whole know in this way well of nowadays. a {inside an interior an enclosed} ignition motor is illustrated as partner motor amid which the vitality of the fuel is released inside the motor and utilized straightforwardly for mechanical work, as antagonistic partner outer burning motor amid which a different combustor is utilized to consume the fuel. the internal ignition motor was shaped and created inside the late 1800s. it's bigly affected society, and is considered one in all the chief critical creations of the most recent century. the inward ignition motor has been the motivation for the effective advancement of the numerous modern advances.

A cylinder might be a component of proportional motors,

Responding pumps, gas compressors and gas barrels, among various comparative systems. it's the moving component that is contained by a chamber and is framed water/air proof by cylinder rings. In relate motor, its motivation is to exchange compel from expanding gas inside the chamber to the pole by means of an interfacing pole or potentially pole. In a pump, the perform is switched and drive is exchanged from the pole to the cylinder for the point of pressure or launching the liquid inside the barrel. In a few motors, the cylinder conjointly goes about as a valve by covering and revealing ports inside the barrel divider.

Vehicle parts region unit in decent request presently because of intensified utilization of autos. The intensified request is because of enhanced execution and lessened cost of those parts. R&D and testing engineers should create pivotal parts in most brief achievable time to lessen dispatch time for spic and span stock. This requires comprehension of late innovations and quick retention inside the advancement of late stock .A cylinder might be a moving component that is contained by a chamber and is framed hermetically sealed by cylinder rings. In relate motor its motivation is to exchange from expanding gas inside the barrel to the wrench shaft by means of interfacing bar as well as bar. As a significant half in relate motor cylinder bears the cyclic power per unit region and latency powers at work and this working condition could cause the exhaustion mischief of the cylinder. The examinations show that most noteworthy anxiety appears on the higher complete of the cylinder and stress fixation is one in all the chiefly explanation behind weariness disappointment

### **Forces**

The significant powers following abreast of the cylinders are as per the following:

Latency drive caused by the high repeat of responding movement of cylinder

Grating between the barrel dividers and also the cylinder rings

Powers owing to extension of gasses Powers acting owing to the pressure of gasses Contact at gudgeon stick gap.

### **Objective:**

Outlining the cylinder for a hundred and fifty cc gasoline motor taking connection to the present cylinder. Configuration is changed to incite higher outcomes Making of 3D display in Solid works so by abuse Ansys work seat for examination Lattice of 3D demonstrate in ansys steel module

Material entirely unexpected general and composite materials ar chose for the examination and study. Concoction Testing are done on metallic component synthetic component network material.

Mechanical hurtful testing can performed to learn the texture quality of the texture to make certain it deals with given weight stack.

### **Materials:**

A seal material is fulfilled the anxiety set by the running conditions. also, the texture should be safe against hurt even in crisis conditions. physical property and consumption protection of the ring material is required. The ring covering, if connected, needs to function admirably close by each the ring and in this manner the liner materials, yet like the lubricator.

by and large favored materials territory unit

- cast press
- aluminum amalgams
- grey fashioned iron
- chromium coatings for rings

Thin, exhausting coatings made by PVD or CVD exemplify covering syntheses like metal compound (TiN), Cr compound (CrN); however coatings of this kind zone unit directly utilized totally for small arrangement generation for rivalry motors and picked creation motors (Federal Mogul, 1998, Broszeit et al., 1999). Multilayer TiTiN coatings are by experimentation kept onto vigorous cylinder rings, and in this manner the covering is asserted to be extra wear safe than a Cr plated or phosphated surface, quite once the measure of layers is high (Zhuo et al., 2000).

### Introduction to composites:

Composite materials have been broadly used to enhance the execution of different sorts of structures. Contrasted with ordinary materials, the fundamental points of interest of composites are their better firmness than mass proportion and additionally high quality to weight proportion. In view of these favorable circumstances, composites have been progressively joined in basic segments in different modern fields.

### Basic Concepts of Composite Materials

Composite materials are basically cross breed materials framed of various materials with a particular finish goal to use their individual auxiliary focal points in an exceedingly solitary basic material. The constituents are joined at a naturally visible level and aren't solvent in one another. The secret is the perceptible examination

of a cloth whereby the elements are often recognized by the vacant eye. various materials are often consolidated on a small scale, as an example, in alloying of metals, but the next material is, for each single handy reason, noticeably consistent, i.e. the elements cannot be recognized by the vacant eye and essentially acts along.

### Theoretical Analysis:

By polishing off Associate in Nursing analysis and experiments on the piston , and counting on the principle of cooling piston with oil so as to allow the piston to hold additional thermal masses while not having additional damages with increasing the engine speed rate . And there square measure 2 varieties of pistons in keeping with the cooling case , the primary sort is that the piston with the cooling gallery within which the cooling oil is passed , and also the second sort is that the solid piston wherever the cooling is proscribed to the below crown surface solely.

It has been developed a program for analysis internal-combustion engine piston .This program depends on the Finite parts methodology within the procedure of study.

### HeatTransfer Coefficients Calculations:

The heat transfer from the combustion gases is assumed to be just like the turbulent heat transfer of gases in a verycylinder as follows:

The heat transfer from the combustion gases is assumed to be similar to the turbulent heat transfer of gases in a cylinder as follows:

$$Nu = C Re^m Pr^n$$

Maximum Thickness of Barrel (t<sub>3</sub>)

$$t_3 = 0.03 * (D + b + 4.5 \text{mm})$$

Where, b = Stress calculation

Stress on Piston Crown

$$b = t_1 + 0.4$$

Stress calculation

Stress on Piston Crown

$$6b = \frac{3pD^2}{16tH^2}$$

Thermal Stress

$\Delta t = E \cdot \text{constant of thermal Expansion} \cdot \text{Temp. Difference}$ .

### Literature survey

Aluminum alloys are ready to cast by all common casting techniques (Budinski 2001).

- In order to improve the wear performance, a metal based insert is reinforced with the base alloy. Cast iron and steel inserts normally reinforced with the light weight alloy during the casting process. To achieve the bonding between aluminum and cast iron, special patented processes are used. The presence of dirt and oxide induces trouble to the bonding between insert and alloy. The component was coated with a tin layer by dipping or electro plating and subsequent heat treatments were carried out before casting (Cole and Andrew T 1991).
- Gravity die casting and the pressure casting methods are used for the Al-Fin process. A special casting technique derived from the so called Al-Fin process is used in the manufacture of piston by gravity die casting and squeeze casting method. Al-Fin process is also known as Al-Fer process which is achieved by diffusion bond between the insert and aluminum alloy.
- Zone Ching Lin and Din yanchen (1995) studied on Cubic Boron Nitride (CBN) a sintered product, which can be used as a cutting tool material for hard turning and for higher productivity.

### Introduction to CATIA

CATIA (computer helped three-dimensional intelligent application) is a multi-stage CAD/CAM/CAE business programming suite created by the French organization DASSAULT SYSTEMS. Written in the C++ programming dialect, CATIA is the foundation of the Dassault frameworks item lifecycle administration programming suite.

CATIA is mechanical plan programming. It is an element based-parametric strong displaying configuration instrument that exploits the simple to-learn Windows graphical UI. You can make completely cooperative 3-D strong models with or without limitations while using programmed or client characterized relations to catch plan expectation.

### Modeling of Piston

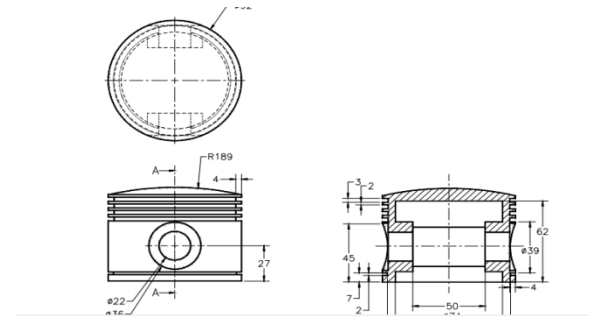

Dimensions for piston

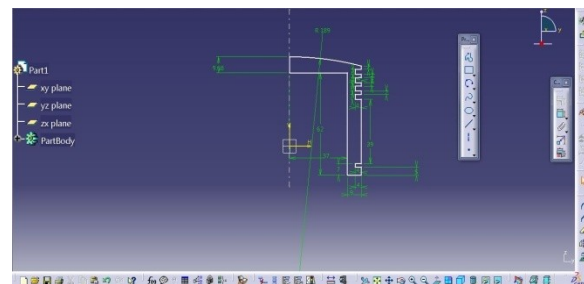

Draw sketch as follows

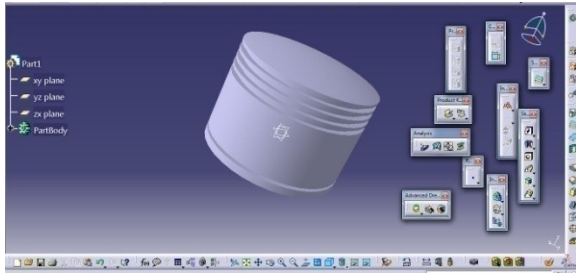

Now go to features and select revolve option

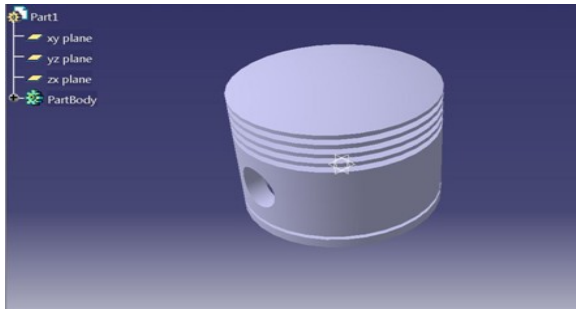

Piston 3d model

## Concepts of Analysis

### Meshing:

The product utilizes the Finite component technique (FEM). FEM may be a numerical technique for work building plans. FEM is acknowledged because the customary examination technique thanks to its all comprehensive statement and reasonableness for computer execution. FEM isolates the model into various very little bits of basic shapes known as parts adequately displacement an unplanned issue by various basic problems that ought to be settled all the whereas.



CAD model of a part

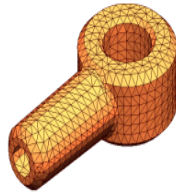

Model subdivided into small pieces (elements)















### Finite Element Analysis

Limited segment Analysis (FEA) could be a PC based numerical strategy for calculative the quality and

conduct of designing structures. It will be acclimated ascertain diversion, stretch, vibration, clasp conduct and heaps of option wonders. It can likewise be acclimated break down nearly nothing or largescale avoidance underneath stacking or connected relocation. It utilizes a numerical system known as the limited segment strategy (FEM).

ANSYS 14.5 conveys creative, sensational recreation innovation propels in each real Physics teach, alongside upgrades in registering velocity and improvements to empowering advances, for example, geometry taking care of, lattice and post-preparing. These headways alone speak to a noteworthy advance ahead on the way ahead in Simulation Driven Product Development. Be that as it may, ANSYS has come to much further by conveying this innovation in an inventive reenactment structure, ANSYS Workbench14.5The ANSYS Workbench condition is the paste that ties the recreation procedure; this has not changed with version.14.5 In the first ANSYS Workbench, the client communicated with the examination in general utilizing The stage's venture page: propelling the different applications

The software offers the following types of studies:

Study type	Study icon		
Static		Modal Time History	
Frequency		Harmonic	
Buckling		Random Vibration	
Thermal		Response Spectrum	
Design Study		Drop Test	
Nonlinear Static		Fatigue	
Nonlinear Dynamic		Pressure Vessel Design	

### Material Properties



Material	Density Kg/m <sup>3</sup>	Young's modulus (Mpa)	Poisson's ratio	Bulk modulus (Mpa)	Shear modulus (Mpa)
magnesium alloy	1800	45000	0.35	50000	16667
silicon carbide	3210	4.4e+005	0.21	2.5287e+005	1.8182e+005
42crmo4	7830	2.1e+005	0.30	1.75e+005	80769
al 6061b4c	2680	1.97e+005	0.32	1.8241 e+005	74621
Aluminum metal matrix	2700	78000	0.32	72222	29545

### Analysis on Piston

### Mesh

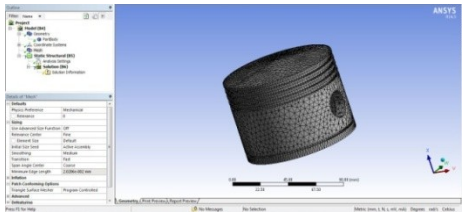

### Load condition

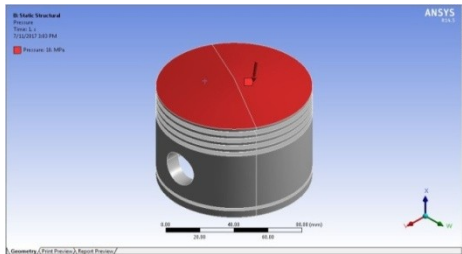

### Magnesium alloy

#### Stress

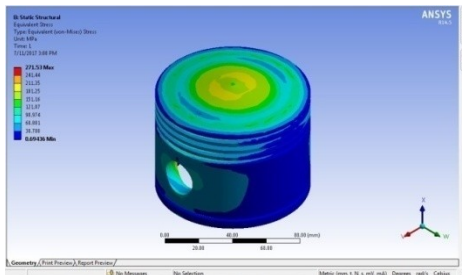

#### Deformation

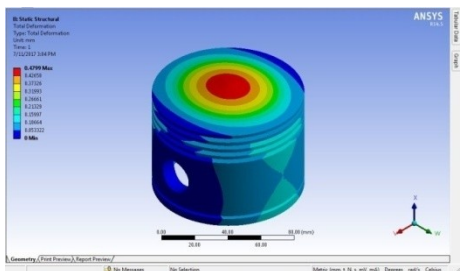

### Strain

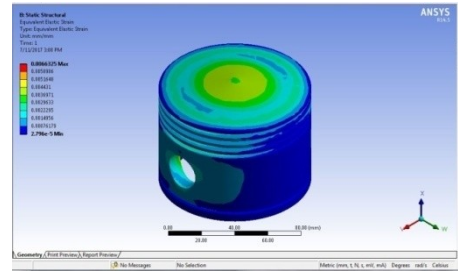

### Silicon carbide

#### Stress

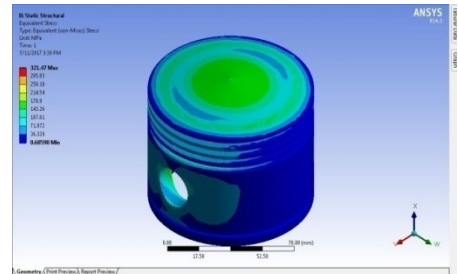

#### Deformation

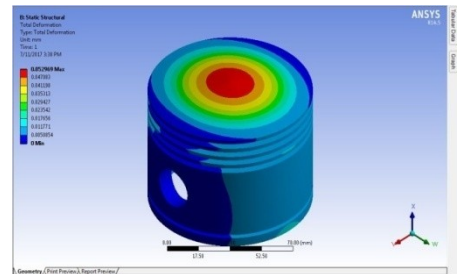

### Strain

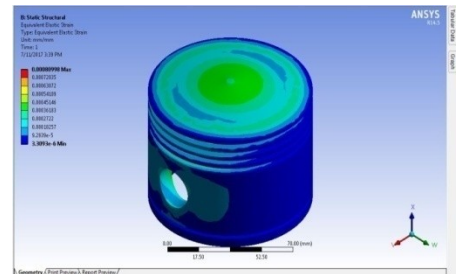

### 42crmo4

#### Stress

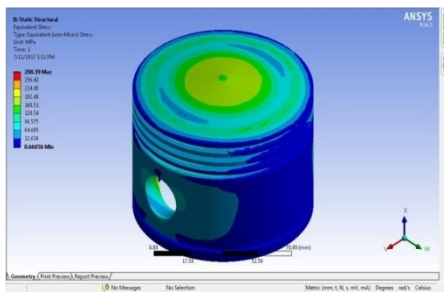

Deformation

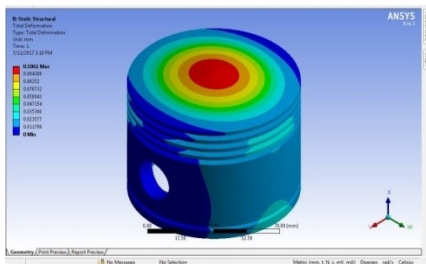

Strain

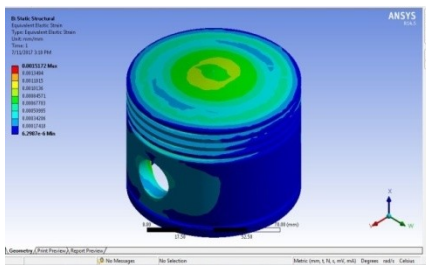

Al 6061+b4c

Stress

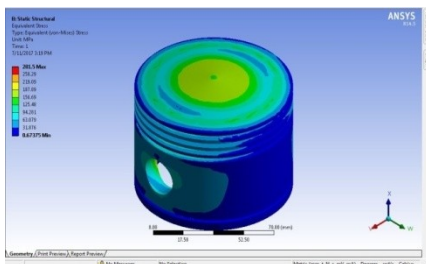

Deformation

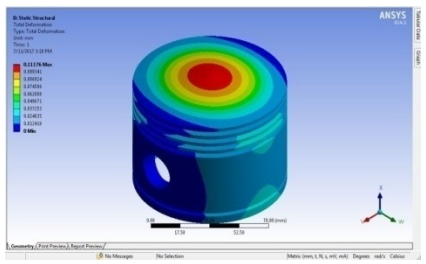

Strain

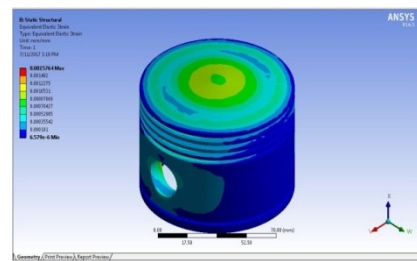

Aluminum metal matrix

Stress

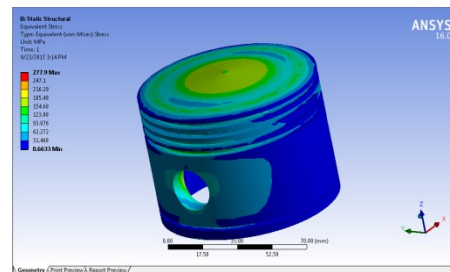

Deformation

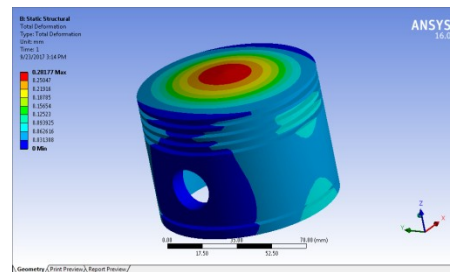

Strain

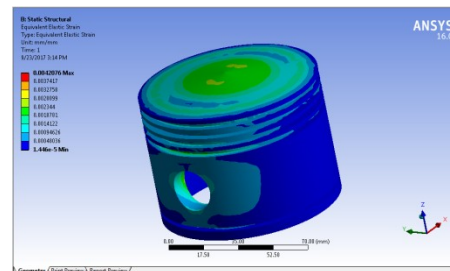

Analysis result table

Maximum values after analysis are noted in table.

Material	Maximum stress (Mpa)	Total deformation (mm)	Maximum strain
magnesium alloy	271.53	0.4799	0.0066325
silicon carbide	321.47	0.052969	0.00080998
42CrMo4	288.39	0.1061	0.0015172
Al 6061+B4C	281.5	0.11176	0.0015764
Aluminum metal matrix	277.90	0.28177	0.0042076

## Conclusion

- Testing, Modeling and investigation of cylinder is finished.

- Brief learn about cylinders, outlines, applications, and diverse composite materials is done in this venture.

- On a similar measurement of existing cylinder physical model, one CAD demonstrate is produced in CATIA V5 programming.

- Modeling of cylinder is done in CATIA V5 outline programming by utilizing different orders and instruments.

- The CATIA document is changed over into IGS record and imported to ansys workbench programming for investigation.

- First Static basic investigation is done on cylinder at 10mpa weight stack conditions, on same material properties of aluminum silicon metal framework.

- First Static basic examination is completed on cylinder at 10MPa weight with five unique materials, for example, magnesium combination, silicon carbide, 42CrMo4 (exceptional steel composite), Aluminum compound (6061) +5% Boron carbide (B4C) and aluminum metal network in ansys workbench

- Maximum stretch, disfigurement, most extreme strain and greatest shear push are noted and arranged.

## Chemical testing results

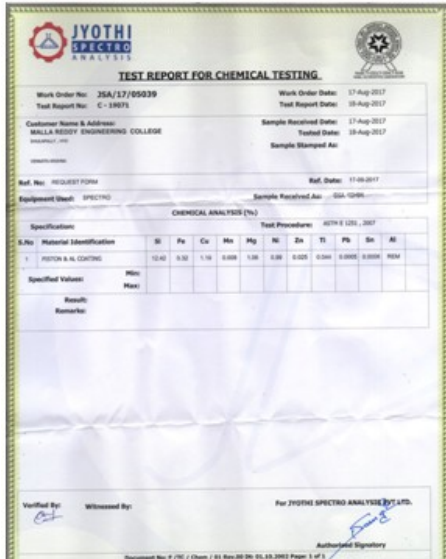

## Mechanical testing results

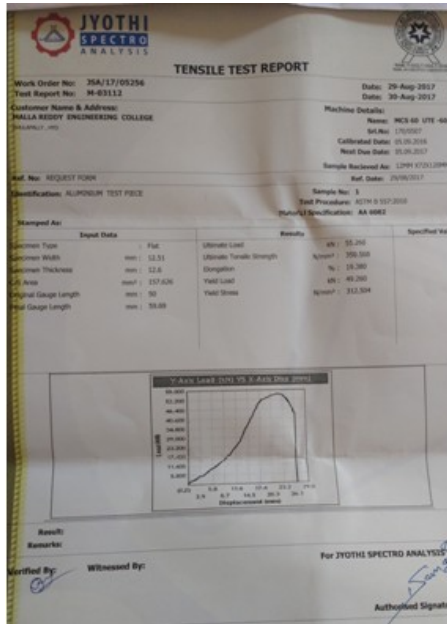



- Magnesium compound and aluminum metal lattice having the almost same minimum anxiety esteem however aluminum metal grid indicates less twisting contrast with magnesium composite.
- Piston made up of aluminum silicon metal framework is chosen for testing and examination reason.
- Chemical testing is performed on aluminum silicon framework composite material to ensure quality and amount of amalgam material I: e rate is concurring required detail.
- Mechanical testing (damaging) is performed by all inclusive mechanical testing machine, to discover its yield quality and other mechanical properties.
- On the working burden condition for cylinder i.e 10 mpa , after examination on ansys workbench programming we get the greatest anxiety esteem is 277.90 mpa.
- After ruinous mechanical testing of same material estimation of max yield push is 312.504.
- As the CAD configuration model of material aluminum silicon metal framework works under 277.90 MPa which is not as much as yield push estimation of material, consequently we can reason that outline is protected.

## References

- [1] R. Ravi Raja Malarvannan and P. Vignesh "Trial Investigation and Analysis of Piston by utilizing Composite Materials" Vol 04, Article-K100; November 2013.
- [2] Mr. Rahul DevGuptha, Dr. Vivek Jain and Er.KrishanKanth Sharma "Trial Investigation and Analysis of wear parameters on Al/Sic/Gr Metal Matrix Hybrid composite by Taguchi Method" Volume 13 Issue 9 Version 1.0 Year 2013.
- [3] PrakashGadade and Arun L.R "Characterisation of aluminum-FlyashAlumina composite for cylinder examination by cae devices" Vol.2, Issue 12, December 2013.
- [4] Ashwani Kumar, Shaik Imran Behmad, Pravin P Patil "Thermo-Mechanical and Vibration Analysis of the I.C. Motor Piston made of SiC strengthened ZrB2 composite utilizing Finite Element Method(ANSYS)" 2014.
- [5] Er. RachitMarwaha, Mr. Rahul Dev Gupta, Er. Krishan Kant Sharma "Assurance and Experimental Investigation Of Weight Loss On Al/Sic/Gr - Metal Matrix Hybrid Composite By Taguchi Method" Volume 2, Issue 11, November 2013.
- [6] Etsion, I.: An Optimum Step Design for Centering of Pistons. J. Liquids Eng., Trans. ASME, ser. I, vol. 97, no. 4, Dec. 1975. pp. 621-624.
- [7] A. Dolata-Grosz, M. Dyzia, J. Śleziona, J. Wieczorek "Composites Applied For Pistons," Volume 7 Issue 1/2007 37-40.
- [8] S.M. Sapuan, M.S..D. Jacob, F. Mustapha and N. Ismail , "A model knowledgebased framework for material determination of earthenware network composites of car motor segments" Vol 23, 2002 page 701-708.
- [9] J. I. Tune and K. S. Han, "Mechanical Properties and Solid Lubricant Wear Behavior of Al/Al<sub>2</sub>O<sub>3</sub>/C Hybrid Metal Matrix Composites Fabricated by Squeeze Casting Method" Journal of Composite Materials (1997) 31: 316.

[10] Mahanthesh G1, Umashankar 2 "Planning and Property Evaluation Of Aluminum Alloy (6061) Reinforcedwith Bottom Ash Particulate Composite (Albap Composite)" Volume 01, Issue 04.

[11] Mechanical properties of composite materials by Frank.W.Zok and Carlos G.Levi

[12].Abbott, G.L., Jenkins, R.J. also, Parker, W.J. "Streak strategy for deciding Thermal Diffusivity, Heat Capacity and Thermal Conductivity," Journal of Applied Physics, Vol. 31, Issue 9.

[13].AchuthaKini, Gowri Shankar, M.C., Jayashree, P.K., RavirajShetty and Sharma, S.S. [2013] "Survey onEffect of Silicon Carbide on Stir Cast Aluminum Metal Matrix Composites," International Journal of CurrentEngineering and Technology, ISSN: 2277-4106, Vol. 3, Number.

[14].Anil Kumar, H.C., Hebbar, H.S. also, Ravishankar, K.S. [2011] "Mechanical Properties of Fly Ash Reinforced Aluminum Matrix Alloy," International Journal of Mechanical and Materials Engineering, Vol. 6, 41-45.

[15].Antony raj Arockiaswamy, German, R.M., Wang, Suri and Park [2013] "DSC examination of Al 6061 aluminum amalgam powder by fast hardening," Journal of Thermal Analysis and Calorimetry, 361-366.

[16].AshishSrivastava, PrayagGarg, Avdhesh Kumar, Yamini Krishna and Kanu Kumar Varshney [2014] "A Review on Fabrication and Characterization of Hybrid Metal Matrix Composites," International Journal ofAdvanceResearch and Innovation, ISSN: 2347-3258, Vol. 1, 242-246.

#### **AUTHORS:**

**Mr.PORALLA VENKATAKRISHNA**



Pg. Scholar, Dept of MECH, Mallareddy Engineering College, main campus, maisammaguda, Hyderabad, Telangana, INDIA

Email:venkatakrishna1516@gmail.com

Phone No: 9491037839

#### **Mr.DUMPA SURESH REDDY**



Assistant Professor, Dept of MECH, Mallareddy Engineering College, main campus, maisammaguda, Hyderabad Telangana, INDIA

Email:dumpasureshreddy@gmail.com

Phone No: 9642220220

#### **Mr.PRASHANTH.A**



Assistant Professor, Dept of MECH, Mallareddy Engineering College, main campus, maisammaguda, Hyderabad Telangana, INDIA

Email:adunuri327@gmail.com

Phone No: 8790833371