Street light control based on solar and health monitoring of vehicle Employing GSM, GPS and RFID

B. Laxman

Assistant Professor, Department of ECE
Chaitanya Institute of Technology and Science, Warangal, Telangana.

Abstract: *Now a day's lots of accidents happens on highway due to increase in traffic and also due to rash driving of the driver. And in many situations the family members or the ambulance and police authority is not informed in time. This result in delaying help reached to the person suffered due to accident. Street lights are the consumer of energy in the cities, consuming up to fifty percent of the city's energy. In order to reduce energy consumption, an intelligent street light system based on LED lamps and wireless communication technologies can be designed. It can also help in monitoring of street light system and fault detection. If fault occurs then the GSM sends the message to control unit. In the present scenario traffic violations are increasing rapidly. It gives rise to major problems which are beyond human control directly and therefore there is a need for automation. An RFID reader present in the vehicle senses the directions on the tag as a reference input. Here, the passive RFID tag is used in the signboard which is having a battery supplied from the solar panel.*

The concept of a traffic sign recognition based on RFID. Two computer programs are developed. First allows the RFID tags, the second one reads the signs and displays them on the screen in such way that the driver had knowledge of the most important traffic signs, under which she or he is. As well as it sends the voice message to the driver through voice module APR9600. As well as we can monitor the vehicles health by using different sensors. i.e, smoke sensor, temperature sensor and alcohol sensor. By using the GSM module we can alert the owner through message. If the driver is in drunken state then alcohol sensor reaches the cutoff point it gives the data to the microcontroller then it sends the message to alert the owner by using GSM module and GPS to identify the location if accident occurs, as smoke sensor it gives the data to the microcontroller when the vehicle needs service, temperature sensor will activates when the vehicle engine is in over heat.

1.INTRODUCTION

This project is used to detect a vehicle movement on road to switch ON the street lights that are ahead of the vehicle and to switch OFF the glowing lights when vehicle passes away from the lights. This will help to save electrical energy. The power supply consists of step down transformer 230/12V , which step downs the voltage to 12V AC .This is converted to DC using a bridge rectifier.In present days many accidents are occurring especially on highways and we do not have proper prior information indicators about road status or petrol bunks. This can be done easily with the help of RFID technology using embedded system. Speed breakers, crossroads, reverse bends, blind turns, one-ways, steep ascents, work-in-progress, railway lines and silent zones are some of the vast multitude of road oddities one may come across on the average drive. Sometimes these oddities are accompanied by road-signs.

RFID tags are categorized as either active or passive. Active RFID tags are powered by an internal battery and are typically read/write, i.e., tag data can be rewritten and/or modified. An active tag's memory size varies according to application requirements; some systems operate with up to 1MB of memory. Passive RFID tags operate without a separate external power source

and obtain operating power generated from the reader.In this system each vehicle is equipped with one micro controller, RFID reader ,voice playback module and RFID tags beside road to indicate different sings like speed breakers, speed limit, road turns etc.All road-related cautions and mandates will be provided to the driver in the vehicle itself, and dependency on road signs will be reduced drastically.

This also offers monitor the vehicles health by using different sensors.. By using the GSM module we can alert the owner through message. If the driver is in drunken state then alcohol sensor reaches the cutoff point it gives the data to the microcontroller then it sends the message to alert the owner by using GSM moduleand GPS to identify the location if accident occurs, as smoke sensor it gives the data to the microcontroller when the vehicle needs service, temperature sensor will activates when the vehicle engine is in over heat.

1.2 EXISTING METHOD:

Now a days, there are a number of techniques which are purposefully used and are being build upfor street light monitoring.Solar and Global System for Mobile Communication (GSM) arethe latest trends and are one of the best combination to be used in the project. Hence,a combination of both of thesetechnologies is used

in the project, To give a brief description of the project ,The existing system is used to save the electrical energy by monitoring the traffic of the vehicle as well as the intensity of the day light. And also sends the message to the control room if any light failures,In this case there will be no vehicle condition monitoring, and also there is no sign boards. **1.3 PROPOSED METHOD:**

In the present scenario traffic violations are increasing rapidly. It gives rise to major problems which are beyond human control directly and therefore there is a need for automation. An RFID reader present in the vehicle senses the directions on the tag as a reference input. Here, the passive RFID tag is used in the signboard which is having a battery supplied from the solar panel.

The concept of a traffic sign recognition based on RFID. Two computer programs are developed. First allows the RFID tags, the second one reads the signs and displays them on the screen in such way that the driver had knowledge of the most important traffic signs, under which she or he is. As well as it sends the voice message to the driver through voice module APR9600. As well as we can monitor the vehicles health by using different sensors. i.e, smoke sensor, temperature sensor and alcohol sensor. By using the GSM module we can alert

the owner through message. If the driver is in drunken state then alcohol sensor reaches the cutoff point it gives the data to the microcontroller then it sends the message to alert the owner by using GSM module and GPS to identify the location if accident occurs, as smoke sensor it gives the data to the microcontroller when the vehicle needs service, temperature sensor will activates when the vehicle engine is in over heat.

2. LITERATURE SURVEY

It is very common these days to see solar panels based street lights. People became aware about the importance of moving from conventional resources based energy production to renewable energy based power production. We all know that fuel resources are going to fed us for only 50-60 years now. It is sure that we can't leave in a society without power. So we need to maximize the usage of renewable energy so that we can preserve conventional resources. Radio Frequency Identification (RFID) is an upcoming technology which has recently attracted the interest of the research community because of the extraordinary benefits it offers over their existing identification and data capturing technologies. This chapter is formatted to review the existing RFID literature and explore the issues in the present RFID system

since the technology is still in its acceptance phase.

Since the growth of RFID technology from 1900's, apart from its stated positive aspects, the technology also bears some concerns or issues. The intended purpose of this chapter is to examine the literature related to Radio Frequency Identification further extended academic research, and providing an insight into some of the outstanding and crucial issues hindering the growth of the RFID technology. There is a strong need to address these issues in order to provide a greater visibility and an increased product velocity of the RFID technology.

Radio Frequency Identification is a growing technology that has been around since early 1900's and was used in World War II. The pace of developments in RFID is as well apparent in the 21st century where even the modest of item like cloth bearing a small sticky patch of RFID and human implantation of RFID tag and that too of rice sized grain is the reality of the day.

2.1 SarathPatil G.S, RudreshS.M, Kallendrachari .K, Kiran Kumar.M: Automatic Street Light Control Using Sensors And Solar Panel: Solar street lights are becoming more common these days. But the limitation of this ordinary street light systems is

that it lacks intelligent performance. It is essential to automate the system so that we can conserve energy as well as maximize the efficiency of the system. This method suggested to maximize the efficiency of street light and to conserve the energy usage LED light sensor. Here automation is done by LDR sensor. Intensity of led street light can be controlled by IR sensor.

2.2 P.Eswaramoorthy, M. Arunkumar: Intelligent vehicle control based on identification of road signs by solar powered RFID : This deals with automatic speed limit on roads by using solar powered RFID technology to control on automobile. Due to traffic violations it gives rise to major problems which are beyond human directly and therefore there is a need for automation. An RFID reader present in the vehicle senses the vehicle speed limit on the tag as a reference speed input. The RFID tag is used in the signboard which is having a battery supplied from the solar panel. This reference speed is given to the control unit. Meanwhile the speed sensor present in the automobiles. We here suggest two braking systems in this paper. It's having an advantage of not supplying the power to rural area signboards.

2.3 SakshiAnand, Dr. Neelu Jain: Intelligent Street Light System Using RF

Transmission: An intelligent streetlight system based on LED lamps and wireless communication technologies can be designed. It can detect daylight and vary the intensity of the LED based street lamps as per the traffic flow. It can also help in monitoring of streetlight system and fault detection through RF wireless technology. The system is versatile, and extended as per our needs.

3. BLOCK DIAGRAM

3.1 INTRODUCTION

The information about the project block diagram, its description and working is shown in this chapter. It provides the list of hardware which requires for the project. Based on this we need to select the hardware components with proper characteristics. Here, the major issue is depending upon the result the components should be selected and are assembled in an appropriate manner. The circuit description is stated below.

3.2 BLOCK DIAGRAM DESCRIPTION

SOLAR PANEL:

Solar modules use light energy (photons) from the sun to generate electricity through the photovoltaic effect. The majority of modules use wafer-based crystalline silicon cells or thin-film cells based on cadmium telluride or silicon.

BATTERY:

A battery is an electrochemical cell (or enclosed and protected material) that can be charged electrically to provide a static potential for power or released electrical charge when needed.

POWER SUPPLY:

Plays a crucial role in every project. It is responsible for the conversion of 148 available power of one set of characteristics to meet specified requirements. Also it stabilizes the power.

LPC2148:

Microcontrollers are based on a 32/16 bit ARM&TDMI-S CPU with real-time emulation and embedded trace support, that combines the micro controller with embedded high speed flash memory.

GSM:

Global system for Mobile communication is a globally accepted standard for digital cellular communication.

SENSORS:

Sensors are used to measure variable changes taking place in surroundings or any obstacles.

GPS:

Global Positioning System is used to locate the position of location.

MAX232:

Operates at a broader voltage range from 3 to 5.5v.

RFID READER:

Typically contains a module (transmitter and receiver), a control unit and a coupling element. (antenna).

LCD:

Liquid Crystal Display used for display process.

RFID CARDS: Transponder, considered as a next generation barcode, is a miniscule microchip that is attached to an antenna.

ARM: By combining a high-performance ARM7-based microcontroller with a flexible LCD driver, this multi-chip module makes it easy to integrate advanced technology into everyday applications

VOICE RECORDER: The APR9600 device offers true single-chip voice recording ,non-volatile storage, and playback capability for 40 to 60 seconds. The device supports both random and sequential access of multiple messages.

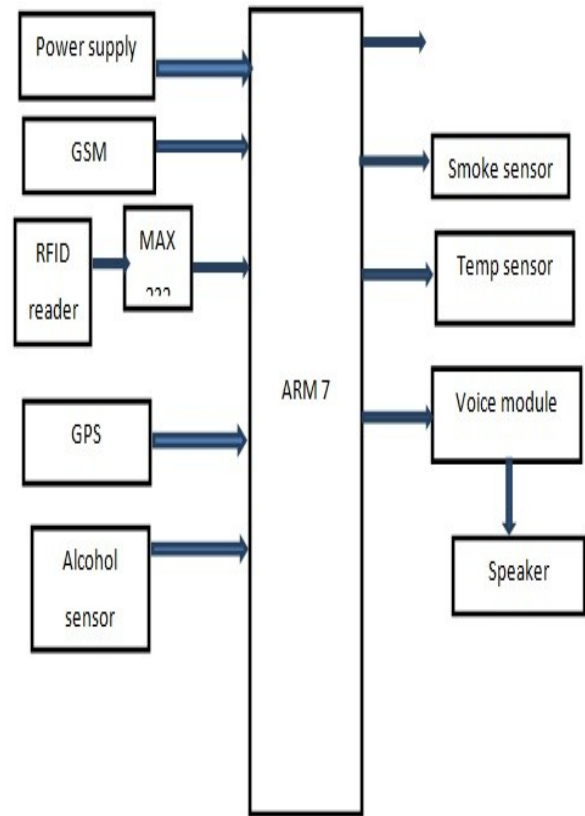

3.3 BLOCK DIAGRAM

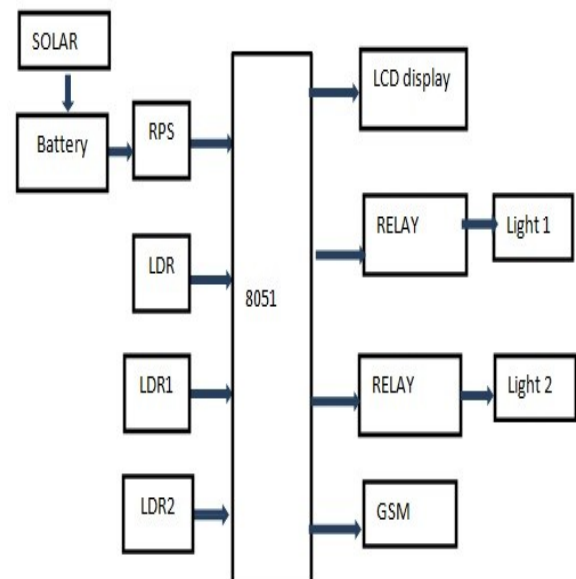

4.HARDWARE IMPLEMENTATION

4.1 ARM Microcontroller:

i) Micro Processor:

- 1.The C.P.U, memories, timers. Input/output ports, serial communication, interrupts etc., all these are located on different chips and are externally connected to the processing unit.
2. Different chips occupy more space; more power consumption is required and more cost.
3. Microprocessors are used in products like general purpose computers.
4. Different kinds of software applications can be loaded and can be used simultaneously.
5. Multitasking can be done using microprocessor.
6. The memory size, number of ports etc., can be configured according to the requirement in applications.
7. A large instruction set can be used for the applications using microprocessor.

ii) Microcontroller:

1. The central processing unit, serial communication, timers, Memories, interrupts, input/output ports etc., are equipped on the same single chip.
2. It occupies less space, so it consumes less power, and the cost also very low when compare to microprocessor.

3.Used for products that performs only a specified task.

4.Only a single software application is generally used.

5.Using microcontroller only a specified task can be done based on specified time periods.

6.The memory size, number of ports etc., are very limited.

7.A compact instruction or a reduced instruction set is generally used for the applications when use microcontrollers.

4.2 ADVANCED RISC MACHINE (ARM)

An ARM processor is one of a family of CPUs based on the RISC (reduced instruction set computer) architecture developed by Advanced RISC Machines (ARM).

ARM makes 32-bit and 64-bit RISC multi-core processors. RISC processors are designed to perform a smaller number of types of computer instructions so that they can operate at a higher speed, performing more millions of instructions per second (MIPS). By stripping out unneeded instructions and optimizing pathways, RISC processors provide outstanding performance at a fraction of the power demand of CISC (complex instruction set computing) devices.



ARM processors are extensively used in consumer electronic devices such as smart phones, tablets, multimedia players and other mobile devices, such as wearables. Because of their reduced instruction set, they require fewer transistors, which enable a smaller die size for the integrated circuitry (IC). The ARM processor's smaller size reduced complexity and lower power consumption makes them suitable for increasingly miniaturized devices.

SOME BASIC FACTS OF ARM:

ARM was founded by formerly known as ACORN RISC Machine founded by ACORN COMPUTERS LTD in 1983-85, later named as Advanced Risc Machine in 1990. ARM is basically a general purpose 32 bit processor.

ARM is incorporated with the 32 bit controllers manufactured by Philips with the banner name LPC series controllers. ARM family started with the series number from ARM 1, 2, 3, 4, 5, 6, 7, 8, 9, 10, 11, 12, 13. The series till ARM 6 were basically 16 bit microcontrollers. ARM 7 was the first 32 bit controller given by ARM. The even number of series was reserved for the company's R&D purpose and the odd version was released to the market for commercial purpose. ARM 10 is the only even series that was released to the market. Knowing the Nomenclature of ARM Family.

SOME BASIC FACTS OF ARM:

ARM was founded by formerly known as ACORN RISC Machine founded by ACORN COMPUTERS LTD in 1983-85, later named as Advanced Risc Machine in 1990. ARM is basically a general purpose 32 bit processor. ARM is incorporated with the 32 bit controllers manufactured by Philips with the banner name LPC series controllers. ARM family started with the series number from ARM 1, 2, 3, 4, 5, 6, 7, 8, 9, 10, 11, 12, 13. The series till ARM 6 were basically 16 bit microcontrollers. ARM 7 was the first 32 bit controller given by ARM.

The even number of series was reserved for the company's R&D purpose and the odd version was released to the market for commercial purpose. ARM 10 is the only even series that was released to the market.

Knowing the Nomenclature of ARM Family.

Microcontroller architecture:

1. Von Neumann Architecture (Princeton Architecture)

2. Harvard Architecture

Von Neumann architecture is used by a very large percentage of microcontrollers and here all memory space is on the same bus and instruction and data are treated identically. In the Harvard architecture, code and data, this allows code and

data to be fetched simultaneously, resulting in a more efficient implementation.

5. MODULES AND SENSORS

5.1 Global System for Mobile communications (GSM) Technology

Global System for Mobile communications (GSM) is the most popular standard for mobile phones in the world. GSM is considered a second generation (2G) mobile phone system. Data communication was built into the system from the 3rd Generation Partnership Project (3GPP).

GSM is a cellular network, which means that mobile phones connect to it by searching for cells in the immediate vicinity. GSM networks operate in four different frequency ranges. Most GSM networks operate in the 900 MHz or 1800 MHz bands. Some countries, including Canada and the United States, use the 850 MHz and 1900 MHz bands because the 900 and 1800 MHz frequency bands were already allocated. In the 900 MHz band the uplink frequency band is 890-915 MHz, and the downlink frequency band is 935-960 MHz. This 25 MHz bandwidth is subdivided into 124 carrier frequency channels, each spaced 200 kHz apart. Time division multiplexing is used to allow eight full-rate or sixteen half-rate speech channels per radio

frequency channel. There are eight radio timeslots (giving eight burst periods) grouped into what is called a Time Division Multiple Access (TDMA) frame. Half rate channels use alternate frames in the same timeslot. The channel data rate is 270.833 kbit/s, and the frame duration is 4.615 msec. The transmission power in the handset is limited to a maximum of 2 watts in GSM850/900 and 1 watt in GSM1800/1900.

There are four different cell sizes in a GSM network - macro, micro, pico and umbrella cells. The coverage area of each cell varies according to the implementation environment. Macro cells can be regarded as cells where the base station antenna is installed on a mast or a building above average roof top level. Micro cells are cells whose antenna height is under average roof top level and they are typically used in urban areas. Pico cells are small cells whose coverage diameter is a few dozen meters and they are mainly used indoors. Umbrella cells are used to cover shadowed regions of smaller cells and fill in gaps in coverage between those cells. Cell horizontal radius varies depending on antenna height, antenna gain and propagation conditions from a couple of hundred meters to several tens of kilometers. The longest distance the GSM specification supports in practical use is 35 km.

5.1.1 SIM900 GSM MODULE

Sim900 Overview

Designed for global market, SIM900 is a quad-band GSM/GPRS module that works on frequencies GSM 850MHz, EGSM 900MHz, DCS 1800MHz and PCS 1900MHz. SIM900 features GPRS multi-slot class 10/ class 8 (optional) and supports the GPRS coding schemes CS-1, CS-2, CS-3 and CS-4.

With a tiny configuration of 24*24*3mm, SIM900 can meet almost all the space requirements in user applications, such as M2M, smart phone, PDA and other mobile devices.

SIM900 has 68 SMT pads, and provides all hardware interfaces between the module and customers' boards.

Serial port and debug port can facilitate user without difficulty expand user's applications.

1. Audio channel which comprise a microphone input and a receiver output.
2. Programmable general reason input and output.
3. The keypad and SPI display interfaces will give users the suppleness to enlarge customized applications.

AT commands which are extremely useful for data relocate applications.SIM900 is designed with power saving method so that the contemporary conservation is as low as 1.0mA in

sleep mode.SIM900 is designed with power saving technique so that the present spending is as low as 1.0mA in sleep mode. SIM900 put together TCP/IP protocol and comprehensive TCP/IP SIM900 incorporate TCP/IP protocol and comprehensive TCP/IP AT commands which are extremely functional for data transfer applications

Sim900 Functional Diagram

The following figure shows a functional diagram of SIM900:

- The GSM base band engine
- Flash
- The GSM radio frequency part
- The antenna crossing point
- The other crossing point



Figure 5.1: SIM 009 Device

GSM Module

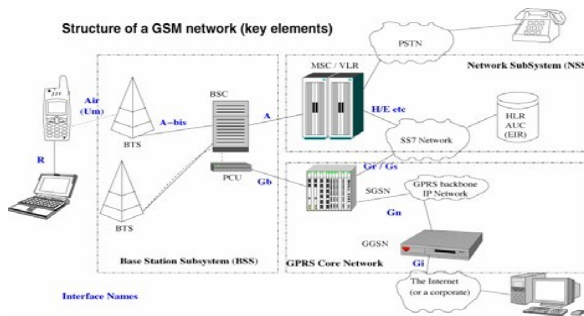

Figure 5.1.2: General structure of a GSM network

5.2 GPS

GPS (Global Positioning System) technology is used to find the location of any object or vehicle to monitor a child continuously using satellite signals. Three satellite signals are necessary to locate the receiver in 3D space and fourth satellite is used for time accuracy. GPS will give the information of parameters like longitude, latitude and attitude. With the help of these parameters one can easily locate the position of any object. In this GPS technology, the communication takes place between GPS transceiver and GPS satellite.

GPS receivers are used for positioning, locating, navigating, surveying and determining the time and are Employed both by private individuals (e.g. for leisure activities, such as trekking, balloon flights and cross-country skiing etc.) and companies (surveying, determining the time, navigation, vehicle monitoring etc.).

GPS (the full description is: Navigation System with Timing And Ranging Global Positioning System, NAVSTARGPS) Was developed by the U.S. Department of Defense (DoD) and can be used both by civilians and military Personnel. The civil signal SPS (Standard Positioning Service) can be used freely by the general public, whilst the military signal PPS (Precise Positioning Service) can only be used by authorized government agencies. The first satellite was placed in orbit on 22nd February 1978, and there are currently 28 operational satellites orbiting the Earth at a height of 20,180 km on 6 different orbital planes. Their orbits are inclined at 55° to the equator, ensuring that a least4 satellites are in radio communication with any point on the planet. Each satellite orbits the Earth in approximately 12 hours and has four atomic clocks on board During the development of the GPSsystem, particular emphasis was placed on the following three aspects

1. It had to provide users with the capability of determining position, speed and time, whether in motion or at rest.
2. It had to have a continuous, global, 3-dimensional positioning capability with a high degree of accuracy, Irrespective of the weather.
3. It had to offer potential for civilian use.



Fig 5.2.2. GPS satellite system

6. CONCLUSION:

In this project By using this, we can reduce the power consumption by switching ON and OFF the street lights when vehicle passing and to detect the failed lights. We can also alert the driver by giving prior information about the road signs .By this system we can alert the owner about the condition of vehicle by sending message alert through GPS and GSM.By this system it gives solution for transport related problems such as accident alert, vehicle surveillance, etc.. Some of these applications are implemented in some part of the globe. The scope of an intelligent RFID and sensors street light system is proposed and this could bring new opportunities for the researches. It is expected that with advancement in next generation RFID technology, the performance of various current applications will improve and also it may be made applicable in other areas.

7 .REFERENCES:

- [1] G. Varaprasad and R. S. D. Wahidabanu, "Flexible routing algorithmfor vehicular area networks," in Proc. IEEE Conf. Intell. Transp. Syst.Telecommun., Osaka, Japan, 2010, pp. 30–38.
- [2] B. P. Gokulan and D. Srinivasan, "Distributed geometric fuzzy multiagenturban traffic signal control," IEEE Trans. Intell. Transp. Syst.,vol. 11, no. 3, pp. 714–727, Sep. 2010.
- [3] K. Sridharamurthy, A. P. Govinda, J. D. Gopal, and G. Varaprasad,"Violation detection method for vehicular ad hoc networking,"Security Commun. Netw., to be published. [Online]. Available:
- [4] M. Abdoos, N. Mozayani, and A. L. C. Bazzan, "Traffic light control innon-stationary environments based on multi agent Q-learning," in Proc.14th Int. IEEE Conf. Intell. Transp. Syst., Oct. 2011, pp. 580–1585.
- [5] ZigBee Specifications, ZigBee Alliance IEEE Standard 802.15.4k2013,2014. [Online].
- [6] Traffic Congestion in Bangalore—A Rising Concern. [Online]. Available: <http://www.commonfloor.com/guide/traffic-congestion-in-bangalore-arising-concern-27238.html>, accessed 2013.
- [7] A. K. Mittal and D. Bhandari, "A novel approach to implement greenwave system and detection of stolen vehicles," in Proc. IEEE 3rd Int.Adv. Comput., Feb. 2013, pp. 1055–1059.
- [8] S. Sharma, A. Pithora, G. Gupta, M. Goel, and M. Sinha, "Traffic lightpriority control for emergency vehicle using RFID," Int. J. Innov. Eng.Technol., vol. 2, no. 2, pp. 363–366, 2013. [physics-green-city-traffic-smoothly.html](http://www.commonfloor.com/guide/physics-green-city-traffic-smoothly.html), accessed 2013.