

Comparative Study of Switching Null Subcarriers among Data-Subcarriers for PAPR Reduction in OFDM

More Amol Gopinath & Ravindra P. Shelkikar

(M.E. Scholar)¹, (Associate Professor)²

Electronics and Telecommunication Engineering Department^{1,2}

^{1,2}TPCT's College of Engineering, District-Osmanabad, (M.S.), India.

¹amolmore9086@gmail.com ²rpshelkikar@gmail.com

Abstract

Traditional single carrier modulation techniques can achieve only limited data rates due to the restrictions imposed by the multipath effect of wireless channel and the receiver complexity. High data-rate is desirable in many recent wireless multimedia applications. However, as the data-rate in communication system increases, the symbol duration gets reduced. Therefore, the communication systems using single carrier modulation suffer from severe intersymbol interference (ISI) caused by dispersive channel impulse response, thereby needing a complex equalization mechanism. Orthogonal Frequency Division Multiplexing (OFDM) is an attractive modulation technique for transmitting large amount of digital data over radio waves. High PAPR of the transmit signal is major drawback of OFDM. Proposed method promises PAPR reduction by shifting and switching null subcarrier with data subcarrier. When it is compared with existing reduction techniques (Such as Shifting Null Subcarrier among Data Subcarrier, Interleaving Technique, PTS, SLM, Tone rejection etc), the proposed method is compatible with current commercial system. The MATLAB simulation shows a PAPR reduction of around 1.4 dB using the proposed method than the existing methods also BER performance of proposed method is much better than that of existing methods. GUI also created to analyze the proposed work more efficiently.

Keywords: OFDM, PAPR, Switching Null Subcarriers, Data subcarriers.

1. INTRODUCTION

Communication by multicarrier modulation has in the recent years become a widely spread basis for data communication due to the high mobility that they allow. However wireless channels have some disadvantages like multipath fading and inter channel

interference (ICI). To overcome these disadvantages, concept of Orthogonal frequency division multiplexing (OFDM) has been invented which is known from 1966, but it only reached sufficient maturity for deployment in standard

systems during 1990s. The modulation that effectively deals with multipath fading is OFDM

[1]. As OFDM is a modulation technique splits the high rate data stream into N sub streams of lower data rate. The parallel systems divide the available bandwidth into N non overlapping sub channels. Each sub channel is modulated with a separate symbol and then the N sub channels are frequency multiplexed. Orthogonal Frequency Division Multiplexing (OFDM) [2] is an attractive modulation technique for transmitting large amount of digital data over radio waves [3, 4]. In single carrier system, if signal gets faded or interfered, then entire link gets failed, where as in a multicarrier system, only a small percentage of the subcarriers will be affected. It is very easy and efficient in dealing with multipath fading and robust against narrow band interference [5]. It has been widely adopted in many international standards, out of these standard IEEE 802.11a is used for proposed method.

This proposed scheme requires no channel side information (CSI) from the transmitter to the receiver, unlike some other PAPR-reduction approaches, such as selective mapping (SLM) and partial transmit sequences (PTS). Such channel side information would reduce the data-rate, and could significantly increase the bit error rate (if the channel side information is corrupted in transmission). This scheme does not distort the transmitted signal, unlike clipping. It also imposes no "rate hit", as the constellation remains unchanged at each data-subcarrier, unlike any coding-based PAPR-reduction method. This scheme is versatile, as it may be used simultaneously with any constellation-modifying PAPR-reduction scheme, such as active constellation extension, constellation shaping, partial transmit sequences (PTS), selective mapping (SLM), tone injection, trellis shaping. The proposed scheme is not a degenerate case of any constellation-modifying PAPR reduction scheme, because the proposed scheme does not affect the constellation at the data-subcarriers. The proposed scheme may be used simultaneously with other PAPR reduction methods that enlarge/contract/alter the

group of data-subcarriers, such as tone reservation (also known as peak-reduction carrier).

Following points can be considered for future work:

- (1) Investigate the trade-off between the computation load, BER performance, and other criteria.
- (2) Test and modify the methods proposed in Chapter II and Chapter III based on other international standards, like IEEE 802.16e, IEEE 802.15, IEEE 802.20, etc.

II. LITERATURE REVIEW

OFDM is a special case of multi carrier transmission, where a single data stream is transmitted over a number of lower rate subcarriers. In single carrier system, if signal gets faded or interfered, then entire link gets failed, where as in a multicarrier system, only a small percentage of the subcarriers will be affected. Most of the research is focused on the high efficient multicarrier transmission scheme based on "Orthogonal frequency" carriers. These carriers were mainly analog and generated using carrier bank, which was made up of the oscillators. The analog approach was very tough and it was not possible to have more number of subcarriers. It was also placing limitation on receiver design. H.Minn, et. al., [1] presented a robust symbol-timing and carrier-frequency synchronization method for OFDM systems in multipath fading environments has been presented. The proposed method uses one specifically designed training symbol having a steep roll off timing metric trajectory. This type of training symbol achieves some improvement in timing estimation for time-varying multipath Rayleigh fading channels and much more improvement in AWGN, Rician fading, and static dispersive channels. The channel estimation based on the designed training symbol is also incorporated to give further improvement in timing and frequency synchronization.

M. Sharif and B. Hassibi [2] remarked on the criteria for PAPR reduction technique selection and briefly address the problem of PAPR reduction in OFDM and MIMO-OFDM. CCU Wireless Access Tech. Lab [3] presented High peak-to-average power ratio of the transmit signal is a major drawback of multicarrier transmission such as OFDM or DMT. Ho Chin Keong [4] explained design considerations for OFDM design and criteria. A. Raniwala and T. Chiueh [5] proved that OFDM provides greater bandwidth efficiency, immunity to multi-path fading and impulse noise, resistance to frequency selective fading, and exemption from the need of complex equalizers and digital signal-processor hardware implementation. It has been widely adopted in the international standards which will be comfortable for OFDM signals for their operation.

R. DurgaBhavani, D. Sudhakar [7] presented inverse fast fourier transform (IFFT) and fast fourier transform (FFT), respectively. The IFFT/FFT algorithms are chosen due to their execution speed, flexibility and precision. For real time systems the execution speed is the main concern. The IFFT block provides orthogonality between adjacent subcarriers. The orthogonality makes the signal frame relatively secure to the fading caused by natural multipath environment. Orthogonal frequency division multiplexing (OFDM) provides better spectral efficiency than frequency division multiplexing (FDM), while maintaining orthogonal relation between carriers; hence traffic is better carried by OFDM than FDM within the same spectrum.

H. Zhang, et. al., [8] studied the peak transmit power is limited by either regulatory or application constraints, the effect is to reduce the average power allowed under multicarrier transmission relative to that under constant power modulation techniques. This in turn reduces the range of multicarrier transmission. Moreover, to prevent spectral growth of the multicarrier signal in the form of inter modulation among subcarriers and out-of-band radiation, the transmit power amplifier must be operated in its linear region (i.e. with a large input backoff), where the power conversion is inefficient.

A. Zaier and R. Bouallegue [9] the combination between the MIMO context and the OFDM system has stimulated mainly the evolution of the fourth generation broadband wireless communications. The simulation results have demonstrated the effectiveness of the approach for a 16 QAM modulation scheme and had been evaluated in term of bit error rate BER and mean square error MSE versus the signal to noise ratio SNR.

N. Chide, et. al. [10] developed carrier bank generating a set of subcarriers was necessary for OFDM in conventional or analogue approach. Each subcarrier was modulated with a constellation decided by bit combination, but this approach made system bulky and costlier. So to make system digital, simple, cheap, and efficient IFFT is being used. J. M. Kahn and Keang-P. H. [11] described increasing spectral efficiency is often the most economical means to increase DWDM system capacity. In this work, we have reviewed information-theoretical spectral efficiency limits for various modulation and detection techniques in both classical and quantum regimes, considering both linear and nonlinear fiber propagation regimes. Spectral efficiency limits for unconstrained modulation with coherent detection are several b/s/Hz in terrestrial DWDM systems, even considering nonlinear effects. Spectral efficiency limits are reduced significantly using either constant-intensity modulation or direct detection.

III. IMPLEMENTATION

3.1 Technique for PAPR Reduction

As discussed in Chapter II, different theoretical and hypotheses on determination of PAPR distribution have been reported and various schemes exist to reduce the PAPR. Various schemes could be categorized into “Distortion Based Technique” schemes or “Redundancy Based Technique” schemes. These techniques achieve PAPR reduction at the expense of increase in transmit signal power, increase in BER, increase in data rate loss, increase in computational complexity, distortion, channel side information etc.

The “Distortion Based Technique” schemes reduce high peaks by distorting the signal prior to amplification. Specific approaches include amplitude clipping, filtering, and companding. However “signal distortion” schemes could cause large in-band and out-of-band noise, resulting in system performance degradation i.e. the time domain signal are directly suppressed for which the power signal exceeds a certain threshold level.

The “Redundancy Based Technique” scramble each OFDM symbol with different scrambling sequences for the PAPR reduction i.e. number of candidate signals are generated and then selects the one candidate signal which will have lowest PAPR for actual transmission. Specific approaches includes partial transmit sequence (PTS) [22] and PTS using adaptive nonlinear estimator [23], selective mapping (SLM), interleaving, active constellation extension, tone reservation (TR), tone injection (TI), Null Switching method, Shifting Null subcarrier among Data subcarrier.

3.1.1 Clipping, Filtering and Peak Window

Power amplifier at transmitter, with saturation level below the signal span, automatically causes the signal to be clipped. Receiver needs to estimate two parameters of the transmitters clipping operation: location and size, which are difficult to get. Clipping [21] is one of the most simple and effective methods of PAPR reduction. In this method when the large peak that exceeds a certain threshold level value and occurs infrequently is clipped deliberately. The value of the threshold is chosen in such a way that it provides good PAPR reduction with less BER. Clipping is a nonlinear process and may cause significant in-band distortion that causes BER; out-of-band distortion causes degradation in spectral efficiency. Let the complex base band of signal is clipped such that the maximum absolute value of x is A that is $|x| = A$, taken absolute of each element of $|x|$ that is

$x_1, x_2, x_3, x_4, \dots, x_n$ and if any x 's exceeds A , it is clipped so that maximum absolute value of x 's is A .

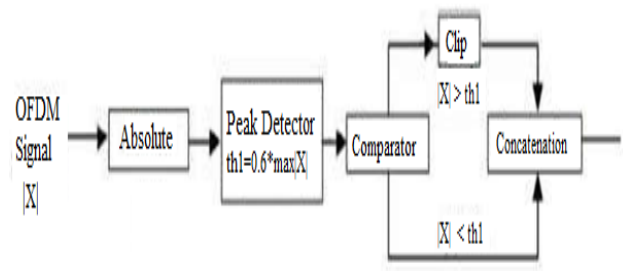

Figure 3.1 Block diagram of clipping method.

Clipping is accomplished by

$$x = A \quad \text{if } x > A \quad (4.1)$$

$$x = x \quad \text{if } x \leq A \quad (4.2)$$

After clipping let x be the received signal (assuming no addition of external noise) but due to clipping, there is certain bit error rate (BER).

$$\text{PAPR}^1 = \frac{\max\{|x|^2\}}{E\{x^2\}} \quad (4.3)$$

However, clipping introduces both in-band distortion like self interference and out-of-band radiation like nonlinear distortion into OFDM signals, which degrades systems BER and spectral efficiency.

3.1.2 INTERLEAVING TECHNIQUE

In interleaving approach, a set of interleavers is used to reduce the PAPR of multicarrier signal. An interleaver is a device that reorders data blocks. To make a set of modified data blocks, different interleavers are used to permit data blocks from the original data block. The modified data block with the lowest PAPR is then chosen for transmission. To recover the original data block, the receiver only needs to know which interleaver is used at the transmitter.

3.1.3 SELECTED MAPPING (SLM)

In the SLM technique, the transmitter generates a set of sufficiently different candidate data blocks by multiplying the same number of different phase sequences, all representing the same information as the original data block. The one with the lowest PAPR is selected for transmission. Information about the selected phase sequence should be transmitted to the receiver as side information.

SLM is a probabilistic technique for PAPR reduction with the aim of reducing the occurrence of peaks in a signal. In this method a set of candidate signals is generated. Before transmitting the signal, its PAPR is calculated and the one

with least value of PAPR is transmitted. The actual transmit signal lowest PAPR is selected from a set of sufficiently different signals which all represents the same information. SLM method is very flexible as they do not impose any restriction on modulation applied in the subcarriers or on their number, but the only disadvantage is increased computational complexity and increased overheads of side information. Let's data stream after serial to parallel conversion as $X = [X_0, X_1, \dots, X_n]^T$.

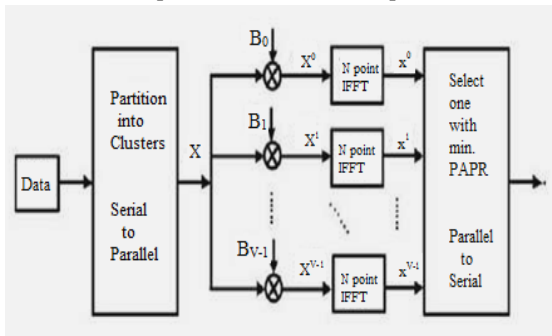

Figure 3.2 Block diagram of selected mapping method .

Initially each input X_n^v can be defined as equation

$$x_n^v = x_n * b_n^v \quad (4.4)$$

And B^v can be written as

$$x_n^v = [x_0^v, x_1^v, \dots, x_{N-1}^v] \quad (4.5)$$

Where $v = 0, 1, 2, \dots, V$ to make the V phase rotated OFDM data blocks. All V phased rotated OFDM data blocks represented the same information as the unmodified OFDM data block provided that the phase sequence is known. Output data of the lowest PAPR is selected to transmit. PAPR reduction effect will be better as the copy block U is increased. SLM method effectively reduces PAPR without any signal distortion but it has higher system complexity and computational burden.

The mean and variance of PAPR of the whole data block for normalized Riemann sequence set is very less compared to other phase sequence sets. Also, we can see from the above CCDF plots that use of normalized Riemann matrix as phase sequence vectors gives lower PAPR than Hadamard basis, Chaotic. So, the proposed technique of using normalized Riemann matrix as a phase sequence set outperforms.

3.1.4 TONE RESERVATION (TR)

TR method has also been proposed for PAPR reduction. The main idea of this method is to keep a small set of tones for PAPR reduction. This can be originated as a convex problem and it can be solved accurately. The amount of PAPR reduction depends on many factors such as number

of reserved tones, location of the reserved tones, amount of complexity and allowed power on reserved tones etc.

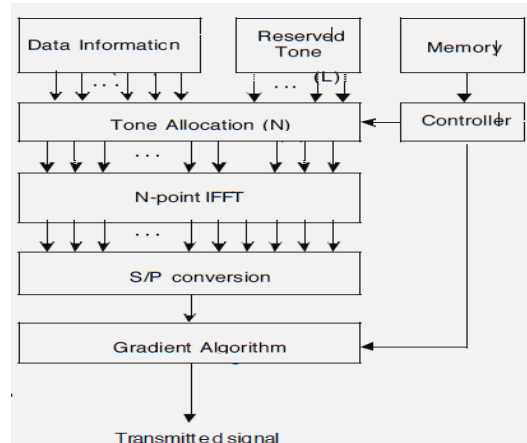

Figure 3.3 Block diagram of tone reservation method .

Figure 4.3 shows the structure of the OFDM system transmitter using proposed scheme. tones are reserved for PAPR reduction and tones are assigned for data information. All tones are allocated according to predetermined tone locations. Then IFFT [7] is executed and the gradient algorithm is operated. Introducing PSD constraints into tone reservation affects the achievable PAR reduction and significantly alters the complexity-versus-performance tradeoff for practical algorithms. The results in this work shows the impact that PSD constraints have on tone reservation performance, and it is clear that the effect when using randomly chosen tone sets is more severe than for contiguous tone sets.

3.4 802.11a STANDARD

Orthogonal Frequency Division Multiplexer provides greater bandwidth efficiency, immunity to multipath fading and impulse noise, resistance to frequency selective fading, and exemption from the need of complex equalizers and digital signal-processor hardware implementation. It has been widely adopted in the international standards.

Here we have used IEEE802.11a standard. An 802.11a OFDM carrier signal (burst type) is the sum of or more OFDM symbols each comprised of 52 orthogonal subcarrier with baseband data on each subcarrier being independently modulated using Quadrature Amplitude Modulation (available format BPSK, QPSK, 16QAM or 64 QAM). This composite baseband signal used to modulate a main RF carrier.

Following Figure 4.18 shows 802.11a OFDM signal generation process and Table 4.2 OFDM Physical Information.

Table 3.1 OFDM physical information

OFDM PHYSICAL INFO	
•	52 Subcarriers.
•	48 Data Subcarriers.
•	4 Pilot (-21,-7,+7,+21).
•	1 subcarrier = 1 constellation point.
•	312.5 KHz carrier separation.
•	BW 20 MHz, OBW 16.6MHz

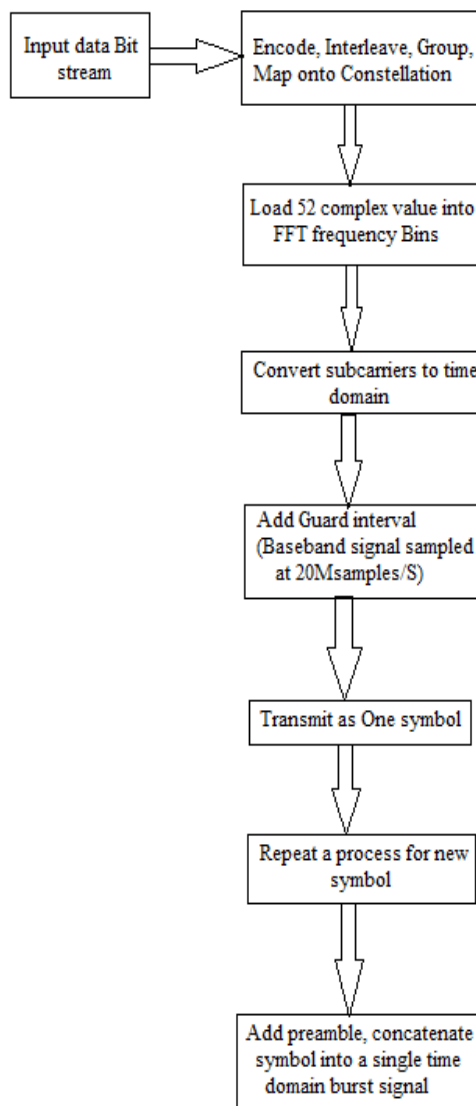

Figure 3.4 802.11aOFDM signal generation process

To begin the OFDM signal creation process, the input bit stream is encoded with convolutional coding and interleaving. Each data stream is divided into group of n bits.(1 bit BPSK, 2bits QPSK, 4 bits 16QAM or 6 bit 64 QAM) and convert into complex numbers (I+jQ) representing the mapped constellation point.

The bit rate will be different depending on the modulation format, a 64 QAM constellation (6 bit at a time) can have bit rate 54MBPS while a QPSK constellation (2 bits at a time) may be only 12MBPS. Then 52 subcarriers of the IFFT block are loaded. 48 subcarriers contain the constellation points which are mapped into frequency offset indexes ranging from -26 to +26, skipping the 4 pilot and Zero subcarriers. There are 4 pilot subcarriers inserted into frequency offset index location -21,-7,+7,+21. The zero subcarrier is the Null or DC subcarrier and is not used. It contains a 0 value (0+0j).

When the IFFT block is completely loaded, the IFFT computed and giving a set of complex time domain samples representing the combined OFDM subcarrier waveform. The samples are clocked out at 20 mega samples per second to create 3.2µs (20MSPS/64) duration OFDM waveform.

To complete the OFDM symbol, a 0.8µs duration guard interval (GI) is added to the beginning of the OFDM waveform. This produces a single OFDM symbol with a time duration of 4µs in length ie. (3.2µs + 0.8µs). This process repeated to create the additional OFDM symbols for remaining data bits.

To complete OFDM frame structure, the single OFDM symbols are concatenated together and then appended to 0.16µs preamble (used for synchronization) and a 4 µs signal symbol (provides rate and length information). This completes the OFDM frame and is ready to be transmitted as an OFDM burst.

3.4.2 Bit Error Rate and E_b/N_0

It is nothing but bit synchronization errors ie. firmly it will find the total number of errors between transmitted bit and received bit. This bit error rate is calculated by total number of bit errors divided by performance bits. This calculation is expressed in percentage.

For example 3 bits are encountered at receiver and 10 bits are transmitted then

$$BER = \text{Number of error bits} / \text{Number of transmitted Bits}$$

$$= 3/10$$

$$= 30 \%$$

In communication system, the receiver BER may be affected by transmission channel noise, interference, distortion, bit

synchronization problem, attenuation, and wireless multipath fading. These above problems are improved by choosing a strong signal strength (unless this cause cross talk and more bit errors), by choosing a slow and robust modulation scheme or line coding scheme and by channel coding scheme such as redundant forward error correction code.

E_b/N_0 is important parameter in DC or data transmission. It is normalized SNR measure, also known as SNR per bit. It is especially useful when comparing the BER performance of different digital modulation schemes without taking bandwidth in account. E_b is the signal energy associated with each user data bit; it is equal to the signal power divided by the user bit rate. If signal is in watts and bit rate is in bit per second. Hence it becomes joules (watt-second). N_0 noise spectral density, the noise power spectral density the noise power in a 1Hz bandwidth, measures in watts/ Hz ie. joules. It is dimensionless quantity and directly indicates the power efficiency of system without regard to modulation type, error correction coding or signal bandwidth. This also avoids any confusion as to which of several definition of bandwidth to apply to the signal. But when the signal bandwidth is well defined, E_b/N_0 is also equal to SNR in bandwidth divided.

E_b/N_0 's relation with SNR is

$$C/N = E_b/N_0 \cdot f_b/B$$

Where f_b is channel data rate and B is channel bandwidth.

IV. EXPERIMENTAL RESULTS AND ANALYSIS

Inherent in many multi-carrier standards are null-subcarriers (a.k.a., virtual/unused/unmodulated subcarriers), where no energy is transmitted.

For example, in the IEEE 802.11a/g standard .

i) 6 null-subcarriers serve as guard-band at the low-frequency end and 5 null-subcarriers serve at the high-frequency end as guard-bands.

ii) A mid-band null subcarrier (indexed 0) for accommodating low cost RF-filter that avoids delay of DC energy.

In the IEEE 802.11a standard, using some of the "innermost" null subcarriers in the guard-band is sometimes tolerable because the spectral mask has its transition-band over those null subcarriers, thereby passing a good portion of the energy in these "innermost" null subcarriers as shown in Figure 4.1. for inclusion of null-subcarriers.

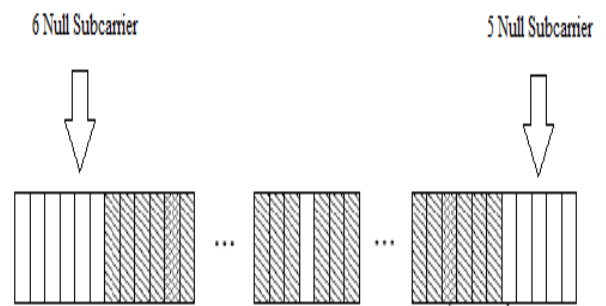

□ Null Subcarrier ▨ Data subcarrier **Figure 5.1** Spectral mask

4.1 Proposed Method's Underlying Philosophy

This proposed scheme shifts and switches one or more null-subcarriers to be identified data subcarrier(s). This changes the input to the IFFT operator, and thus the IFFT operators [7] output and its PAPR.

The guard-bands of many multi-carrier standards (e.g. IEEE 802.11a/g) have null-subcarriers in the transition-band of the transmit spectrum mask (i.e. the bandpass filter matched to the desired users data-subcarriers). Hence, such a null-subcarrier frequency can pass a good portion of any energy therein onto the receiver.

For the above shifting and switching, the transmitter is to search for the data-subcarrier that (when switched with a null-subcarrier) would achieve the greatest PAPR-reduction.

4.2 The Proposed Algorithm

Consider OFDM transmission splits the high rate data stream into S sub streams of the lower data rate i.e. parallel system divide the available bandwidth into S non overlapping subchannels with ascending frequencies set $\{f_s, s = 1, 2, \dots, S\}$. the total S subcarriers are the combination of data subcarriers (D) and null subcarriers (N), where for N ascending frequency set $\{f_n, n = 1, 2, \dots, N\}$ and for D ascending frequency set $\{f_d, d = 1, 2, \dots, S - N\}$.

Moreover, $f_n \neq f_d, \forall n, d$. Assigned to the data subcarriers at $\{f_d, 1 \leq d \leq S - N\}$ are, respectively, the M-ary data symbols $\{x_d, d = 1, \dots, L - N\}$, taken from a quadrature amplitude modulation (QAM) constellation.

Null Switching Method

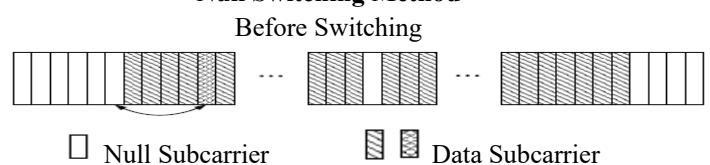

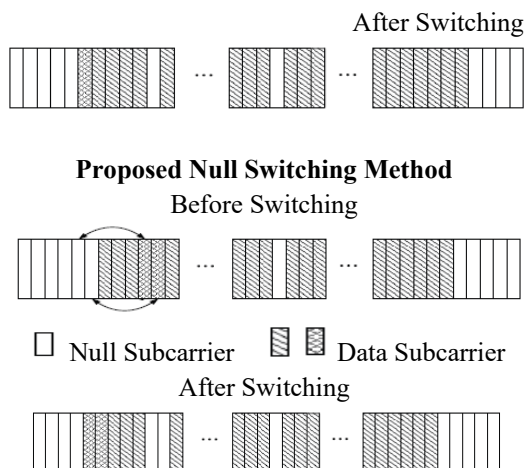

Figure 4.2 Comparison between null switching method and proposed null switching method

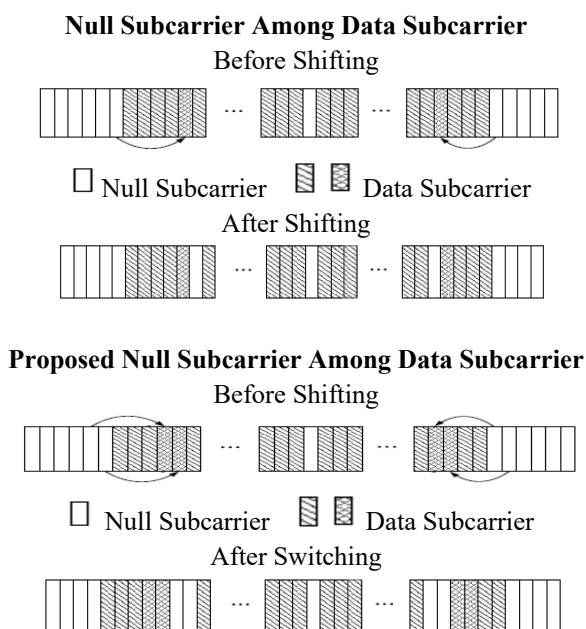

Figure 4.3 Shifting null subcarrier among data subcarrier and proposed shifting null subcarrier among data subcarrier

From Figure 5.2 and 5.3, without changing the values of total subcarrier, data subcarrier and null subcarrier, we need to shifts P elements to generate number of candidates and then selects one candidate which will have lowest PAPR for transmission. For finding shifting possibilities we can derive using

$$\frac{S-N}{P} = \frac{(S-N)!}{P!(S-N-P)!} \quad (4.1)$$

The designing of null subcarrier in standard is at low frequency end is one more than that at high frequency end when shifting element is even and vice versa. Proposed

method requires low CSI, for maintaining the synchronization between transmitter and receiver which helps to recover data subcarrier as in its original form i.e. sequencing back to original format which were changed due to various shifting to get one of the candidate which having lowest PAPR. Here two proposed methods are derived from existing reduction techniques which shown in figure.

For the IEEE 802.11a standard, the number of null-subcarriers as guard-bands at low frequency end is one more than that at high-frequency end, if P is even; the number of null-subcarriers as guard-bands at low-frequency end equals to that at high-frequency end, if P is odd.

The flow chart for proposed method is given Figure 4.4.

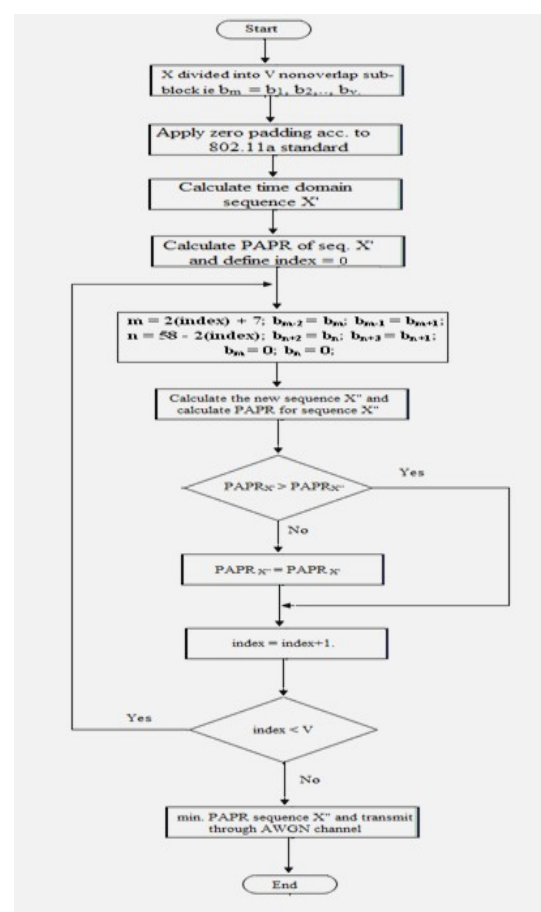

Figure 4.4 Flow chart for proposed method

V.SIMULATION RESULTS

The IEEE 802.11a standard with AWGN channel model is used here as an example, even though the proposed scheme could be used with any multi-carrier system with null-subcarriers. The standard find out appropriate candidate which has minimum PAPR after reshuffling of null subcarrier and data sunbarrier. An 802.11a OFDM carrier signal (burst type) is the sum of one or more OFDM

symbols each comprised of 52 orthogonal subcarriers with baseband data on each subcarrier being independently modulated using 16-QAM. To minimize any degradation to the guard-band, various methods are used and Figure 4.5 shows the analysis result to degrade PAPR. Due to applied various methods whether it affects on receiving data (by checking error rate) for this

Figure 4.6 shows whether BER calculations for various methods.

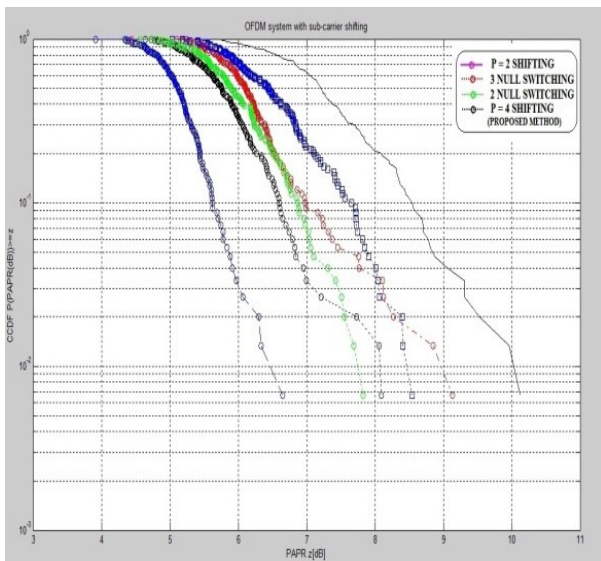

Figure 5.5 The PAPR's CCDF @ $p = 2$ [1], switching by 3 & 2 null subcarrier, null switching and $p = 4$.

Figure 4.5 shows the PAPR values of various reduction techniques, here proposed null switching method i.e. 2-null switching (≈ 7.8 dB) is better than Null switching method i.e. 1-null switching (≈ 8.5 dB) based on same computational complexity also graph shows proposed shifting null subcarrier among data subcarrier method i.e. $p = 4$ (≈ 6.7 dB) is better than shifting null subcarrier among data subcarrier method i.e. $p = 2$ (≈ 9.2 dB) [25]. Comparing all methods, Shifting Null Subcarrier among Data Subcarrier Method is better than other methods. Figure 4.6 shows that the BER performance of proposed null subcarrier among data subcarrier method (≈ 14.8 dB) is close to that of Shifting at $p = 2$ (≈ 15.3 dB) [25]. But when comparing both with proposed null switching i.e. 2-null switching (> 15.3 dB) is not better one. As we have seen in Figure 4.5 PAPR performance of proposed Null switching method i.e. 2-null switching is better than Null switching method i.e. 1-null switching and shifting null subcarrier among data subcarrier method i.e. $p = 2$ [25]. But in case of BER performance is not good as shown in Figure 4.6.

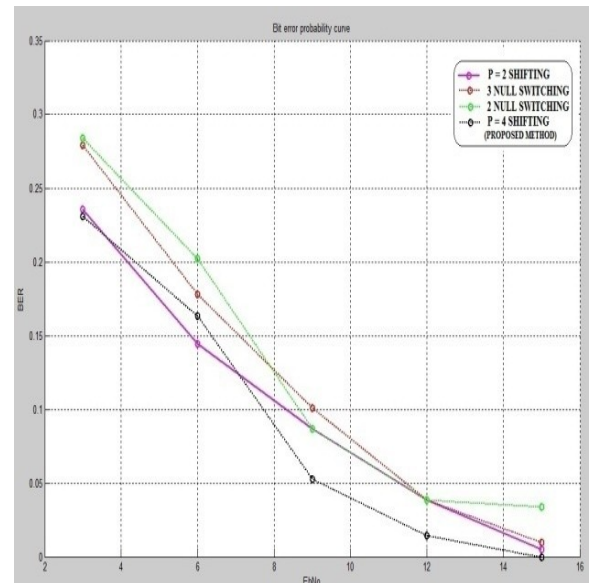

Figure 5.6 BER against SNR $A_{\gamma} = 3$ dB with $p = 2$ [25], switching by 3 & 2 null subcarrier and $p = 4$.

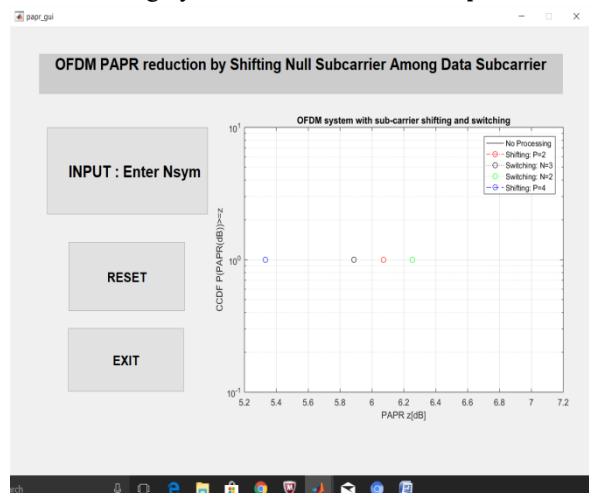

Figure 5.7 GUI for analysis of proposed work for $N_{sym} = 1$ and sifting and switching

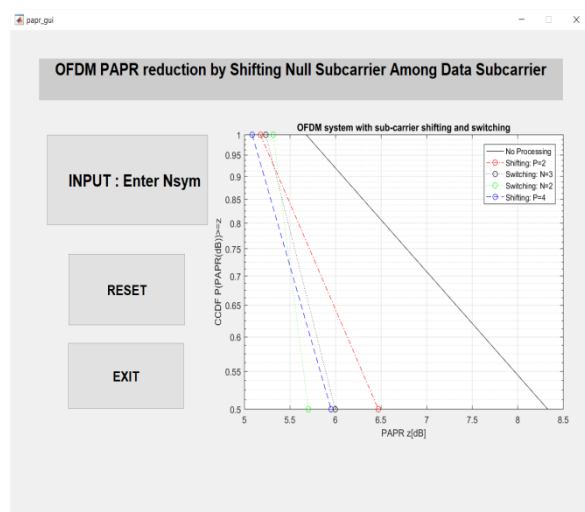

Figure.5.8 GUI for analysis of proposed work for Nsym=2 and sifting and switching.

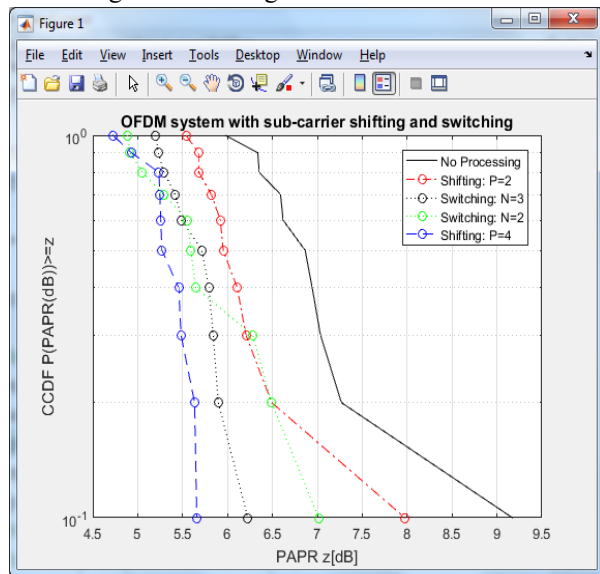

Figure.13 CCDF Performance of OFDM with nsym=10,with subcarrier shifting and switching

Table 1: Comparison table for CCDF Performance of OFDM with nsym=10,with subcarrier shifting and switching.

S.no	CCDF P(PAPR(db))	PAPR(db)				
		No Processing	Shifting P=2	Switching N=3	Switching N=2	Shifting P=4
1	0.1	9.2	8	6.3	7	5.7
2	0.2	7.3	6.5	5.8	6.5	5.6
3	0.3	7	6.2	5.7	6.3	5.5
4	0.4	6.8	6.1	5.65	5.7	5.4
5	0.5	6.7	5.9	5.6	5.6	5.25
6	0.6	6.6	5.8	5.5	5.55	5.25
7	0.7	6.6	5.7	5.4	5.3	5.25
8	0.8	6.3	5.6	5.3	5.1	5.25
9	0.9	6.3	5.6	5.25	4.9	4.9
10	1	6	5.5	5.2	4.8	4.8

From the above comparative table, there is very less PAPR for shifting (P=4) for a given number of subcarriers

VI. CONCLUSIONS AND FUTURE SCOPE

To reduce the PAPR of multicarrier transmission, we propose new scheme by reordering the null subcarriers and data subcarriers. In this method, the null subcarriers and data subcarriers are shifted to achieve minimum PAPR. This method is distortionless, does not affect the constellation at

the data subcarriers, maintains better PAPR reduction and BER reduction performance while keeping low computational complexity, needs less CSI and can be compatible with existing standard. “Null switching” methods need very high computational complexity when the number of subcarriers is large. Although this method remove the need of CSI, the BER performance is not good enough when the signal-to-noise ratio is low. Here, proposed scheme has “Reduced-complexity” version by shifting some of the “innermost” null subcarrier(s) in the guard-band among data subcarriers to minimize the PAPR at the transmitter, possessing better BER performance and low computational complexity.

This proposed scheme requires no channel side information (CSI) from the transmitter to the receiver, unlike some other PAPR-reduction approaches, such as selective mapping (SLM) and partial transmit sequences (PTS). Such channel side information would reduce the data-rate, and could significantly increase the bit error rate (if the channel side information is corrupted in transmission). This scheme does not distort the transmitted signal, unlike clipping. It also imposes no “rate hit”, as the constellation remains unchanged at each data-subcarrier, unlike any coding-based PAPR-reduction method. This scheme is versatile, as it may be used simultaneously with any constellation-modifying PAPR-reduction scheme, such as active constellation extension, constellation shaping, partial transmit sequences (PTS), selective mapping (SLM), tone injection, trellis shaping. The proposed scheme is not a degenerate case of any constellation-modifying PAPR reduction scheme, because the proposed scheme does not affect the constellation at the data-subcarriers. The proposed scheme may be used simultaneously with other PAPR reduction methods that enlarge/contract/alter the group of data-subcarriers, such as tone reservation (also known as peak-reduction carrier). GUI (graphical user interface) is created to analyze system more efficiently.

REFERENCES

- [1] H. Minn, V. K. Bhargava, and K. B. Letaief, “A robust timing and frequency synchronization for OFDM systems”, *IEEE Transactions on Wireless Communications*, vol. 2, no. 4, pp. 822-839, 2003.
- [2] M. Sharif and B. Hassibi, “On the capacity of MIMO broadcast channels with partial side information”, *IEEE Transactions on Information Theory*, vol. 51, no. 2, pp. 506-522, 2005.
- [3] *The Basic Principles of OFDM*, CCU Wireless Access Tech. Lab.
- [4] H.C. Keong, *Overview on OFDM design*, Communication Systems & Signal Processing

Centre for Wireless Communications, National University of Singapore 2001.

- [5] A.Raniwala and T.Chiueh, *Architecture and algorithms for an iee 802.11-based multi-channel wireless mesh network*, Computer Science Department, Stony Brook University, Stony Brook, NY.
- [6] http://en.wikipedia.org/wiki/Orthogonal_frequency-division_multiplexing
- [7] R. DurgaBhavani and D.Sudhakar, “Design and implementation of inverse fast fourier transform for OFDM”, *International Journal of Science and Engineering Applications*, vol.2, pp. 155-158, 2013.
- [8] H. Zhang, D.L.Ruyet, M.Terre, *Spectral efficiency analysis in ofdm and OFDM/OQAM based cognitive radio networks*, Electronics and Communications Laboratory, CNAM Paris, France.
- [9] A. Zaier and R. Bouallegue “Blind channel estimation enhancement for MIMO- OFDM systems under high mobility conditions”, *International Journal of Wireless & Mobile Networks (IJWMN)*, vol. 4, no. 1, pp. 207-214, 2012.
- [10] N.Chide, S.Deshmukh, Prof. P.B. Borole, “Implementation of OFDM system using IFFT and FFT”, *International Journal of Engineering Research and Applications*, vol. 3, pp.2009-2014, 2013