

Fuzzy Logic Based Algorithm for Clustering In Wsn to Extend the Network Lifetime

K.Sreelasya & Dr. S.Jhansi Rani

¹M.Tech, Department of Computer Science and Systems Engineering, Andhra University College of Engineering, Visakhapatnam, Andhra Pradesh, India.

²Professor, Department of Computer Science and Systems Engineering, Andhra University College of Engineering, Visakhapatnam, Andhra Pradesh, India.

Abstract : *Wireless sensor Network (WSN) brings a new paradigm of real time embedded systems with limited computation, communication, memory, and energy resources that are being used for huge range of applications where traditional infrastructure based network is mostly infeasible. The sensor nodes are densely deployed in a hostile environment to monitor, detect, and analyze the physical phenomenon and consume considerable amount of energy while transmitting the information. It is impractical and sometimes impossible to replace the battery and to maintain longer network life time. So, there is a limitation on the lifetime of the battery power and energy conservation is a challenging issue. Appropriate cluster head (CH) election is one such issue which can reduce the energy consumption dramatically. Low Energy Adaptive Clustering Hierarchy (LEACH) is the most famous hierarchical routing protocol, where the CH is elected in rotation basis based on a probabilistic threshold value and only CHs are allowed to send the information to the base station (BS). But in this approach, a super cluster head (SCH) is elected among the CHs who can only send the information to the mobile BS by choosing suitable fuzzy descriptors such as remaining battery power (RBP), Mobility of BS and Centrality of the clusters. Fuzzy inference engine (Mamdani's rule) is used to elect the chance to be the SCH. The results have been derived from NS-2 simulator and shows that the proposed protocol performs better than LEACH protocol in terms of First node dies, Half node alive, better stability and better lifetime.*

Keywords: WSN, SCH, Fuzzy logic.

1. INTRODUCTION

Wireless Sensor Network considered as real time embedded system deployed in a particular region to sense various types of environmental parameters such as temperature, pressure, gas, humidity etc. The huge applications of WSN like habitat monitoring, forest fire detection, surveillances, transport monitoring etc. have created a lot of interest among the researcher community in recent past. Typically, WSNs are densely deployed in hazardous places where battery recharge or replacement is nearly impossible and human monitoring scheme is highly risky. There are many typical issues such as power constraints, limited computing capacity, open environment; radio connectivity makes the sensor nodes faulty many times. Once the network is established, nodes keep on sensing the information and the battery power goes exponentially.

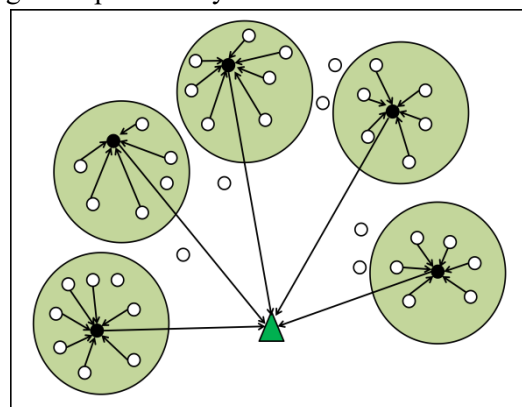

Figure 1: General System Model for WSN

Whenever the nodes detect any event, they send the information to the other nodes or to the base station.

Sometimes it happens that the same information received by nearby sensor nodes can be received by the base station that makes the network inefficient. To avoid this data redundancy and to make the network most energy efficient, data aggregation and sensor fusion have been emphasized in the literature. Many routing protocols with many different ideas have been proposed in the literature to make the network energy efficient. Cluster based routing protocol is one of these efficient ideas, where sensor nodes are divided into number of groups and each group is called as a cluster. One group leader is elected in each cluster known as Cluster Head (CH). Data aggregation is obtained at the leader node. The leader node/CH is only responsible for sending the message to the BS. Figure 1 shows the general system model for clustering based WSN.

2. RELATED WORK

In this section, most of the well-known hierarchical routing protocols are discussed where the cluster heads are elected in an energy efficient manner. We have also focused on some fuzzy logic based clustering protocols. Each cluster head is the representative for the respective cluster for gathering the information from other nodes and send to the base station either directly or indirectly. Even though many clustering protocols with fuzzy or without fuzzy descriptors are proposed, very few most important protocols are presented here.

A. Hierarchical Routing Protocols based on clustering

1) LEACH

LEACH [1,2] is a hierarchical routing protocol which elects CHs based on probabilistic model and each sensor node has equal chance to become a CH. This protocol operates in two phases. These are set up phase and steady state phase. In set up phase, nodes form the cluster and actual data is transmitted in the steady state phase. Each node chooses a random number between 0 and 1 to become the CH. If the number is less than the threshold value $T(n)$, the node gets the chance to be the cluster head for the current round. The threshold value $T(n)$ is defined in equation

$$T(n) = \begin{cases} \frac{p}{1-p*(r \bmod \frac{1}{p})}, & \text{if } n \in G \\ 0, & \text{otherwise} \end{cases} \quad (1)$$

is the round which already ended, p is the

probability of the nodes to be the CH, G is a set of nodes which have never been cluster head in the last $1/p$ rounds.

Although LEACH protocol distributes the load equally on each cluster head, still there are some pitfalls that need to be addressed.

These are:

- There is no guarantee that preferred number of CHs is elected in each round.
- LEACH uses probabilistic model to decide Cluster Head. So there is a possibility that two cluster heads are elected which is closed to each other, that tends to deplete over all energy in the network.
- More CPU cycles are consumed because in each round, one random number is generated and threshold value is calculated.
- If the elected node is located near to the boundary of the network, other nodes could dissipate more energy to transfer the message to CH.

2) LEACH-C

In LEACH-C [2] CH is elected by the BS using a centralized algorithm. BS knows the location information and energy of each node. So, it can produce better clusters by dispersing Cluster Head nodes throughout the network. The main

drawback of this centralized protocol is that the position of all the nodes must be known. In [3-8], many clustering protocols have been discussed. As we are interested on fuzzy logic based clustering protocols, few of them are highlighted below.

B. Fuzzy Logic based Clustering Protocol

Many researchers have come up with many different ideas how Fuzzy Logic (FL) can be utilized to elect the proper and efficient CH so that substantial life time can be accomplished. Some of the well-known FL based clustering algorithms have been discussed below.

1) CHEF

In CHEF [4] CH is elected based on two parameters which are proximity distance and energy. The fuzzy based approach elects the node to be the CH with high energy and locally optimal node. Simulation

result shows that the CHEF is 22.7% more efficient than LEACH. In [3], the author has considered three fuzzy parameters such as energy, concentration, and centrality. These three parameters are the key points to calculate the chance to be the CH which can improve the network life time. Energy level is defined as available energy at each node, concentration is number of neighbor nodes and centrality is a value based on how central the node to the cluster. But the main drawbacks with this protocol are that all the nodes are not equipped with GPS receivers and they might not be able to provide location information in some places.

2) F-MCHEL

In F-MCHEL [7] CH is elected by applying fuzzy rules based on energy and proximity of distance. The node which has

the maximum residual energy among the cluster heads is selected as a Master Cluster Head (MCH) and sends the aggregated data to the base station. F-MCHEL is an improvement of CHEF. It provides more network stability as compared to LEACH and CHEF. In F-MCHEL, base station has been considered as static. In [9-12] many protocols have been discussed based on fuzzy techniques. In [15], we proposed a protocol which considers three fuzzy parameters such as remaining battery power, mobility, and distance to base station to elect a SCH. but the major drawbacks of this protocol is that when mobility increases or decreases, the lifetime of the network remains constant. Because, mobility indirectly proportional to the distance to base station. To overcome this problem, Centrality has been considered as the third input parameter for the fuzzification module in this proposed protocol. From the simulation results it is believed that the proposed protocol is stable and would be applicable in large scale for WSN applications.

3. ENERGY MODEL ANALYSIS

Figure 2 shows the radio model which has been referred from [6]. The amount of energy consumed from the transmitter to the receiver for l bits to a distance d during transmission and reception is given in equation 2.

$$E_{Tx}(l, d) = E_{Tx-elec}(l) + E_{Tx-amp}(l, d)$$

$$= \begin{cases} l * E_{elec} + l * \epsilon_{fs} * d^2 & \text{if } d < d_0; \\ l * E_{elec} + l * \epsilon_{mp} * d^4 & \text{if } d \geq d_0; \end{cases} \quad (2)$$

- E_{elec} represents the energy dissipated per bit to run the transmitter or the receiver circuit. It depends on the factors like digital coding, modulation, filtering and spreading of the signal.
- are the characteristics of the transmitter Amplifier which is used for free space and Multipath.

for

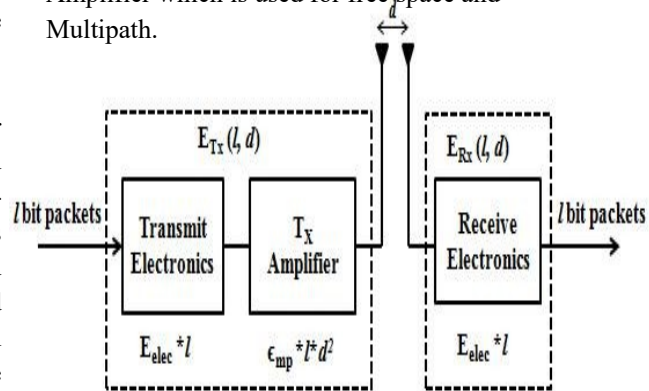

Figure 2: Radio Model

As the distance between transmitter and receiver is less than the threshold value d_0 , the free space model (d^2 power loss) is used. Otherwise, the multipath fading channel model (d^4 power loss) is used. Power control can be used to invert this loss by appropriately adjusting the power amplifier. The equation 3 shows the amount of energy consumption to receive l bit of data while equation 4 represents the threshold value which is the ratio ϵ_{fs} and ϵ_{mp}

$$E_{Rx}(l) = E_{elec} * l(3) \quad d_0 = \sqrt{(\epsilon_{fs} / \epsilon_{mp})}(4)$$

4. PROPOSED SYSTEM

We have also focused on some fuzzy logic based clustering protocols. Each cluster head is the representative for the respective cluster for gathering the information from other nodes and send to the base station either directly or indirectly. Even though many

clustering protocols with fuzzy or without fuzzy descriptors are proposed, very few most important protocols are presented here.

Fuzzy Logic is used to model human experience and human decision making behavior. Further, it can handle uncertainties of real time applications more accurately than the probabilistic model. FL is adopted in this technique in order to handle the uncertainties for electing the SCH. The major benefit of using FL is to overcome the overheads of collecting and calculating energy and location information of each node. Most of the FL based clustering algorithms consider the sink node/BS as static. Now there is a trend to investigate sink or BS mobility that can relieve the network traffic, reduces delay and enhances energy efficiency. We also assumed that the sink or BS will move in a specific pattern specified in the protocol. Finally, through the simulation results it has been shown that the proposed approach performs better than LEACH protocol.

A. System Assumption

In the proposed model, sensor nodes are considered to be deployed randomly to monitor the environment continuously.

- 1) All the sensor nodes are static except the base station
- 2) The base station is mobile
- 3) Homogeneous networks have been considered such that all the sensor nodes have initial equal energy.
- 4) The distance between the node and the base station can be computed based on received signal strength

B. System Model

The proposed clustering method follows the basic principle of LEACH. The cluster is formed in each round. In every clustering round, each node generates a random number between 0 and 1. If the random number for a particular node is bigger than the threshold value T , the node becomes the CH. In basic LEACH, the cluster formation algorithm was defined to ensure that the no. of cluster per round is k , a system parameter.

The optimal value of k (*koptimal*) in LEACH can be determined analytically by computation and

communication energy model. For instance, if there are N nodes distributed randomly over $M \times M$ region, and k clusters are assumed, then there are N/k nodes per cluster (one CH and $(N/k)-1$ Non Cluster head nodes. Each CH dissipates energy by receiving the signal, aggregates it and sends the average signal to BS.

It is assumed that sensor nodes send the data after detecting an interesting event. CH collects these data, aggregates it and send to the base station. To save some energy, we may think of one SCH among the CHs can send the data to BS to utilize the bandwidth efficiently. Instead of multiple CHs, one SCH can deliver the message to BS that can reduce energy consumption and enhances energy efficiency. The proposed model is depicted in Figure 3. Another assumption we have made the BS mobility that can relax collision avoidance by collecting the data from SCH. Other sensor nodes including CHs and SCH remain static. Base station may adopt many different paths to collect the information from the SCH as shown in Figure 4. Further assumption we have made that *Remaining battery power, Mobility, and Centrality*: the three fuzzy descriptors are suitable to calculate the chance to be the SCH that can deliver the message to the BS. Assuming that in each round energy level of each CH gets reduced, remaining battery power has been considered as a metric. Centrality is considered as another major metric because centrality focuses on the location of SCH how much it is positioned centrally to communicate with other CHs. Mobility implies that when BS moves in a particular direction, the distance between BS and SCH increases or decreases w.r.t to the speed and direction of moving BS.

The Proposed Algorithm

/ for every round */*

1. Select CHs based on threshold value.
2. Select $k_{optimal}$ CHs in each round.
3. Select SCH based on fuzzy if-then rules from the CHs.

/ for $k_{optimal}$ CHs */*

4. All CHs sends the aggregated data to SCH

/ end of for */*

5. BS collects the information from SCH

/ end of rounds */*

C. Fuzzy Logic Model

The Fuzzy logic model consists of four modules: a fuzzifier, fuzzy inference engine, fuzzy rules and a defuzzifier. The most widely used fuzzy method Mamdani Method [13] is used here. The block diagram of the Fuzzy Inference

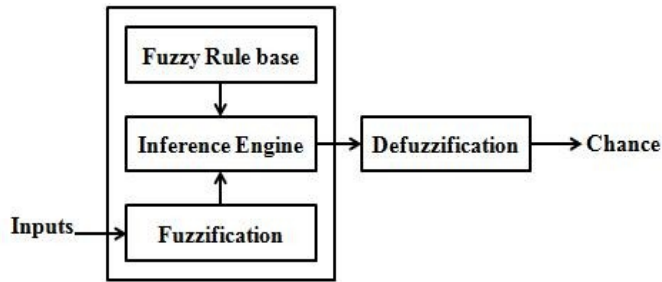

Figure 3: Fuzzifier Logic

System is shown in Figure 3. There are four steps required to complete the process.

1. Fuzzification: In fuzzifier, inputs are given with crisp value and changed into a fuzzy set. This can be achieved by fuzzification.
2. Rule evaluation: It stores IF-THEN rule.
3. Fuzzy Inference Engine: This engine takes both the input values and IF-THEN rules to simulate the reasoning by which it produces a fuzzy inference.
4. Defuzzification: Defuzzifier transforms the fuzzy set into a crisp value.

1. Fuzzification Module

In our proposed protocol, Mamdani's Method Fuzzy Inference technique is used to elect the SCH as it is the most frequently used inference technique. The inference techniques and the Fuzzy system used for our proposed

model are given in Figure 6. We have taken three fuzzy input variables to elect the tentative Super Cluster Head. All the three input variables have three membership functions each. The fuzzy set that represents the first input variable i.e. remaining battery power is depicted in Figure (7). The linguistic variables

for the fuzzy set is less, medium and high. Trapezoidal membership function has been considered for less and high. For medium, triangular membership function has been considered.

The second fuzzy input variable is the Mobility of the base station because the proposed protocol considers the base station as mobile. The linguistic variables for mobility are taken as low, moderate, and frequent. The fuzzy set for mobility is depicted in Figure 4. The third fuzzy input variable is the centrality that how much the SCH is central to other clusters. The linguistic variables for centrality are considered as close, adequate, and far. The fuzzy set for centrality is shown in Figure 4. Table 1 shows the Membership functions of all the input variables. The degree of the membership function is shown by a numerical after each membership function.

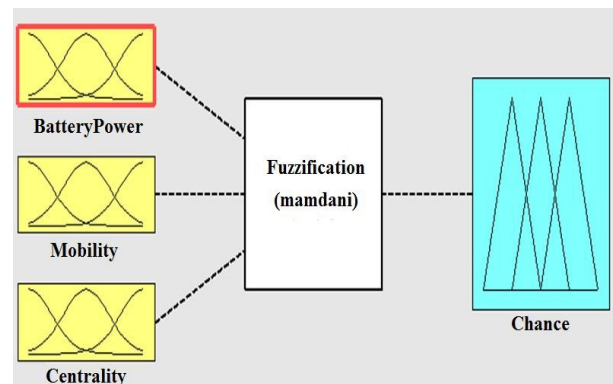

Figure 4: Fuzzy system for proposed model.

2. Rule Based and Inference Engine

In our system, we have used 27 rules in the fuzzy inference. The form of the rules is if X, Y, Z then C. X represent remaining battery power, Y represents mobility, Z represents the centrality, and C represents

the chance. The rules are derived from the formula which is given in equation

$$\text{Chance} = (\text{battery} - 1) + \text{Centrality} + \text{Mobility} \quad (5)$$

In this equation, we have considered remaining battery power as $(\text{Battery Power} - 1)$ because in each round there will be some energy consumption at each node. So, after processing of each round, the remaining

energy is considered for the next round. Mobility and Centrality is assumed to be additive factor why because the distance of SCH from base station increases or decreases with respect to the movement of base station. When SCH delivers the message to BS how much it is central to other clusters to deliver the message. As discussed above, the output variable chance of a node for getting elected as a SCH is calculated using remaining battery power, mobility of base station, and centrality of the clusters. The output chance is composed of 7 membership functions *very weak*, *weak*, *lower medium*, *medium*, *higher medium*, *strong*, *very strong*. The fuzzysset for chance is depicted.

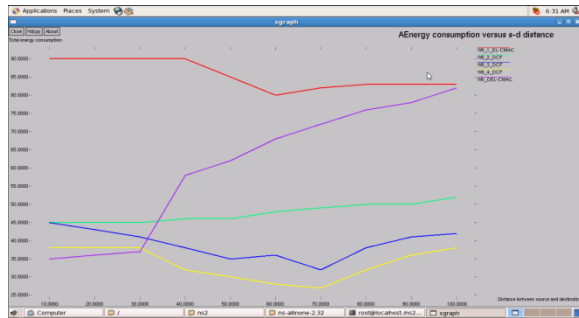

Figure 5: Energy consumption graph

As the distance between source and destination (Figure 5) increases, the energy consumption also increases.

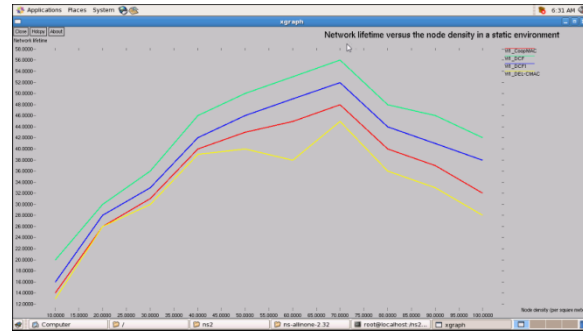

Figure 6: Network lifetime vs. node density

As the node density increases (Fig 6), the network lifetime will increase and at one point will gradually decrease because of the nodes life

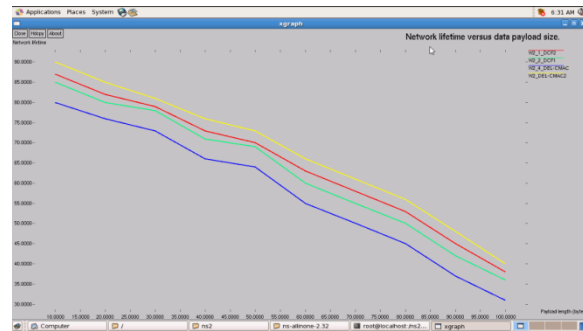

Figure 7: Network lifetime vs. data payload

As the payload of the data packet increases, the network lifetime is decreased (Fig 7).

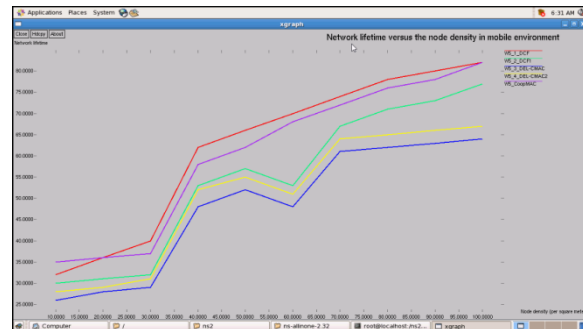

Figure 8: Network lifetime vs. node density in mobile environment.

As we know, in mobile environment the nodes will always move and form different clusters. Now, as the node density in mobile environment increases, the network lifetime will also increase. (Fig 8)

5. CONCLUSION

While LEACH seems to be a promising protocol, there are some areas for improvement that makes the protocol more attractive and widely applicable. In this paper, an energy efficient clustering algorithm has been proposed for Wireless Sensor Network using fuzzy logic concept. By selecting suitable fuzzy descriptors one Super Cluster Head is elected among the cluster heads who is the representative for delivering the message to a mobile base station. The idea of sink mobility along with the fuzzy logic increases the network life time dramatically. It is expected that it would be more useful

in many practical applications like health care, agricultural field, disaster heat areas, military applications etc. Simulation result shows that the proposed protocol performs better than LEACH protocol in terms of first node dies, half nodes alive, last node dies, better stability and better network lifetime.

6. REFERENCES

[1]. W. R. Heinzelman, A. Chandrakasan, and H. Balakrishnan, Energy-efficient Communication Protocol for Wireless Microsensor Networks., in IEEE Computer Society Proceedings of the Thirty Third Hawaii International Conference on System Sciences (HICSS '00), Washington, DC: IEEE, 2000, pp. 1-10.

[2]. W. R. Heinzelman, A. Chandrakasan and H. Balakrishnan, "An application-specific protocol architecture for wireless microsensor networks," in IEEE Transactions on Wireless Communications, 1(4), pp. 660 – 670, Oct. 2002.

[3]. I. Gupta, D. Riordan and S. Sampalli, "Cluster - head Election using Fuzzy Logic for Wireless Sensor Networks", Communication Networks and Services Research Conference, pp. 255-260, May 2005.

[4]. Jong-Myoung Kim, Seon-Ho Park, Young-Ju Han, TaiMyoung Chung, "CHEF: Cluster Head Election mechanism using Fuzzy logic in Wireless Sensor Networks" ICACT, PP. 654-659, Feb. 2008.

[5]. AbhijeetAlkesh, Ashutosh Kumar Singh, N.Purohit, "A moving base station strategy using fuzzy logic for life time enhancement in wireless sensor network", in proc. of International Conference on Communication Systems and Network Technologies, 2011, pp 198-202.

[6]. HodaTaheri et.al. "An energy-aware distributed clustering protocol in wireless sensor networks using fuzzy logic", Ad hoc Networks 10 (2012), pp. 1469-1481.

[7]. Tripti Sharma, Brijesh Kumar, "F-MCHEL: Fuzzy Based Master Cluster Head Election Leach Protocol in Wireless Sensor Network", International Journal of

Computer Science and Telecommunications, Volume 3, Issue 10, October 2012, pp. 8-13.

[8]. Z.W.Siew, C.F.Liau, A.Kiring, M.S. Arifianto, K.T.K. Teo, "Fuzzy Logic Based Cluster Head Election for Wireless Sensor Network", in Proc. of 3rd CUTSE International Conference, Malaysia, 2011, pp. 301-306.

[9]. VibhaNehra, Raju Pal, Ajay K Sharma, "Fuzzy-based Leader Selection for Topology Controlled PEGASIS Protocol for Lifetime Enhancement in Wireless Sensor Network", International Journal of Computers & Technology, Volume 4, No. 3, March-April, 2013, pp.755-764.

[10]. Ge Ran, Huazhong Zhang, Shulan Gong, "Improving on LEACH Protocol of Wireless Sensor Networks Using Fuzzy Logic", Journal of Information & Computational Science 7, (3) (2010), pp. 767–775.

[11]. Hironori Ando, Leonard Barolli, ArjanDuresi, FatosXhafa, and Akio Koyama, "An Intelligent Fuzzy-based Cluster Head Selection System for WSNs and Its Performance Evaluation for D3N Parameter", 2010 International Conference on Broadband, Wireless Computing, Communication and Applications, 2010, pp. 648-653.

- [12]. ZohreArabi, "HERF: A Hybrid Energy Efficient Routing using a Fuzzy Method in Wireless Sensor Networks", International Conference on Intelligent and Advanced Systems (ICIAS), 2010, pp.1-6.
- [13]. E.H. Mamdani, S. Assilian, "An experiment in linguistic synthesis with a fuzzy logic controller", International Journal of Man-Machine Studies 7 (1) (1975), pp. 1-13.
- [14]. Kemal Akkaya, Mohamed Younis, "A survey on routing protocols for wireless sensor networks", Ad Hoc Networks 3 (2005), pp. 325-349.
- [15]. PadmalayaNayak, D. Anurag, V.V.N.A Bhargavi, " Fuzzy based method Super Cluster Head election for Wireless Sensor Network with Mobile Base Station (FM-SCHM)", in Proc. of 2nd International Conference on Advanced Computing Methodologies", GRIET, Hyderabad, 2013, pp. 422-427.