

RecoverMulti PathRouting Procedure Using Virtual Networks

A.Bharath Kumar & G.V.Marutheswar

¹PG Student, Dept of EEE, S V University College Of Engineering, Tirupati .

² Professor, Dept of EEE, S V University College Of Engineering, Tirupati.

¹bharathkumar107@gmail.com, ²marutheswargv@rediffmail.com

Abstract: *With the recent advent of Internet of Humans (IoH) wireless body-to-body networks (WBBNs) are emerging as the fundamental part of this new paradigm. A routing protocol's responsibility lies in determining the way routers communicate with each other in order to forward any kind of packets from a source to a destination using the optimal path that would provide the most efficiency. Real-time critical multimedia requires efficient routing for data delivery with guaranteed QoSsatisfying the stringent QoS requirements of multimedia transmission usually translates to high energy consumption. We propose a hop-by-hop dynamic distributed routing scheme for the implementation of this network wide optimization problem. Our scheme is more practical to realize in large distributed networks compared with current centralized energy minimization methods. We can also achieve near global optimal in a distributed manner and used shortest path routing protocols such as OSPF cannot make it. The proposed algorithm configures energy aware cluster consisting of one*

header node and multiple member nodes. The Software Defined Networking (SDN) has the potential to enable dynamic configuration and control for the enhanced network management. This paper presents the design of a virtualization controller based on network policy in SDN environments. The propos novel routing algorithms for decreasing the energy consumption of optical networks to sleep cycle protocols for use in the network nodes. Energy-Aware optical network protocols can impact the Quality of Services (QoS) such as bit-error-rate (BER) and delay.

Index Terms: Energy management, QoS, Grid networks, Virtual Routing; Network Virtualization; SDN. Power consumption, wired network, Internet of Humans (IoH); data dissemination; clustered.

1. INTRODUCTION

The internet of things (IoT) is emerging as a key enabling technology for the next generation of inter-connected world. It is based on the concept of unique addressable

objects, which can virtually and seamlessly connect to each other any time and everywhere [1]. A network simulation is a technique for modeling the behavior of a network by calculating the interaction between the different network entities using mathematical formulas capturing and playing back observations from a production network [2]. In this article the routing protocols that can balance out the trade-off between network lifetime and QoS requirements are called “green routing protocols [3]. There are works focusing on energy saving at the network-wide level such as designing energy saving network routing protocols based on energy-aware network devices [4]. First proposed the importance of considering energy saving from a network protocols view [5]. We propose a packet delivery mechanism in order to minimize power consumption during off-peak period in wired network. Assuming the functions of layers in network node is controlled independently the proposed mechanism first selects header nodes (HNs) for general IP routing and configure clusters with the center of HNs [6]. To overcome this limitation, the present paper presents the design and implementation of a virtualization controller

which configures virtual networks in flexible way for the deployment of various services while hiding the complexity of networks in SDN environments [7]. We propose a clustered node architecture similar to the one proposed the clustering approach was proposed to reduce packet loss here we utilize a similar approach with a different objective energy minimization. The selection of these clusters can be static or dynamic [8].

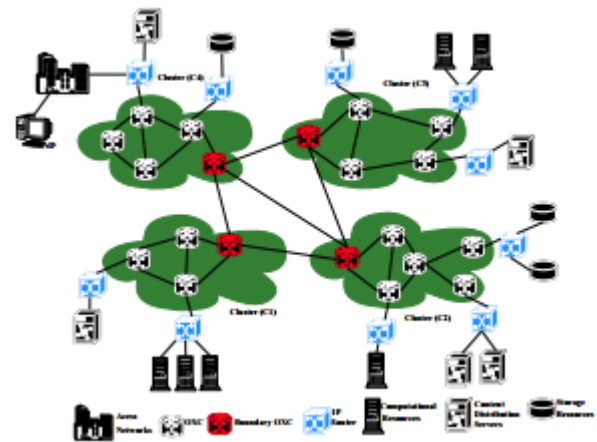

Fig. 1. Network Cluster Architecture

2. RELATED WORKS

Wireless Sensor Networks (WSNs) is composed by a certain number of sensor devices distributed on an area of interest. Sensor devices are severely constrained in terms of memory, computation capabilities, wireless range and battery power [9].

Sensors sense the environment physical measurements and send them towards a sink. The sensing process could be either triggered by the source-node depending on the events requested by the sink [10]. RIP is a distance-vector routing protocol that is based on the Bellman-Ford algorithm and uses hops as a routing metric. It avoids loops by limiting the number of hops that are allowed in a single path, from a source to a destination [11]. Recently triggered by the exponential growth of network traffic volume the spreading of internet access, and the expanding new ICT services being offered by service and network providers, the energy efficiency has become a high-priority object also in the area of wired networks [12]. Most SDN controllers offered a low-level programming interface based on the Open Flow. Increasingly recent SDN controllers have focused on supporting advanced features such as isolation [13]. We briefly discuss solutions and technology related to the proposed SDN virtualization. Optical networks are evolving into a complex interconnection of circuit-switched networks due to the continued growth in high-bandwidth applications [14]. The E-Science community is a fine example of such applications which has already

started using optical networks as the backbone network to support multiter bit connectivity [15].

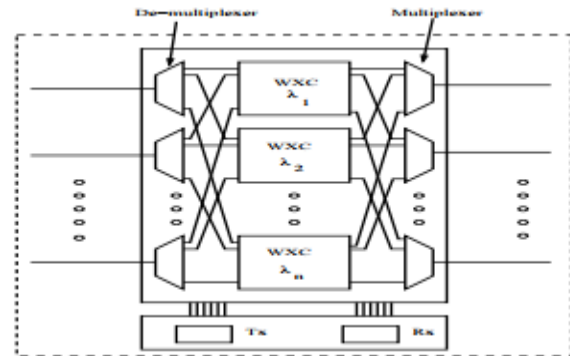

Fig. 2. Optical Cross-connect (OXC) Network Architecture.

3. MULTIPATH ROUTING SYSTEM

Proposed a Two-Phase Geographic Greedy Forwarding (TPGF) algorithm for WMSNs. Phase 1 of TPGF is responsible for exploring a delivery guaranteed routing path while bypassing routing holes. Phase 2 is for optimizing the selected routing path with the least number of hops. The first phase consists of two steps: greedy forwarding and step back and mark [16]. During the greedy forwarding phase a forwarding node selects its next-hop node that is closest to the base station among all its one-hop neighbor nodes [17]. In multi-path routing algorithm Ant

Colony Based Multi-Path Routing Algorithm (ACMRA) is proposed to find the routing path set. The path bandwidth, path delay, and packet loss rate are taken into account for QoS parameters [18].

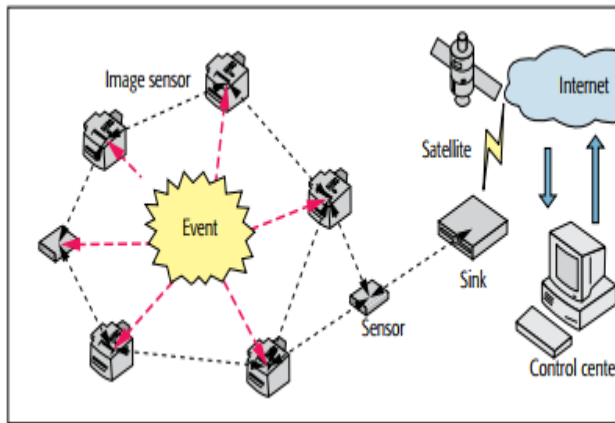

Figure 3. Model of a WMSN in REAR protocol

4. AUTOMATIC CONFIGURATION AND OPERATION OF VIRTUAL NETWORKS

We describe the abstraction mechanism in a virtualization controller presenting the topology of virtual networks formed by its sets of the partitioned or combined network resources with the separate view of network [19]. The proposed virtualization controller offers the function of virtual routing to control policy-based connectivity among logical network segments, tenant networks

and external network by installing packet-handling rules according to specified network policy on the distributed [20]. Once the created virtual routers and interfaces are connected after the configuration of logical network segments the virtualization controller can configure routing virtual routers by specifying policy to describe routing rules the tenant routers and the system router can control connectivity of logical groups by specifying routing rules over distributed virtual routers [21].

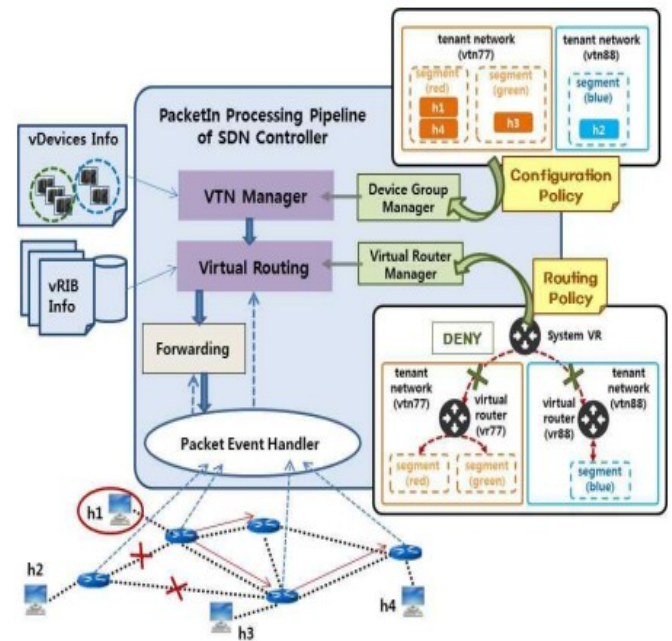

Figure 4. The policy-based flow processing for virtual routing

A. Bellman-Ford Algorithm:

The Bellman Ford algorithm is an algorithm that computes shortest paths from a single source vertex to all of the other vertices in a weighted graph. It is similar to Dijkstra but instead of greedily selecting the minimum weighted node, not yet processed, to relax, it simply relaxes all edges, and does this $|V|-1$ times. The repetitions allow minimum distances to propagate accurately, since in the absence of negative cycles, the shortest path can visit each node at most once [22]. Bellman Ford can detect cycles and report their existence, and its running time is $O(|V|*|E|)$ where v denotes the number of vertices in the directed graph, and e the number of edges [23].

```
BELLMAN-FORD( $G, w, s$ )
1 INITIALIZE-SINGLE-SOURCE( $G, s$ )
2 for  $i \leftarrow 1$  to  $|V[G]| - 1$ 
3   do for each edge  $(u, v) \in E[G]$ 
4     do RELAX( $u, v, w$ )
5 for each edge  $(u, v) \in E[G]$ 
6   do if  $d[v] > d[u] + w(u, v)$ 
7     then return FALSE
8 return TRUE
```

Figure 5: Bellman-Ford algorithm pseudo code

B. Distributed Routing Algorithm

The distributed routing algorithm is developed based on the necessary and

sufficient conditions for optimal routing. Each node i in the network maintains a routing RT_i . Each entry r_{ij} of the routing RT_i records routing information for destination j including next hops to j , marginal distance from i to j and routing variables for next hops. Routing variables reflect the traffic allocation strategy among next hops. Calculating the routing variables is the key of our distributed routing algorithm [24]. The time complexity for updating information of one destination in one iteration is $O(D)$, in which D is the diameter of the network topology. Based on numerical results, our algorithm can converge to the near global optimal within 15 rounds iteration.

Algorithm: Routing under dynamic traffic flow

1: each destination j maintains a timer I to record the time passing in an epoch. I is initialized as T .

2: each node i initializes $r_{ij}(0)$.

3: When the new epoch begin, every destination j sends up in the GEN /G (j) a "signal" for all nodes to start a new epoch and reset I as T .

4: When node i receives the "signal" in the epoch L , it drops $r_{ij}(L)$ and uses the $r_{ij}(L+1)$ for the new epoch $L+1$. Then, it starts to update routing variable set using current traffic flow information in the new epoch.

5: each node i is continuously monitoring the traffic flow (the arrival rate r_{ij}) and after every fixed interval it recomputed a new r_{ij} for destination j .

When the traffic flow is dynamic, according to the variation of the traffic is divide the time into epochs with fixed length of T time units. During an epoch, the routing variable set Φ_{ij} for all j is updated. Under dynamic traffic in the epoch each node allocates traffic demand passing through it according to the current routing variable set [25].

5. PACKET DELIVERY ALGORITHM

Power consumption in network nodes is generally assumed to be independent from current load, so a fixed amount of power is consumed when the network node is on. It is representative of current network equipments, as reported by real measurements [26]. Based on energy consumption model of network node the sum of the consumption of all nodes and

corresponding links is generally used to express total network power consumption. Packet delivery algorithm that is the objective of our research is presented with several procedures in detail. First, we define header node(HN) and member node(MN). HN mean general IP router for IP packet processing and MN mean special node is forward IP packet using defined tag when its function of layer 3 is in sleep mode. Tag is an identifier binding to outgoing interface in node and assigned at HNs architecture of HNs and MNs and the logic for energy-efficient packet delivery [27].

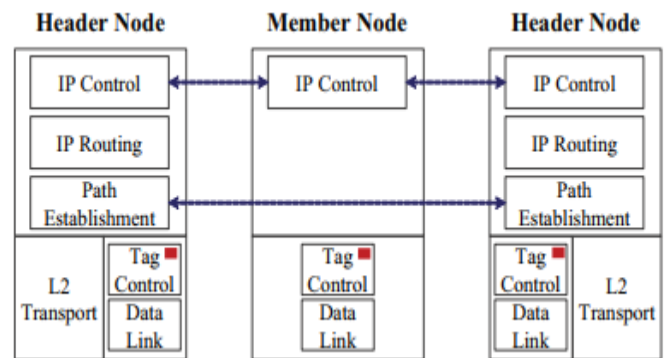

Fig. 6. The logic for energy-efficient packet delivery

Algorithm Pseudo code for header node selection

U_i : network utilization of node i

$U_{i,j}$: network utilization of link from i to j

Node_j : adjacent of node i

1. for node $i = 1$ to $i = N$ do
2. SendToNeighbor(node _{$i \rightarrow j$} , u_i , $u_{i,j}$)
3. ReceiveFromNeighbor(node _{$j \rightarrow i$} , u_j , $u_{j,i}$)
4. InsertNeighbor Node(node _{j} , $u_i + u_{i,j} - u_j - u_{j,i}$)
5. end for
6. Cal Until Gap(i) = $\sum_k u_i (u_i + u_{i,j} - u_j - u_{j,i})$ k is the number of adjacent node i .
7. if Cal Until Gap(i) $\geq u_{TH}$ u_{TH} is pre-defined threshold value by network provider. then
8. node i is selected to be a Header Node(HN)
9. else
10. node i is selected to be a Member Node(MN)
11. end if

For operation between node from source and node f to destination node a receives packets without tags and forwards them to node d . As an assumption to operate, MN forwards packets to HN if there is no tag information in routing entry of MN.

6. PERFORMANCE ANALYSIS

In order to investigate the performance of the proposed algorithm, we run several simulations using the NS-2 simulator under the well-known NSFNet topology with 14 nodes and 42 links. Our simulation mainly has two goals: To compare the performance of the distributed routing algorithm on GEN G(t) we generated with the optimal solution and with the distributed routing algorithm on optimal. It is clear that both clustered and distributed-based approaches have similar behavior with DQPSK with different variation of the payload and frequencies. Best average delay is given by the distributed-based approach with 64 bytes payload at both utilized frequencies. Accordingly to the PRR, worst performance is noticed for distributed-based dissemination strategy for all payload values and frequencies.

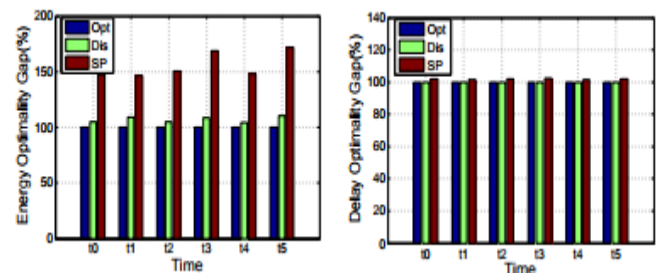

Figure 7: Comparison among methods on total delay and energy

7. CONCLUSIONS AND FUTURE WORK

Currently there are very few studies which have evaluated the performance of such emerging networks especially in the context of emergency management and rescue operations. Energy efficiency is becoming a key factor in green ICT industry. As a research for green network, we provide an algorithm to minimize power consumption in wired network in this paper. It configures clusters consisting of one HN and multiple MNs according to selection method, forwards packets using tags. We have proposed the design of a virtualization controller based on network policy. To deploy various services and achieve a better QoS, the proposed controller configures multiple virtual networks, which are customized with special goals on the same physical infrastructure. This energy saving is obtained without sacrificing the QoS. We will consider dynamic sleep-cycles for the clusters based on the traffic conditions in our future work. In our future works, we will work on the improvement of the loop-free multi-path finding algorithm and try to give theoretical measurements of the optimality

of DAGs. Meanwhile to speed up the convergence is also an interesting topic.

8. REFERENCES

- [1] J. Carter and K. Rajamani, "Designing energy-efficient servers and data centers," *Computer*, vol. 43, no. 7, pp. 76–78, Jul. 2010.
- [2] L. Yao, W. Wen, and F. Gao, "A Real-Time and Energy Aware QoS Routing Protocol for Multimedia Wireless Sensor Networks," *Proc. 7th World Congress on Intelligent Control and Automation*, 2008, pp. 3321–26.
- [3] L. Shu et al., "TPGF: Geographic Routing in Wireless Multimedia Sensor Networks," *Telecommun. Systems*, vol. 44, no. 1–2, 2010, pp. 79–95.
- [4] M. Andrews, A. F. Anta, L. Zhang, and W. Zhao. Routing for energy minimization in the speed scaling model. *IEEE/ACM Transaction on Networking*, 20(1):285–294, 2012.
- [5] S. Antonakopoulos, S. Fortune, and L. Zhang. Power-aware routing with rate-

adaptive network elements. In GLOBECOM Workshops, pages 1428–1432, 2010.

[6] A. Plepys, “The grey side of ICT,” *Journal of Environmental Impact Assessment Review*, vol. 22, no. 5, pp. 509–523, 2002.

[7] A. Jukan and G. Karmous-Edwards, “Optical control plane for the grid community,” *IEEE Communications Surveys and Tutorials*, vol. 9, no. 3, pp. 30–34, 2007.

[8] A. Jukan and G. Franzl, “Path selection methods with multiple constraints in service-guaranteed WDM networks,” *IEEE/ACM Transactions on Networking*, vol. 12, no. 1, pp. 59–72, 2004.

[9] A. and Bloom, *Trends: The Internet of Humans (not Things)—Sensors, Health, Fitness, & Healthcare*, Pivotal, 2015.

[10] E. Ben Hamida, M. M. Alam, M. Maman, B. Denis and R. D’Errico, “Wearable Body-to-Body Networks for Critical and Rescue Operations Workshop on The Convergence of Wireless Technologies for Personalized Healthcare, Washington DC, 2014.

[11] L. Chiaraviglio, M. Mellia, and F. Neri, “Reducing power consumption in backbone networks,” in *IEEE ICC*, Jun. 2009.

[12] Y.-M. Kim, E.-J. Lee, and H.-S. Park, “Ant colony optimization based energy saving routing for energy-efficient networks,” *IEEE Communications Letters*, vol. 15, Jul. 2011.

[13] A. Valdivieso, L. Barona, and L. Villalba, “Evolution and challenges of software defined networking,” in *Proceedings of the 2013 Workshop on Software Defined Networks for Future Networks and Services*, IEEE, November 2013, pp. 61–67.

[14] N. Fernandes et al., “Virtual networks: isolation, performance, and trends,” *Annals of Telecommunications*, vol. 66, Oct. 2011, pp. 339–355.

[15] P. Szegedi, S. Figuerola, M. Campanella, V. Maglaris, and C. Cervello-Pastor, “With evolution for revolution: Managing federica for future internet research,” *IEEE Communications*, vol. 47, no. 7, 2009, pp. 34–39.

[16] X. Cao et al., “Multi-Path Routing Algorithm for Video Stream in Wireless

Multimedia Sensor Networks,” *J. Software*, vol. 23, no. 1, 2012, pp. 108–21.

[17] F. Li et al., “QoS Differentiated Service Routing for Wireless Multimedia Sensor Networks,” *Acta Electronica Sinica*, vol. 38, no. 10, 2010, pp. 2322–28.

[18] A. Sheikh, E. Felemban, and S. Basalamah, “Priority-Based Routing Framework for Multimedia Delivery in Surveillance Networks,” *6th Int’l. Conf. Advances in Multimedia*, 2014, pp. 1–9.

[19] N. McKeown et al., “OpenFlow: enabling innovation in campus networks,” *ACM SIGCOMM Computer Communication Review*, vol. 38, April 2008, pp. 69–74.

[20] J. Carapinha and J. Jim’enez, “Network virtualization: a view from the bottom,” in *Proceedings of the 1st ACM workshop on Virtualized infrastructure systems and architectures*. ACM, 2009, pp. 73–80.

[21] C. Monsanto, J. Reich, N. Foster, J. Rexford, and D. Walker, “Composing Software Defined Networks,” In *Proc. NSDI*, Apr. 2013, pp. 1-14.

[22] C. X. Mavromoustakis, A. Bourdena, G. Mastorakis, E. Pallis, G. Kormentzas, and C. D. Dimitriou, “An Energy-Aware Scheme for Efficient Spectrum Utilization in a 5G Mobile Cognitive Radio Network Architecture”, accepted for publication in the Special Issue on Energy Efficient 5G Wireless Technologies, *Springer Telecommunication Systems Journal*, 2015.

[23] A. Andreou, C. X. Mavromoustakis, G. Mastorakis, A. Bourdena, E. Pallis, “Adaptive Heuristic-Based P2P Network Connectivity and Configuration for Resource Availability” in the book *Resource Management in Mobile Computing Environments*, pp. 221-240, 2014, Springer International Publishing.

[24] A. Bourdena, C. X. Mavromoustakis, G. Kormantzas, E. Pallis, George Mastorakis, MuneerBaniYassein, “A Resource Intensive Traffic-Aware Scheme using Energyefficient Routing in Cognitive Radio Networks”, *Future Generation Computer Systems Journal*, Elsevier; Volume 39, October 2014, pp. 16-28.

[25] L. Chiaraviglio, D. Ciullo, M. Meo, M. A. Marsan, and I. Torino, “Energy-aware

umts access networks,” in IEEE W-GREEN, 2008.

[26] X. Wang, M. Veeraraghavan, T. Miyazaki, S. Okamoto, N. Yamanaka, and I. Popescu, “Dynamic layer-1 wan access architecture for large enterprises,” in IEEE ICNC, 2015.

[27] M. Jimeno and B. Christensen, K.andNordman, “A network connection proxy to enable hosts to sleep and save energy,” in IEEE IPCCC, Dec. 2008.

Author details:



G.T.Harikrishna Murthy born in Nandyal, Kurnool (DT) of Andhra Pradesh, India. He received M.C.A, from Nagarjuna University, Guntur, Andhra Pradesh, India. I Completed M.tech in C.S.E from Dr. Samuel George Institute of Engineering & Technology, Markapur, Prakasam (DT), Andhra Pradesh, India. Affiliated to JNTU Kakinada, East Godavari (DT), Andhra Pradesh, India. I Attended Few Workshops.