

An Enhancement in Finding Power Quality Conditioner for Power Quality of Micro-Grid

S Srinivasu & D Mohan Reddy

¹PG Scholar, Dept of EEE, Amalapuram Institute Of Management Sciences & College Of Engineering

²Professor & Principal, Amalapuram Institute of Management Sciences and College of Engineering, Mummdivaram, East Godavari District, Andhra Pradesh, India

Abstract. *This paper focus on specially designed Fuzzy based Power Quality Conditioner for Micro Grid applications. Three leg inverter coupled with solar PV with MPPT used as Compensator can be used for distinct DGs in the micro grid for power quality improvement of the entire system. Optimum control can be achieved to avoid detraction for voltage, current and Power flowing between Grid and DG. The Power Quality conditioner and DG inverter have dual use for this particular purpose. Primarily used as power converter for injecting power created from DG to Grid, secondly performed as parallel Active Power Filter for compensating harmonics, unbalanced voltage, current, active and reactive power demand for the balance and unbalance burden with in the Grid and neutral conductors. This paper is extended with Fuzzy Logic Controller for better improvement of Power Quality. The above mentioned task extensively simulated under MATLAB/Simulink platform reveals that soon after compensation the THD.*

KEYWORDS: FUZZY LOGIC, MPPT, PV.

INTRODUCTION

Basically, the microgrid system is a combination of loads and different micro sources operating as a single system providing power. The structure of a microgrid system consists of different parts such as interface control, control and protection devices for each micro sources as well as microgrid voltage control, power flow controlling devices, load sharing during islanding conditions, protection and stability [1]. The ability of the Microgrid to operate when connected to the grid, smooth

transition to and from the island mode is another important function.

The main consideration for interconnection of microgrid to the distribution system is the impact of power quality problems on the overall power systems. Generally, these power quality problems are classified as voltage and frequency deviations in grid voltage and harmonic contents in load current. In order to overcome these type of power quality problems this paper proposes a concept of flexible ac distribution system for microgrid. This flexible ac distribution system is a combination of series and shunt converters shared by a common dc link capacitor [2]. The proposed dc link source of the FACTS device is obtained by a distributed energy source. This paper also proposes the concept of fuzzy controller for obtaining better harmonic distortions.

DISCRIPTION OF PROPOSED SYSTEM:

In an electrical power system the microgrid is commonly a group of electrical loads and power generations from different generating sources like solar wind etc. these microgrid plays an important role to enhance the reliability, increasing efficiency and voltage sag correction. The complete structure of the proposed FACTS device and microgrid structure is shown in Figure 1 [3].

From this figure 1, the structure of microgrid consists of three feeder terminals. And the flexible ac transmission system is used for power quality compensation. And the device is also used for compensating harmonic content in both grid voltage and load currents [4].

The operation and constructional structure of flexible ac distribution system is explained in the next section.

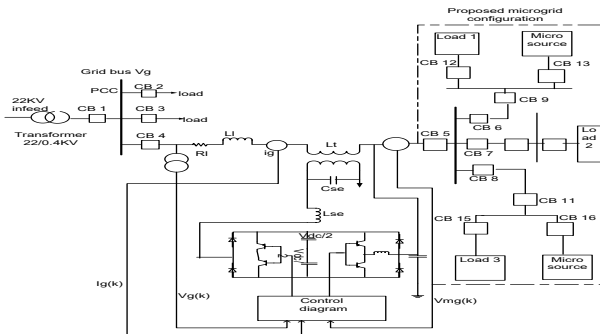

Fig.1. Configuration of Proposed FACTS device based Microgrid system

Unified Power Quality Controller

One of the compensating devices from the FACTS family, called Unified Power Quality Conditioner, is the efficient method to improve power quality [5]. The Unified power quality controller is a combination of series and shunt controller separated by a common dc-link for exchanging reactive power.

A shunt device is one of the compensated equipment which is connected at the transmission system. This shunt compensated system has the capability of either absorbing or generating active power at the point of connection thereby controlling the voltage magnitude. To compensate for the inductive voltage drop, a capacitor can be inserted in the line to reduce the line impedance.

The series compensated device is connected in series with the line for controlling the transmission parameters such as transmission impedance [6] by controlling reactance, fluctuations in system voltage. The structure of the unified power quality conditioner is shown in figure 2.

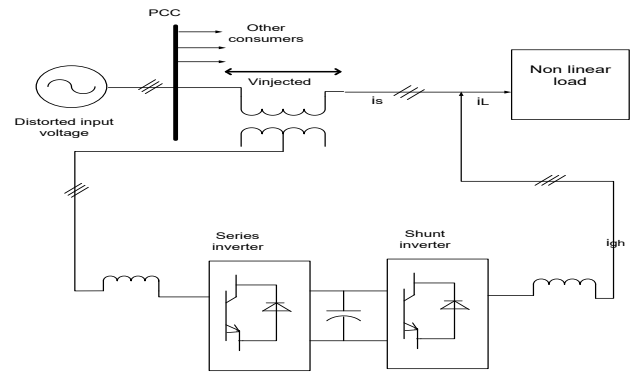

Fig.2.structure of unified power quality conditioner

The series controller which is explained in this section is used for compensating the grid voltage. It is controlled with help of three phase converter. The control diagrams for the both series and shunt converters are shown in figure 3 and figure 4.

Figure 3 shows the closed loop control diagram for the series converter. The active/reactive powers, grid voltages and currents are used as reference signals to control the series converter. In this the grid voltage and load voltages are compared and generate the reference voltage signals [7]. These reference signals are compared with carrier signal in pulse width modulation technique which generates the gate signals to series voltage source converter.

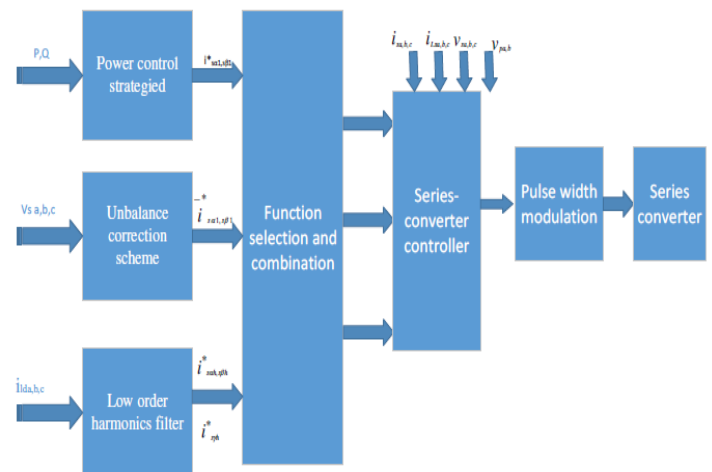

Fig.3.Control Diagram of series converter

The control structure of the shunt converter is shown in figure 4. The park's transformation technique is used for converting

three phase current coordinates to two phase currents commands for calculating the error signals. These reference signals are compared with carrier signal in pulse width modulation technique which generates the gate signals to shunt voltage source converter [8].

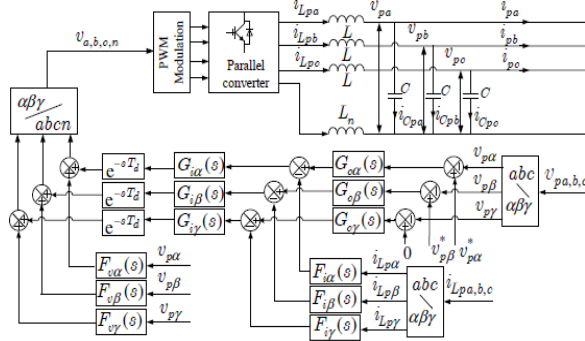

Fig.4. Control Diagram of shunt converter

Basically, the unified power quality conditioner has a capability to compensate harmonics in load current, reactive power, voltage variations and controlling the power flow [9]. But the unified power quality conditioner has no capability in compensating the voltage fluctuations in a system because there is no energy storage. Now, this paper presents a concept of UPQC that is incorporated with distribution, generation system as a dc-link through the rectifier [10].

Therefore, the unified power quality conditioner compensates these voltage fluctuations in the grid, while the distribution generation system supplies power to grid and load. These proposed DG system is operated in two modes. One is DG provides power to load and source called as interconnected mode and second one is DG provides power to load only called as islanding mode. In this paper the photovoltaic generating plant [11] is considered as a one of the distribution generation system. The structure of unified power quality conditioner based distributed generating system is as shown in figure 5.

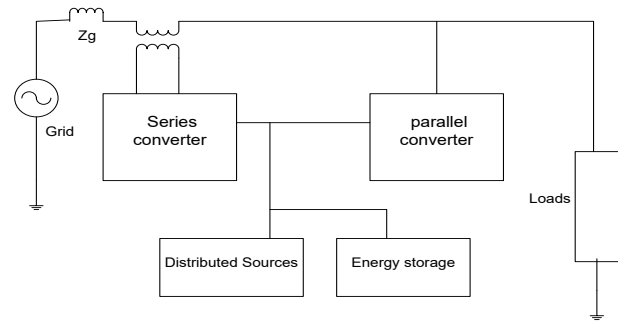

Fig.5. Configuration of UPQC system with DG

FUZZY INFERENCE SYSTEM:

The fuzzy logic controller is one of the advanced soft computing controller which is used for controlling the system output. As compared with the other conventional controllers, fuzzy logic controller has the advantage of fast computing, better response, low settling time and high running response. The fuzzy logic controller operation can be explained in mainly four ways i.e 1. Fuzzification, 2.Membership function, 3.Rule-base formation and 4.Defuzzification.

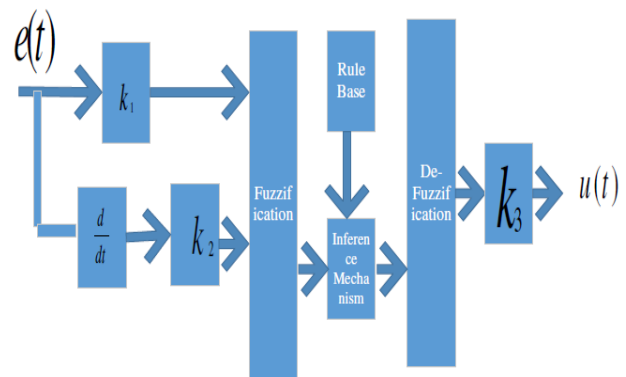

Fig.6. Block diagram of Fuzzy Logic Controller

The basic block diagram for the fuzzy logic controller as shown in Figure6. The rule base taken for this system is shown below in table 3.1. The input variables such as error and error rate are expressed in terms of fuzzy set with the linguistic terms VN, N, Z, P, and VP [12]. In this type of mamdani fuzzy inference system the linguistic terms are expressed using

triangular membership functions. $L(e, ce) = \{VN, N, Z, P, VP\}$

The inputs for the fuzzy system are represented as error and error rate and its rule base formations are shown in above table. The fuzzy rules are obtained with the statement of if-then statements. The given fuzzy inference system is a combination of two inputs and one output. These two inputs are related with the logical AND/OR operators. AND logic gives the output as minimum value of the two inputs and OR logic produces the output has maximum value of two inputs. I.e if the input1 is zero and input2 is zero then the output is zero. The input and output membership function are shown in figure 7 and figure 8.

The membership function for the input error is as shown below.

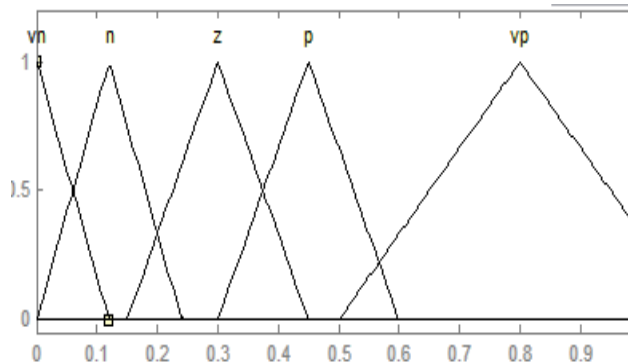

Fig.7. membership function representation for input 1

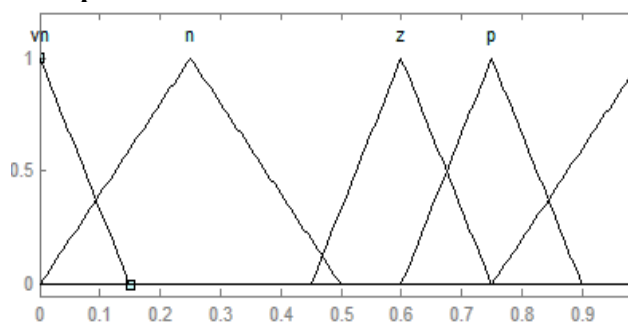

Fig.8. membership function representation for input 2

The type of membership functions used here are Triangular type and the membership function range is -1 to 1 i.e., universe of discourse. And the relation between input and output variables obtained with the help of if-then

rule base formation. The de-Fuzzification is done by using Centroid method.

EXPERIMENTAL VERIFICATION:

The experimental verification for the proposed Fuzzy based UPQC micro-grid system is verified in Matlab/Simulink in two cases. The simulation diagram for this proposed system is as shown in figure 9.

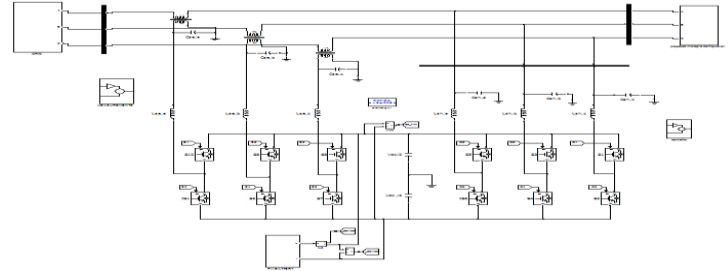

Fig.9. Simulink structure of proposed Micro-Grid System with UPQC controller

Case 1: with PI Controller

In this case the proposed grid interfaced system is implemented with PI controller and the results are shown below.

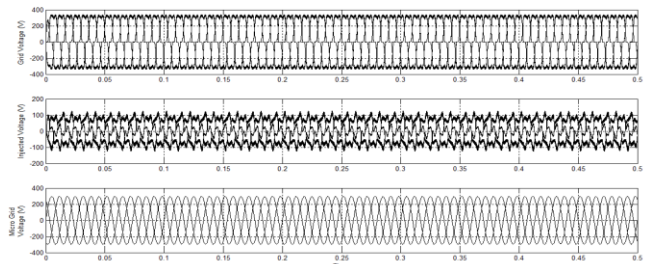

Fig.10. Simulation result for Feeder currents

Figure 10 shows the simulation results for the system feeder currents under without and with compensation.

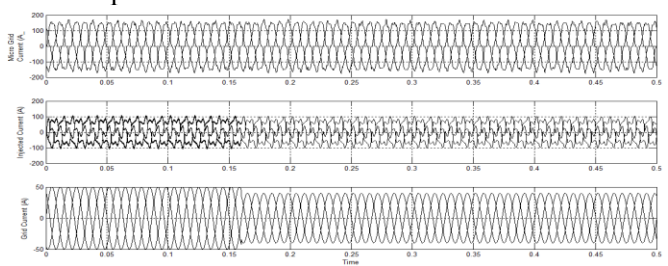

Fig.11. Simulation result for Grid, Series Converter and Micro-Grid Voltage

Figure 11 shows the simulation results for the system micro grid voltage under without and with compensation.

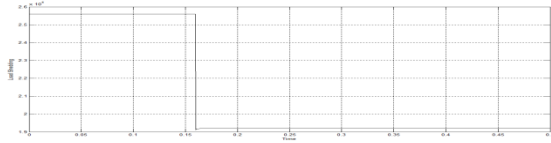

Fig.12. Simulation result for Active Power under Islanded condition

Figure 12 shows the simulation result for the active and reactive powers under Islanded condition. In this case we consider the islanded condition at time $t=0.17$ sec and at that the grid is disconnected from the system.

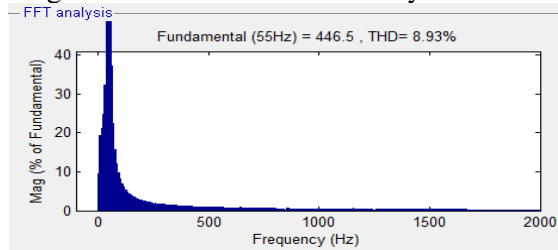

Fig.13. FFT Analysis
Case 2: with fuzzy controller:

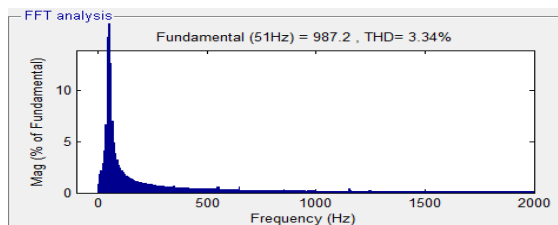

Fig.14. FFT Analysis

Figure 13 and Figure 14 shows the total harmonic distortion values with PI and Fuzzy controllers. From these figure it conclude that the fuzzy control provide better harmonic distortion factor of load current as compared with conventional PI controller.

CONCLUSION

This paper has successfully implemented the microgrid based unified power quality conditioner along with the fuzzy logic controller. Generally, the microgrid concept mainly concentrates on the reduction of power quality problems associated with the system, the later are compensated by unified power quality

controller. The fuzzy logic controller is used for getting better performance by the reduction of total harmonic distortion in the system.

The simulation results are obtained for the Grid interfacing using series and parallel converter system with conventional PI controller and Fuzzy logic controller. Due to the presence of non-linearity in the system, harmonics are produced which lead to voltage distortions. By using conventional PI controller in the system we can reduce these distortions. However, it is found, through the simulation results, that fuzzy logic controller can do better in reducing harmonics & improves THD.

REFERENCES

- [1] F.Wang, J.L.Duarte, and M.A.M. Hendrix, "Grid-Interfacing Converter Systems with Enhanced Voltage Quality for Microgrid Application Concept and Implementation" IEEE 2011. Volume: 26, Issue: 12
- [2] F.Wang, J.L.Duarte, and M.A.M.Hendrix, "Pliant active and reactive power control for grid-interactive converters under unbalanced voltage dips," IEEE Transactions on Power Electronics, in press, 2010. Volume: 26, Issue: 5.
- [3] H.Farhangi, "The path of the smart grid," IEEE Power Energy Mag., vol. 8, no. 1, pp. 18-28, Jan./Feb. 2010
- [4] H.Fujita, and H.Akagi, "The unified power quality conditioner: the integration of series- and shunt-active filters," IEEE Trans. Power Electron., vol. 13, no. 2, pp. 315-322, Mar. 1998
- [5] S.Silva, P.F.Donoso-Garcia, P.C.Cortizo, and P.F.Seixas, "A three phase line-interactive ups system implementation with series-parallel active power-line conditioning capabilities," IEEE Trans. Ind. Appl., vol. 38, no. 6, pp. 1581-1590, Nov./Dec. 2002.
- [6] B.Han, B.Bae, H.Kim, and S.Baek, "Combined operation of unified power-quality conditioner with distributed generation," IEEE Trans. Power Delivery, vol. 21, no. 1, pp. 330-338, Jan. 2006.
- [7] H.Tao, "Integration of sustainable energy sources through power electronic converters in small distributed electricity generation systems," PhD dissertation, Eindhoven university of technology, 2008.

- [8] J.M.Guerrero, L.G.D.Vicuna, J.Matas, M.Castilla, and J.Miret, "A wireless controller to enhance dynamic performance of parallel inverters in distributed generation systems," IEEE Trans. Power Electron., vol. 19, no. 5, pp. 1205-1213, Sept. 2004.
- [9] Y.W.Li, and C.N.Kao, "An accurate power control strategies for power-electronic-interfaced distributed generation units operating in a low-voltage multi bus micro grid," IEEE Trans. Power Electron., vol. 24, no. 12, pp. 2977-2988, Dec. 2009.
- [10] F.Wang, J.LDuarte, and M.A.M.Hendrix, "Reconfiguring grid interfacing converters for power quality improvement," in Proc. IEEE Benelux Young Researchers Symposium \ in Electrical Power Engineering, 2008, pp. 1-6.
- [11] SungwooBae, Alexis Kwasinski "Dynamic Modeling and Operation Strategy for a Microgrid with Wind and Photovoltaic Resources" IEEE 2012 TRANSACTIONS ON SMART GRID Volume: 3, Issue: 4
- [12] L.H.Tey, Member, IEEE, P.L.So, Senior Member, IEEE, and Y.C.Chu, Member, IEEE "Improvement of Power Quality Using Adaptive Shunt Active Filter using Fuzzy Logic Controller "IEEE TRANSACTIONS ON POWER DELIVERY, VOL. 20, NO. 2, APRIL2005.