

Low hardware Accumulator Based 3-Weight Pattern Generation for Boundary Scan

Manthri Lavanya & K.Saifuddin

¹ M.Tech ,Assistant Professor, Department of ECE, Anantha Lakshmi Institute of Technology, Anantapur, Ap, India.

² M.Tech ,Assistant Professor, Department of ECE , Srinivasa Ramanujan Institute of Technology, Anantapur, Ap, India.

ABSTRACT:

Weighted pseudorandom built-in self test (BIST) schemes have been utilized in order to drive down the number of vectors to achieve complete fault coverage in BIST applications. Weighted sets comprising three weights, namely 0, 1, and 0.5 have been successfully utilized so far for test pattern generation, since they result in both low testing time and low consumed power. In this paper an accumulator-based 3-weight test pattern generation scheme is presented; the proposed scheme generates set of patterns with weights 0, 0.5, and 1. Since accumulators are commonly found in current VLSI chips, this scheme can be efficiently utilized to drive down the hardware of BIST pattern generation, as well. Comparisons with previously presented schemes indicate that the proposed scheme compares favorably with respect to the required hardware.

Keywords: Memory BIST, Address Generation, ALU-based implementation.

I. INTRODUCTION

Pseudorandom built-in self test (BIST) generators have been widely utilized to test integrated circuits and systems. The arsenal of pseudorandom generators includes, among others, linear feedback shift registers (LFSRs) [1], cellular automata [2], and accumulators driven by a constant value [3]. For circuits with hard-to-detect faults, a large number of random patterns have to be generated before high fault coverage is achieved. Therefore, weighted pseudorandom techniques have been proposed where inputs are biased by changing the probability of a “0” or a “1” on a given input from 0.5 (for pure pseudorandom tests) to some other value [10], [12].

Weighted random pattern generation methods relying on a single weight assignment usually fail to achieve complete fault coverage using a reasonable number of test patterns since, although the weights are computed to be suitable for most faults, some faults may require long test sequences to be detected with these weight the assignments if they do not match their activation and propagation requirements. Multiple weight assignments have been suggested for the case that

different faults require different biases of the input combinations applied to the circuit, to ensure that a relatively small number of patterns can detect all faults [4]. Approaches to derive weight assignments for given deterministic tests are attractive since they have the potential to allow complete coverage with a significantly smaller number of test patterns [10]. In order to minimize the hardware implementation cost, other schemes based on multiple weight assignments utilized weights 0, 1, and 0.5. This approach boils down to keeping some outputs of the generator steady (to either 0 or 1) and letting the remaining outputs change values (pseudo-) randomly (weight 0.5). This approach, apart from reducing the hardware overhead has beneficial effect on the consumed power, since some of the circuit under test (CUT) inputs (those having weight 0 or 1) remain steady during the specific test session [30]. Pomeranz and Reddy [5] proposed a 3-weight pattern generation scheme relying on weights 0, 1, and 0.5. The choice of weights 0, 1, and 0.5 was done in order to minimize the hardware implementation cost. Wang [2], [8] proposed a 3-weight random pattern generator based on scan chains utilizing weights 0, 1, and 0.5, in a way similar to [5]. Recently, Zhang *et al.* [9] renovated the interest in the 3-weight pattern generation schemes, proposing an efficient compaction scheme for the 3-weight patterns 0, 1, and 0.5. From the above we can conclude that 3-weight pattern generation based on weights 0, 1, and 0.5 has practical interest since it combines low implementation cost with low test time.

Current VLSI circuits, e.g., data path architectures, or digital signal processing chips commonly contain arithmetic modules [accumulators or arithmetic logic units (ALUs)]. This has fired the idea of arithmetic BIST (ABIST) [6]. The basic idea of ABIST is to utilize accumulators for built-in testing (compression of the CUT responses, or generation of test patterns) and has been shown to result in low hardware overhead and low impact on the circuit normal operating speed [2]–[5]. In [6], Manich *et al.* presented an accumulator-based test pattern generation scheme that compares favorably to previously proposed schemes. In [7], it was proved that the test vectors generated by an accumulator whose inputs are driven by a constant pattern can have acceptable pseudorandom characteristics, if the input pattern is

properly selected. However, modules containing hard-to-detect faults still require extra test hardware either by inserting test points into the mission logic or by storing additional deterministic test patterns [4], [12].

In order to overcome this problem, an accumulator-based weighted pattern generation scheme was proposed in [11]. The scheme generates test patterns having one of three weights, namely 0, 1, and 0.5 therefore it can be utilized to drastically reduce the test application time in accumulator-based test pattern generation. However, the scheme proposed in [11] possesses three major drawbacks: 1) it can be utilized only in the case that the adder of the accumulator is a ripple carry adder; 2) it requires redesigning the accumulator; this modification, apart from being costly, requires redesign of the core of the data path, a practice that is generally discouraged in current BIST schemes; and 3) it increases delay, since it affects the normal operating speed of the adder.

In this paper, a novel scheme for accumulator-based 3-weight generation is presented. The proposed scheme copes with the inherent drawbacks of the scheme proposed in [11]. More precisely: 1) it does not impose any requirements about the design of the adder (i.e., it can be implemented using any adder design); 2) it does not require any modification of the adder; and hence, 3) does not affect the operating speed of the adder. Furthermore, the proposed scheme compares favorably to the scheme proposed in [11] and [12] in terms of the required hardware overhead. This paper is organized as follows. In Section II, the idea underlying the accumulator-based 3-weight generation is presented. In Section III, the design methodology to generate the 3-weight patterns utilizing an accumulator is presented. In Section IV, the proposed scheme is compared previously proposed ones. Finally, Section V, concludes this paper.

TABLE I
TEST SET FOR THE C17 BENCHMARK

Test vector	Inputs A[4:0]
T1	00101
T2	01010
T3	10010
T4	11111

TABLE II
TRUTH TABLE OF THE FULL ADDER

#	C _{in}	A[i]	B[i]	S[i]	C _{out}	Comment
1	0	0	0	0	0	
2	0	0	1	1	0	C _{out} = C _{in}
3	0	1	0	1	0	C _{out} = C _{in}
4	0	1	1	0	1	
5	1	0	0	1	0	
6	1	0	1	0	1	C _{out} = C _{in}
7	1	1	0	0	1	C _{out} = C _{in}
8	1	1	1	1	1	

II. ACCUMULATOR-BASED 3-WEIGHT PATTERN GENERATION

We shall illustrate the idea of an accumulator-based 3-weight pattern generation by means of an example. Let us consider the test set for the c17 ISCAS benchmark [12], [3] given in Table I. Starting from this deterministic test set, in order to apply the 3-weight pattern generation scheme, one of the schemes proposed in [5], [8], and [9] can be utilized. According to these schemes, a typical weight assignment procedure would involve separating the test set into two subsets, S1 and S2 as follows: S1 = {T1, T4}, S2 = {T2, T3}. The weight assignments for these subsets is W(S1) = {-,-,1,-,1} and W(S2) = {-,-,0,1,0} where a “-” denotes a weight assignment of 0.5, a “1” indicates that the input is constantly driven by the logic “1” value, and “0” indicates that the input is driven by the logic “0” value. In the first assignment, inputs A[2], and A[0] are constantly driven by “1”, while inputs A[4], A[3], A[1] are pseudo randomly generated (i.e., have weights 0.5). Similarly, in the second weight assignment (subset S2), inputs A[2] and A[0] are constantly driven by “0”, input A[1] is driven by “1” and inputs A[4] and A[3] are pseudo randomly generated. The above reasoning calls for a configuration of the accumulator, where the following conditions are met: 1) an accumulator output can be constantly driven by “1” or “0” and 2) an accumulator cell with its output constantly driven to “1” or “0” allows the carry input of the stage to transfer to its carry output unchanged. This latter condition is required in order to effectively generate pseudorandom patterns in the accumulator outputs whose weight assignment is “-”.

III. DESIGN METHODOLOGY

The implementation of the weighted-pattern generation scheme is based on the full adder truth table, presented in Table II. From Table II we can see that in lines #2, #3, #6, and #7 of the truth table Cout = Cin. Therefore, in order to transfer the carry input to the carry output, it is enough to set A[i] = NOT B[i]. The proposed scheme is based on this observation.

The implementation of the proposed weighted pattern generation scheme is based on the accumulator cell

presented in Fig. 1, which consists of a Full Adder (FA) cell and a D-type flip-flop with asynchronous set and reset inputs whose output is also driven to one of the full adder inputs. In Fig. 1, we assume, without loss of generality, that the set and reset are active high signals. In the same figure the respective cell of the driving register B[i] is also shown. For this accumulator cell, one out of three configurations can be utilized, as shown in Fig. 2.

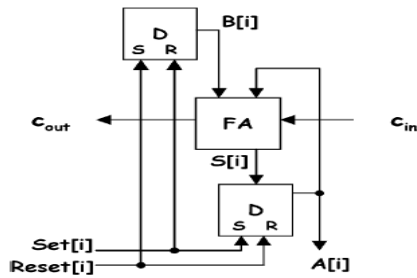

Fig. 1. Accumulator cell.

In Fig. 2(a) we present the configuration that drives the CUT inputs When $A[i] = 1$ is required $Set[i] = 1$ and $Reset[i] = 0$ and hence $A[i] = 1$ and $B[i] = 0$ Then the output is equal to 1, and C_{in} is transferred to C_{out} .

In Fig. 2(b) we present the configuration that drives the CUT inputs When $A[i] = 0$ is required $Set[i] = 0$ and $Reset[i] = 1$ and hence $A[i] = 0$ and $B[i] = 1$ Then the output is equal to 1, and C_{in} is transferred to C_{out} .

In Fig. 2(c), we present the configuration that drives the CUT inputs when $A[i] = 0$ is required $Set[i] = 0$ and $Reset[i] = 0$. The D

input of the flip-flop of register B is driven by either 1 or 0, depending on the value that will be added to the accumulator inputs in order to generate satisfactorily random patterns to the inputs of the CUT.

In Fig. 3, the general configuration of the proposed scheme is presented. The Logic module provides the $Set[n-1:0]$ and $Reset[n-1:0]$ signals that drive the S and R inputs of the Register A and Register B inputs. Note that the signals that drive the S inputs of the flip-flops of Register A, also drive the R inputs of the flip-flops of Register B and vice versa.

Fig. 2. Configurations of the accumulator cell of Fig. 1. Are represented in the following forms a, b and figure c as follows.

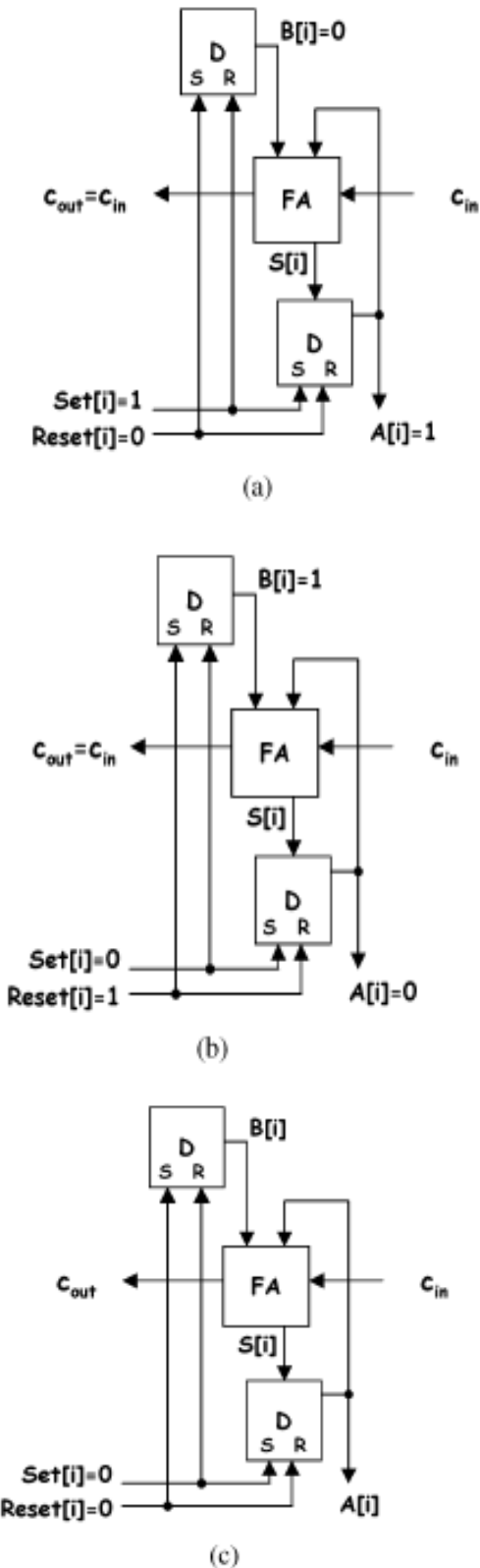

Fig. 2. a , b , c Configurations of the accumulator cell of Fig. 1.

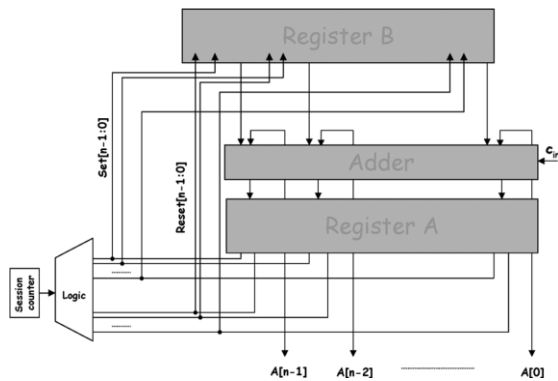

Fig. 3. Proposed scheme

IV. IMPLEMENTATION AND RESULTS

The proposed Low hardware Accumulator Based 3-Weight Pattern Generation for Boundary Scan designed using Verilog hardware description language and structural form of coding. The proposed system simulation results are as follows

Simulation Results

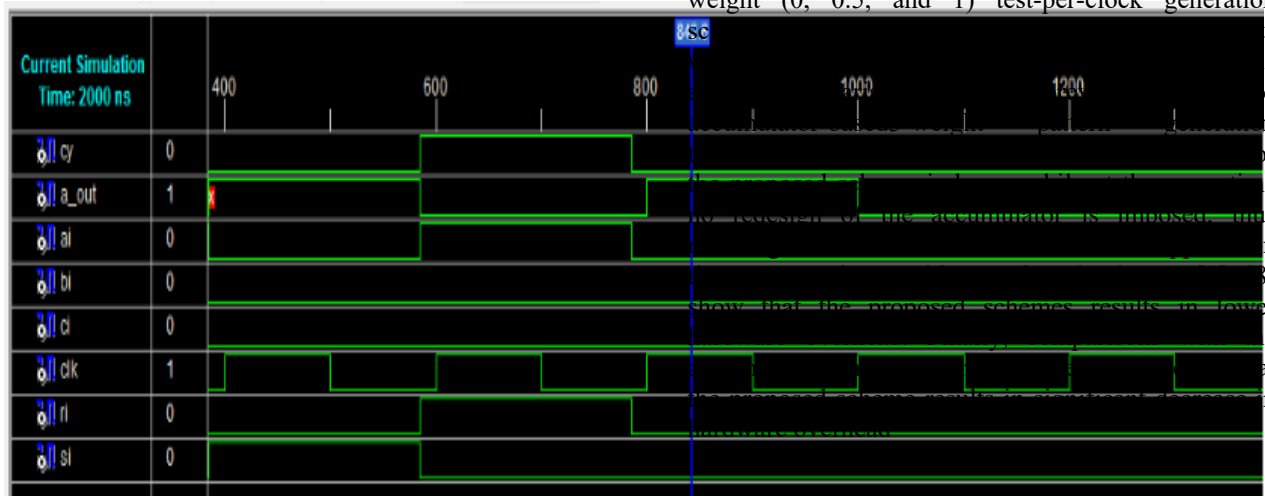

Figure.1 result of accumulator cell

when $si = 1$ $ri = 0$, and $ai = 0$ is required then we will get the $cy = 0$ that will be transferred to the output and $a_out = 1$. when $si = 0$, $ri = 1$, and $ai = 1$ is required then we will get the $cy = 1$ that will be transferred to the output and $a_out = 0$ when $si = 0$, $ri = 0$, and $ai = 0$ is required then we will get the $cy = 0$ that will be transferred to the output and $a_out = 1$

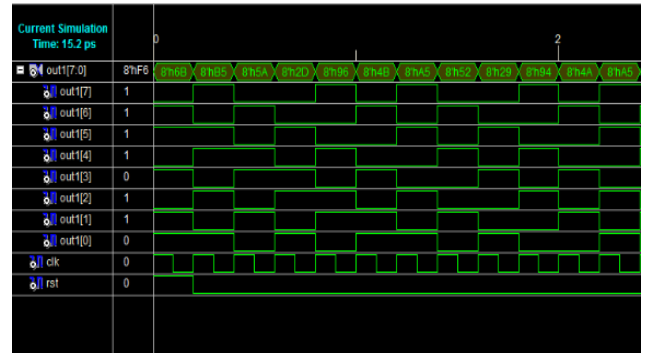

Figure.2 result of 3 weighted pattern generation

The proposed system contains of season counter and lfsr (linear feedback shift register). Which is used to produce internal signals for the different combinations . it produces different combinations of test patterns for given any circuit.

V. CONCLUSION

We have presented an accumulator-based 3-weight (0, 0.5, and 1) test-per-clock generation

REFERENCES

[1] P. Bardell, W. McAnney, and J. Savir, Built-In Test For VLSI: Pseudorandom Techniques. New York: Wiley, 1987.

[2] P. Hortensius, R. McLeod, W. Pries, M. Miller, and H. Card, "Cellular automata-based pseudorandom generators for built-in self test," IEEE Trans. Comput.-Aided Des. Integr. Circuits Syst., vol. 8, no. 8, pp. 842–859, Aug. 1989.

[3] A. Stroele, "A self test approach using accumulators as test pattern generators," in Proc. Int. Symp. Circuits Syst., 1995, pp. 2120–2123.

[4] H. J. Wunderlich, "Multiple distributions for biased random test patterns," in Proc. IEEE Int. Test Conf., 1988, pp. 236–244.

[5] I. Pomeranz and S. M. Reddy, "3 weight pseudo-random test generation based on a deterministic test set for combinational and sequential circuits," IEEE Trans. Comput.-Aided Des. Integr. Circuits Syst., vol. 12, no. 7, pp. 1050–1058, Jul. 1993.

[6] K. Radecka, J. Rajski, and J. Tyszer, "Arithmetic built-in self-test for DSP cores," IEEE Trans. Comput.-Aided Des. Integr. Circuits Syst. vol. 16, no. 11, pp. 1358–1369, Nov. 1997.

[7] J. Rajski and J. Tyszer, Arithmetic Built-In Self Test For Embedded Systems. Upper Saddle River, NJ: Prentice Hall PTR, 1998.

[8] S. Wang, "Low hardware overhead scan based 3-weight weighted random BIST," in Proc. IEEE Int. Test Conf., 2001, pp. 868–877.

[9] S. Zhang, S. C. Seth, and B. B. Bhattacharya, "Efficient test compaction for pseudo-random testing," in Proc. 14th Asian Test Symp., 2005, pp. 337–342. [10] J. Savir, "Distributed generation of weighted random patterns," IEEE Trans. Comput., vol. 48, no. 12, pp. 1364–1368, Dec. 1999.

[10] J. Savir, "Distributed generation of weighted random patterns," IEEE Trans. Comput., vol. 48, no. 12, pp. 1364–1368, Dec. 1999.

[11] I. Voyiatzis, D. Gizopoulos, and A. Paschalis, "Accumulator-based weighted pattern generation," presented at the IEEE Int. Line Test Symp., Saint Raphael, French Riviera, France, Jul. 2005.

[12] F. Brglez and H. Fujiwara, "A neutral net list of 10 combinational benchmarks circuits and a target translator in FORTRAN," presented at the Int. Symp. Circuits Syst., Kyoto, Japan, 1985

AUTHORS

First Author- Mr. K. Madan Mohan, M.Tech, Asst.Professor in the Department of Electronics and Communication Engineering, Intell Engineering College. Areas of interests are VLSI System Design, wireless sensors, Digital systems and embedded systems.

Email address: kamatimadan@gmail.com



Second Author – Abdul Junaid, received his Bachelor of Technology in Electronics and Communication Engineering in JNTUA College of engineering pulivendula, A.P., INDIA in 2011. His research area is on Low hardware Accumulator Based 3-Weight Pattern Generation for Boundary Scan under the guidance of Mr. K. Madan Mohan. His areas of interests are doing VERILOG HDL based projects.

Email: junaidiec5@gmail.com

Correspondence Author :
kamatimadan@gmail.com,
junaidiec5@gmail.com

Contact us on: (+91)-9866192802.

(+91)-9912397862.