

# Bridgeless- Luo Converter based Power Factor Correction of BLDC Drive using Fuzzy Logic Controller

Jonnada Ramana & Mr. Lakshmana Nayak

M-tech Student Scholar Department of Electrical & Electronics Engineering, Vikas college of engineering and technology, Nunna; Krishna (Dt); A.P, India.

Email:jonnadaramana24@gmail.com

MTECH

Associate Professor Department of Electrical & Electronics Engineering, Vikas college of engineering and technology, Nunna; Krishna (Dt); A.P, India.

Email:lakshmananayak@gmail.com

**Abstract-** A PFC based BL-Luo converter-fed BLDC motor drive has been proposed for a wide range of speeds and supply voltages. A single voltage sensor-based speed control of the BLDC motor using a concept of variable dc-link voltage has been used. The PFC BL-Luo converter has been designed to operate in DICM and to act as an inherent power factor pre-regulator. An electronic commutation of the BLDC motor has been used which utilizes a low-frequency operation of VSI for reduced switching losses. The speed of the BLDC motor is controlled by an approach of variable dc-link voltage, which allows a low-frequency switching of the voltage source inverter for the electronic commutation of the BLDC motor, thus offering reduced switching losses. The proposed BLDC motor drive is designed to operate over a wide range of speed control with an improved power quality at ac mains. Fuzzy logic controller, in most instances, provides a superior performance to PI controller. However, it needs to be trained properly; anything that doesn't pertain to the behavior of intended system will fail you. Fuzzy is more forgiving than PI when the system deviates from its expected operating state. Fuzzy logic is widely used in machine control. The term "fuzzy" refers to the fact that the logic involved can deal with concepts that cannot be expressed as the "true" or "false" but rather as "partially true". Although alternative approaches such as genetic algorithms and neural networks can perform just as well as fuzzy logic in many cases, fuzzy logic has the advantage that the solution to the problem can be cast in terms that human operators can understand, so that their experience can be used in the design of the controller. The proposed concept can be implemented to fuzzy based torque ripple minimization MATLAB/SIMULINK software.

**Index Terms—**Bridgeless Luo (BL-Luo) converter, brushless dc (BLDC) motor, power factor correction (PFC), power quality, voltage source inverter (VSI).

## I. INTRODUCTION

Since 1980's a new plan idea of changeless magnet brushless engines has been created. The Changeless magnet brushless engines are ordered into two sorts based upon the back EMF waveform, brushless Air conditioning (BLAC) and brushless DC (BLDC) engines [1-2]. BLDC engine has trapezoidal back EMF and semi rectangular current waveform. BLDC engines are quickly getting to be well known in businesses, for example, Appliances, HVAC industry, restorative, electric footing, car, airplanes, military gear, hard plate

drive, mechanical computerization gear and instrumentation due to their high effectiveness, high power element, noiseless operation, minimized, dependability and low support [3-5]. To supplant the capacity of commutator and brushes, the BLDC engine requires an inverter and a position sensor that distinguishes rotor position for legitimate substitution of current.

The revolution of the BLDC engine is in light of the criticism of rotor position which is gotten from the corridor sensors [6]. BLDC engine ordinarily employments three lobby sensors for deciding the recompense Grouping. In BLDC engine the force misfortunes are in the stator where warmth can be effectively exchanged through the edge or cooling frameworks are utilized as a part of expansive machines [7-8]. BLDC engines have numerous focal points over DC engines and prompting engines. A percentage of the favorable circumstances are better speed versus torque qualities, high element reaction, high proficiency, long working life, quiet operation; higher pace ranges [9]. Up to now, more than 80% of the controllers are PI (Relative and vital) controllers on the grounds that they are effortless and straightforward.

The velocity controllers are the routine PI controllers and current controllers are the P controllers to accomplish superior commute [10]. Can be considered as scientific hypothesis joining multi esteemed rationale, likelihood hypothesis, and counterfeit consciousness to recreate the human approach in the arrangement of different issues by utilizing an estimated thinking to relate diverse information sets and to make choices [11]. It has been accounted for that fluffy controllers are more powerful to plant parameter changes than traditional PI or controllers and have better clamor dismissal capacities [12].

This paper presents a BL Lou converter fed BLDC motor drive with variable dc link voltage of VSI for improved power quality at ac mains with reduced

components and superior control [13].

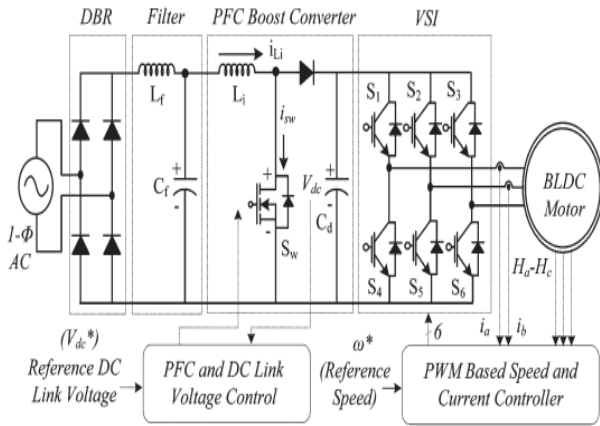

Fig. 1. Conventional PFC-based BLDC motor drive.

## II. PROPOSED PFC-BASED BLDC MOTOR DRIVE

Fig. 2 shows the proposed PFC-based bridgeless Luo (BL-Luo) converter-fed BLDC motor drive. A single phase supply followed by a filter and a BL-Luo converter is used to feed a VSI driving a BLDC motor. The BL-Luo converter is designed to operate in DICM to act as an inherent power factor preregulator. The speed of the BLDC motor is controlled by adjusting the dc-link voltage of VSI using a single voltage sensor. This allows VSI to operate at fundamental frequency switching (i.e., electronic commutation of the BLDC motor) and hence has low switching losses in it, which are considerably high in a PWM-based VSI feeding a BLDC motor. The proposed scheme is designed, and its performance is simulated for achieving an improved power quality at ac mains for a wide range of speed control and supply voltage variations. Finally, the simulated performance of the proposed drive is validated with test results on a developed prototype of the drive.

### III. OPERATING PRINCIPLE OF PFC BL-LUO CONVERTER

The operation of the proposed PFC BL-Luo converter is classified into two parts which include the operation during the positive and negative half cycles of supply voltage [see Fig. 3(a)–(c) and (d)–(f)] and during the complete switching cycle.

#### A. Operation during Positive and Negative Half Cycles of Supply Voltage

Fig. 3(a)–(c) and (d)–(f) shows the operation of the PFC BL-Luo converter for positive and negative half cycles of supply voltage, respectively. The bridgeless converter is designed such that two different switches operate for positive and negative half cycles of supply voltages. As shown in Fig. 5(a), switch  $S_{w1}$ , inductors  $L_{i1}$  and  $L_{i2}$ , and diodes  $D_p$  and  $D_{p1}$  conduct during the positive half cycle of supply voltage. In a similar manner, switch  $S_{w2}$ , inductors  $L_{i2}$  and  $L_{o2}$ , and diodes  $D_n$  and  $D_{n1}$  conduct during the negative half cycle of supply voltage as shown in Fig. 5(d). Fig. 6(a) shows the associated waveforms demonstrating the variation of different parameters such as supply voltage ( $V_s$ ),

discontinuous input inductor currents ( $i_{Li1}$  and  $i_{Li2}$ ), output inductor current ( $i_{Lo1}$  and  $i_{Lo2}$ ), and the intermediate capacitor's voltage ( $V_{C1}$  and  $V_{C2}$ ) during the complete cycle of supply voltage.

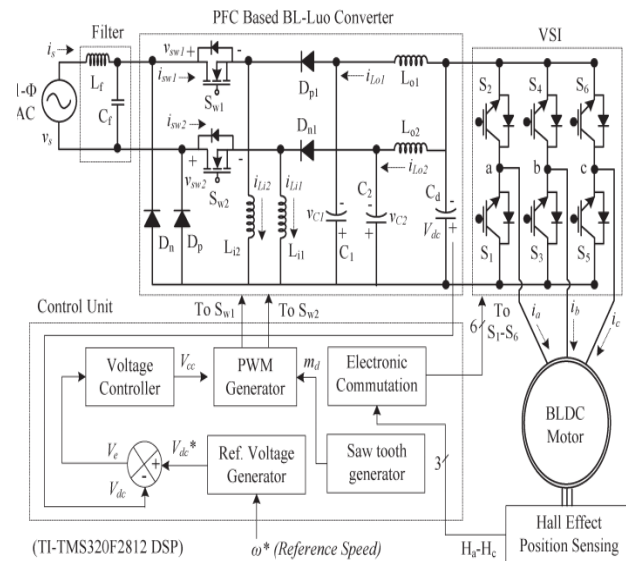
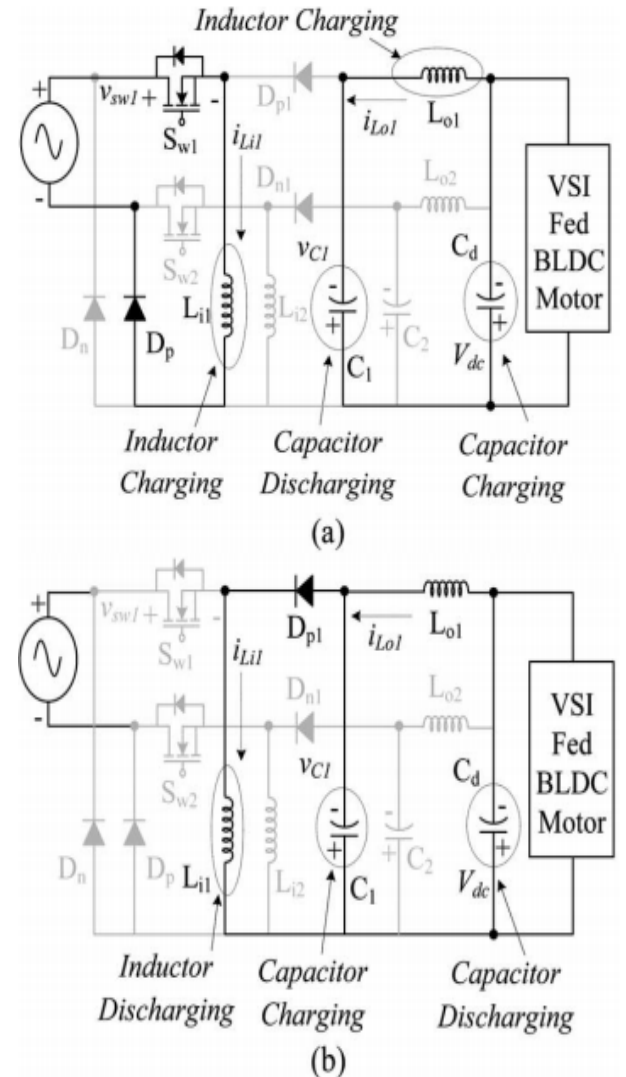

Fig. 2. Proposed PFC BL-Luo converter-fed BLDC motor drive.



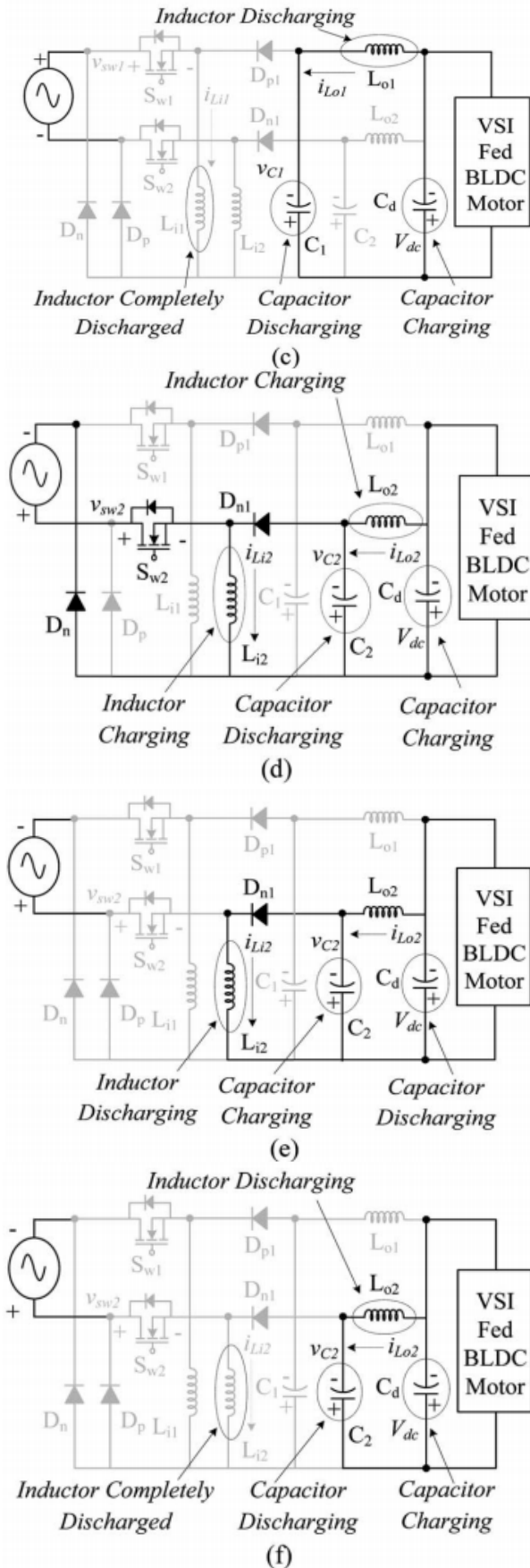

Fig. 3. Different modes of operation of the PFC BL-Luo converter during (a-c) positive and (d-f) negative half cycles of supply voltage.

(a) Mode P-I. (b) Mode P-II. (c) Mode P-III. (d) Mode N-I. (e) Mode N-II. (f) Mode N-III.

### B. Operation during Complete Switching Cycle

Fig. 4(b) shows the operation of the PFC BL-Luo converter during a complete switching period for a positive half cycle of supply voltage.

**Mode P-I:** As shown in Fig. 3(a), when switch  $S_{w1}$  is turned on, the input side inductor ( $L_{i1}$ ) stores energy, depending upon the current ( $i_{Li1}$ ) flowing through it and the inductor value ( $L_{i1}$ ). Moreover, the energy stored in the intermediate capacitor ( $C_1$ ) is transferred to the dc-link capacitor ( $C_d$ ) and the outputside inductor ( $L_{i0}$ ). Hence, the voltage across the intermediate capacitor ( $V_{C1}$ ) decreases, whereas the current in the output inductor ( $i_{Lo1}$ ) and the dc-link voltage ( $V_{dc}$ ) are increased as shown in Fig. 4(b).

**Mode P-II:** As shown in Fig. 3(b), when switch  $S_{w1}$  is turned off, the input side inductor ( $L_{i1}$ ) transfers its energy to the intermediate capacitor ( $C_1$ ) via diode  $D_{p1}$ . Hence, the current  $i_{Li1}$  decreases until it reaches zero, whereas the voltage across the intermediate capacitor ( $V_{C1}$ ) increases as shown in

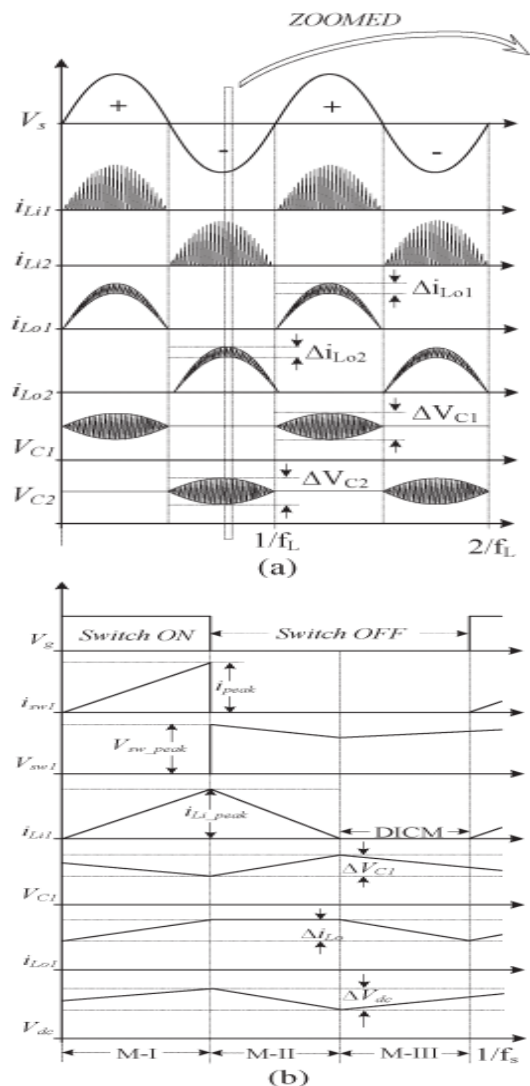

Fig. 4. Waveforms of BL-Luo converter during its operation for (a) complete line cycle and (b) complete switching cycle.

Fig. 4(b). The dc-link capacitor ( $C_d$ ) provides the required energy to the load; hence, the dc-link voltage  $V_{dc}$  reduces in this mode of operation.

Mode P-III: As shown in Fig. 3(c), no energy is left in the input inductor ( $L_{i1}$ ), i.e., current  $i_{Li1}$  becomes zero and enters the discontinuous conduction mode of operation. The intermediate capacitor ( $C_1$ ) and output inductor ( $L_{o1}$ ) are discharged; hence, current  $i_{Lo1}$  and voltage  $V_{C1}$  are reduced, and dc-link voltage  $V_{dc}$  increases in this mode of operation as shown in Fig. 4(b). The operation is repeated when switch  $Sw1$  is turned on again. In a similar way, for a negative half cycle of supply voltage, the inductor's  $L_{i2}$  and  $L_{o2}$ , diode  $D_{n1}$ , and intermediate capacitor  $C_2$  conduct to achieve a desired operation.

#### IV. CONTROL OF PFC BL-LUO CONVERTER-FED BLDC MOTOR DRIVE

The control of the PFC BL-Luo converter-fed BLDC motor drive is classified into two parts as follows.

##### A. Control of Front-End PFC Converter: Voltage Follower Approach

The control of the front-end PFC converter generates the PWM pulses for the PFC converter switches ( $S_{w1}$  and  $S_{w2}$ ) for dc-link voltage control with PFC operation. A single voltage control loop (voltage follower approach) is utilized for the PFC BL-Luo converter operating in DICM. A reference dc-link voltage ( $V_{dc}^*$ ) is generated as

$$V_{dc}^* = k_v \omega^* \quad (1)$$

Where  $K_v$  and  $\omega^*$  are the motor's voltage constant and reference speed.

The reference dc-link voltage ( $V_{dc}^*$ ) is compared with the sensed dc-link voltage ( $V_{dc}$ ) to generate the voltage error signal ( $V_e$ ) given as

$$V_e(k) = V_{dc}^*(k) - V_{dc}(k) \quad (2)$$

Where  $k$  represents the  $k^{th}$  sampling instant.

This error-voltage signal ( $V_e$ ) is given to the voltage proportional-integral (PI) controller to generate a controlled output voltage ( $V_{cc}$ ) as

$$V_{cc}(k) = V_{cc}(k-1) + k_p \{V_e(k) - V_e(k-1)\} + k_i V_e(k) \quad (3)$$

Where  $K_p$  and  $K_i$  are the proportional and integral gains of the voltage PI controller. Finally, the output of the voltage controller is compared with a high frequency saw tooth signal ( $m_d$ ) to generate the PWM pulses as

$$\begin{cases} \text{if } m_d(t) < V_{cc}(t) \text{ then } S_{w1} = S_{w2} = \text{"ON"} \\ \text{if } m_d(t) \geq V_{cc}(t) \text{ then } S_{w1} = S_{w2} = \text{"OFF"} \end{cases} \quad (4)$$

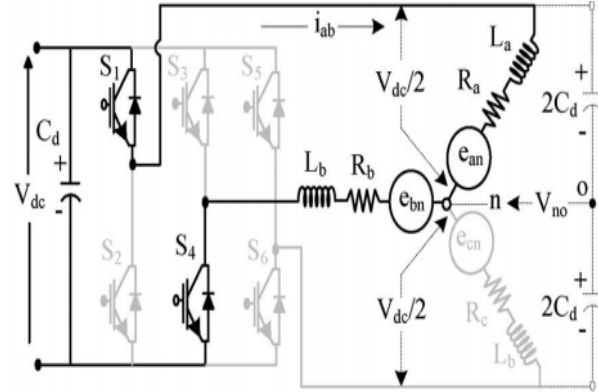

Fig. 5. VSI feeding a BLDC motor.

Table I

Switching States of VSI to Achieve Electronic Commutation of BLDC Motor

$\theta(^\circ)$	Hall Signals			Switching States					
	$H_a$	$H_b$	$H_c$	$S_1$	$S_2$	$S_3$	$S_4$	$S_5$	$S_6$
NA	0	0	0	0	0	0	0	0	0
0-60	0	0	1	1	0	0	0	0	1
60-120	0	1	0	0	1	1	0	0	0
120-180	0	1	1	0	0	1	0	0	1
180-240	1	0	0	0	0	0	1	1	0
240-300	1	0	1	1	0	0	1	0	0
300-360	1	1	0	0	1	0	0	1	0
NA	1	1	1	0	0	0	0	0	0

Where  $Sw1$  and  $Sw2$  represent the switching signals to the switches of the PFC converter. The modeling and stability issue of the proposed converter are discussed in the Appendix.

##### B. Control of BLDC Motor: Electronic Commutation

An electronic commutation of the BLDC motor includes the proper switching of VSI in such a way that a symmetrical dc current is drawn from the dc-link capacitor for  $120^\circ$  and placed symmetrically at the center of each phase. A rotor position on a span of  $60^\circ$  is required for electronic commutation, which is sensed by Hall Effect position sensors. The conduction states of two switches ( $S_1$  and  $S_4$ ) are shown in Fig. 5. A line current  $i_{ab}$  is drawn from the dc-link capacitor, whose magnitude depends on the applied dc-link voltage ( $V_{dc}$ ), back electromotive forces (EMFs) ( $e_{an}$  and  $e_{bn}$ ), resistance ( $R_a$  and  $R_b$ ), and self- and mutual inductances ( $L_a$ ,  $L_b$ , and  $M$ ) of the stator windings. Table I shows the governing switching states of the VSI feeding a BLDC motor based on the Hall Effect position signals ( $H_a-H_c$ ).

#### V. INTRODUCTION TO FUZZY LOGIC CONTROLLER

L. A. Zadeh presented the first paper on fuzzy set theory in 1965. Since then, a new language was developed to describe the fuzzy properties of reality, which are very difficult and sometime even impossible to be described using conventional methods. Fuzzy set theory has been widely used in the control area with some application to dc-to-dc converter system. A simple fuzzy logic control is built up by a group of rules based on the human knowledge of system behavior.

Matlab/Simulink simulation model is built to study the dynamic behavior of dc-to-dc converter and performance of proposed controllers. Furthermore, design of fuzzy logic controller can provide desirable both small signal and large signal dynamic performance at same time, which is not possible with linear control technique. Thus, fuzzy logic controller has been potential ability to improve the robustness of dc-to-dc converters. The basic scheme of a fuzzy logic controller is shown in Fig 5 and consists of four principal components such as: a fuzzification interface, which converts input data into suitable linguistic values; a knowledge base, which consists of a data base with the necessary linguistic definitions and the control rule set; a decision-making logic which, simulating a human decision process, infer the fuzzy control action from the knowledge of the control rules and linguistic variable definitions; a de-fuzzification interface which yields non fuzzy control action from an inferred fuzzy control action [10].

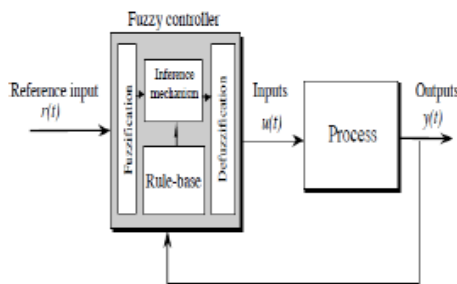

. General Structure of the fuzzy logic controller on closed-loop system  
The fuzzy control systems are based on expert knowledge that converts the human linguistic concepts into an automatic control strategy without any complicated mathematical model [10]. Simulation is performed in buck converter to verify the proposed fuzzy logic controllers.

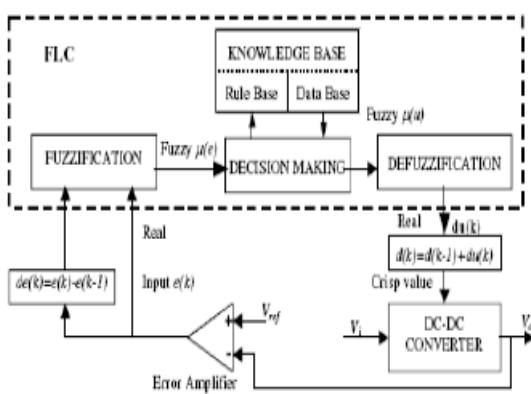

. Block diagram of the Fuzzy Logic Controller (FLC) for dc-dc converters

**A. Fuzzy Logic Membership Functions:**

The dc-dc converter is a nonlinear function of the duty cycle because of the small signal model and its control method was applied to the control of boost converters. Fuzzy controllers do not require an exact mathematical model. Instead, they are designed based on general knowledge of the plant. Fuzzy controllers are designed

to adapt to varying operating points. Fuzzy Logic Controller is designed to control the output of boost dc-dc converter using Mamdani style fuzzy inference system. Two input variables, error (e) and change of error (de) are used in this fuzzy logic system. The single output variable (u) is duty cycle of PWM output.

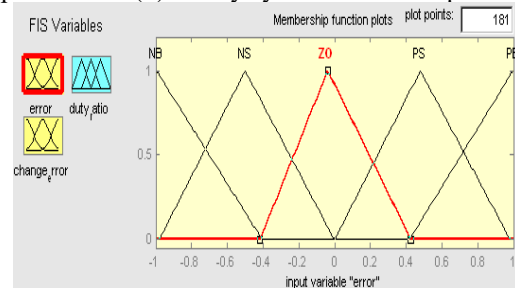

.The Membership Function plots of error

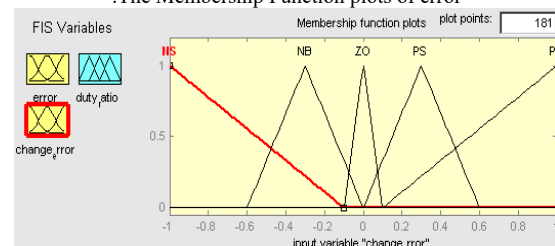

. The Membership Function plots of change error

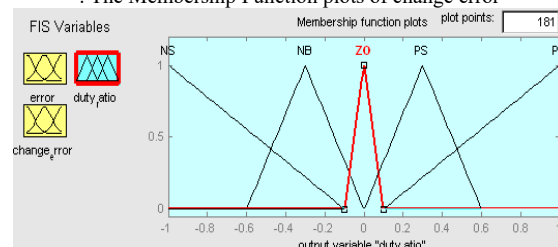

the Membership Function plots of duty ratio

**B. Fuzzy Logic Rules:**

The objective of this dissertation is to control the output voltage of the boost converter. The error and change of error of the output voltage will be the inputs of fuzzy logic controller. These 2 inputs are divided into five groups; NB: Negative Big, NS: Negative Small, ZO: Zero Area, PS: Positive small and PB: Positive Big and its parameter [10]. These fuzzy control rules for error and change of error can be referred in the table that is shown in Table II as per below:

Table II

Table rules for error and change of error

(de) \ (e)	NB	NS	ZO	PS	PB
NB	NB	NB	NB	NS	ZO
NS	NB	NB	NS	ZO	PS
ZO	NB	NS	ZO	PS	PB
PS	NS	ZO	PS	PB	PB
PB	ZO	PS	PB	PB	PB

### V.MATLAB/SIMULATION RESULTS

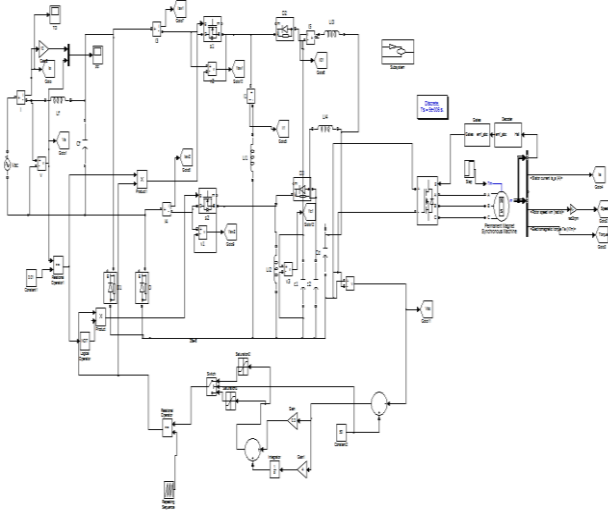

Fig.6. Matlab/Simulation model of bridge less Lou converter fed BLDC Motor.

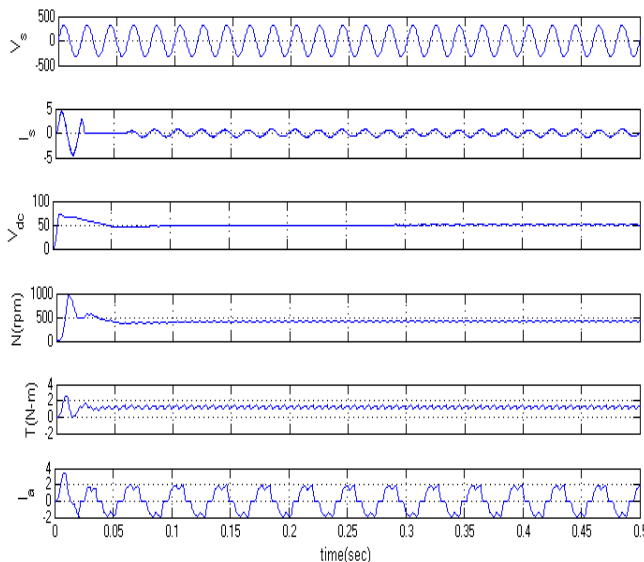

Fig.7. Simulink results of proposed BLDC motor drive At rated load torque on BLDC motor with  $V_{dc} = 50$  V and  $V_s = 220$  V.

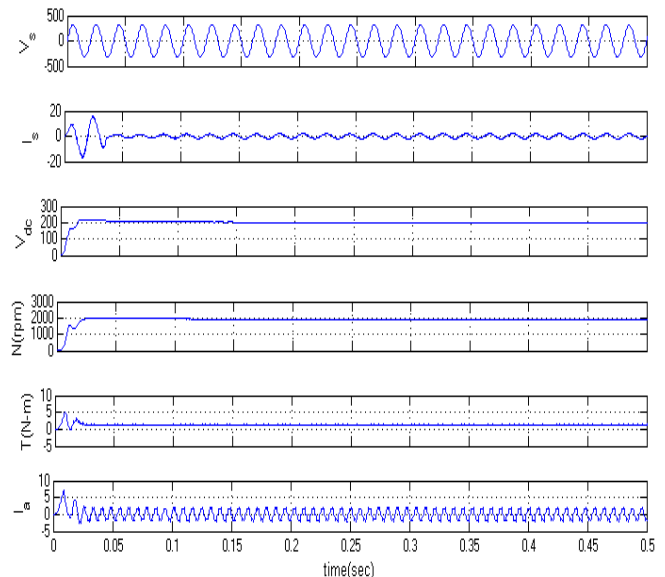

Fig.8. Simulink results of proposed BLDC motor drive At rated load torque on BLDC motor with  $V_{dc} = 200$  V and  $V_s = 220$  V.

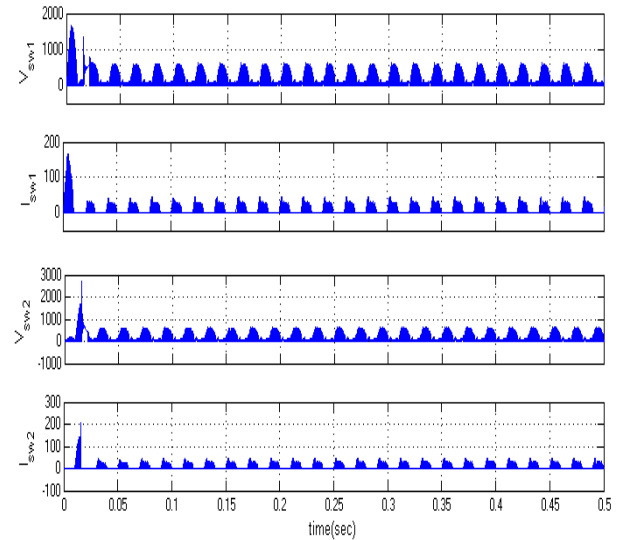

Fig.9. Simulink results of  $I_{sw1}$ ,  $V_{sw1}$ ,  $I_{sw2}$  &  $V_{sw2}$ .

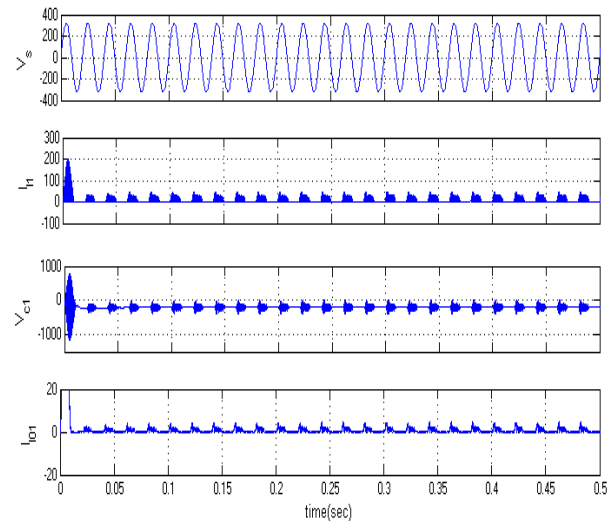

Fig.10. Simulink results of  $V_s$ ,  $I_{i1}$ ,  $V_{c1}$  &  $I_{i01}$ .

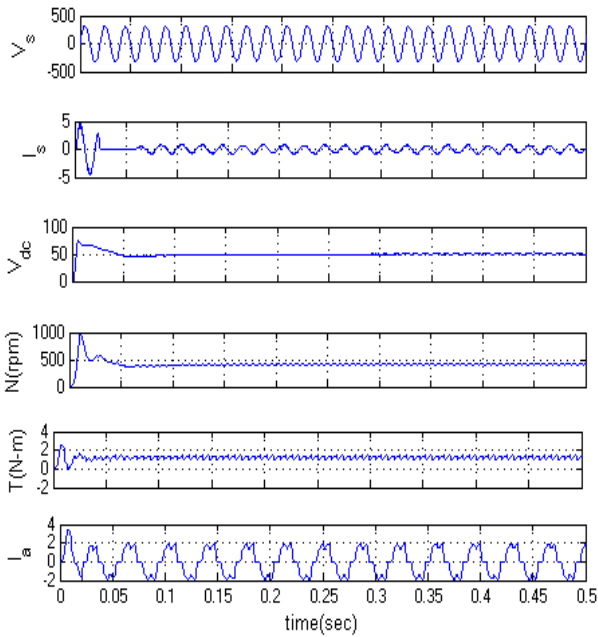

Fig.11. Simulink results of proposed BLDC motor drive showing dynamic performance during starting at 50 V.

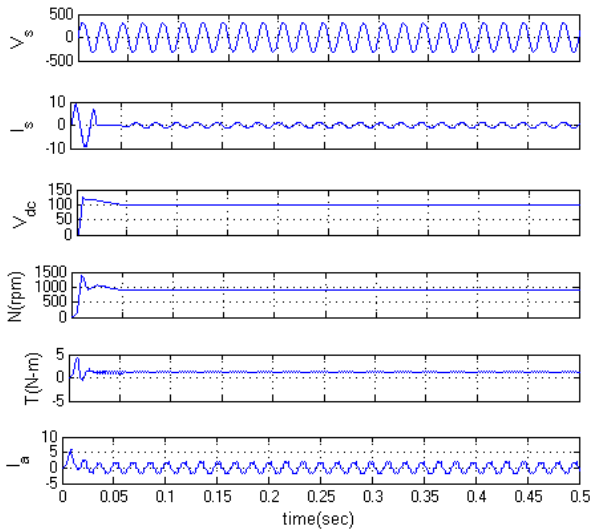

Fig.12. Simulink results of proposed BLDC motor drive showing dynamic performance during change in dc-link voltage from 100 to 150 V.

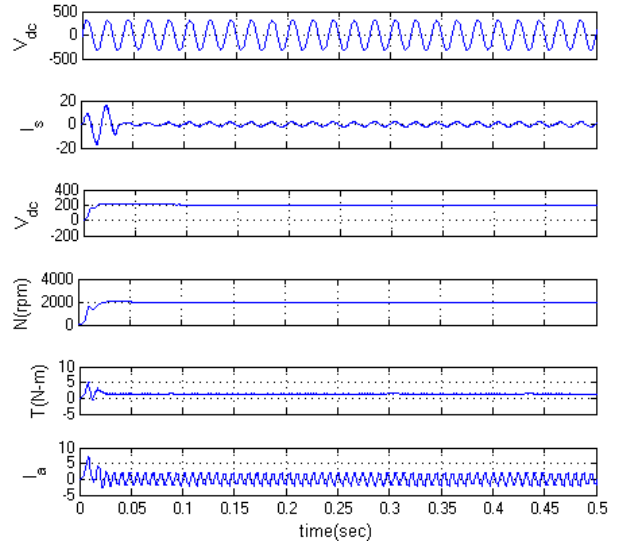

Fig.13. Simulink results of proposed BLDC motor drive showing dynamic performance of the during change in supply voltage from 250 to 180

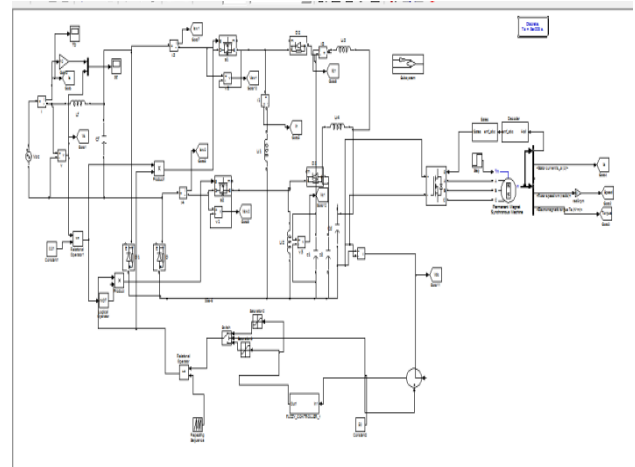

Fig 14 Matlab/Simulation model of bridge less Lou converter fed BLDC Motor with fuzzy logic controller

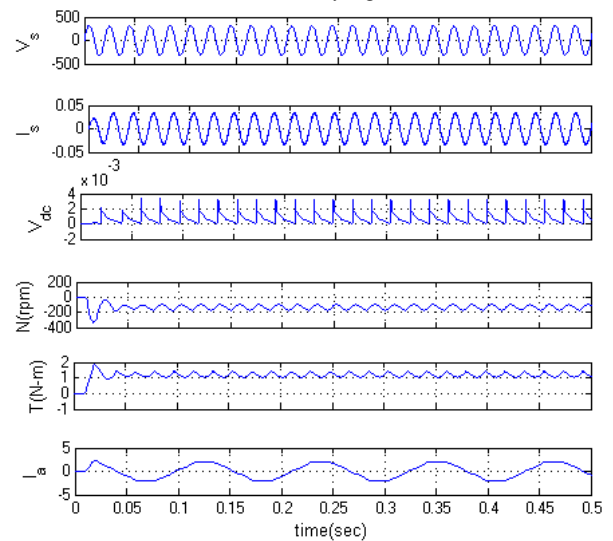

Fig 15 Simulation wave form of output performance voltage current, dc voltage and speed torque

### VI.CONCLUSION

A PFC BL-Lou converter-based VSI-fed BLDC motor drive has been proposed targeting low-power

applications. A new method of speed control has been utilized by controlling the voltage at dc bus and operating the VSI at fundamental frequency for the electronic commutation of the BLDC motor for reducing the switching losses in VSI. The front-end BLDC converter has been operated in DICM for achieving an inherent power factor correction at ac mains. Moreover, voltage and current stresses on the based PFC switch have been evaluated for determining the practical application of the proposed scheme. Finally, simulations of the proposed drive has been developed to validate the performance of the fuzzy logic controller is proposed BLDC motor drive under speed control with improved power quality at ac mains. The proposed scheme has shown satisfactory performance, and it is a recommended solution applicable to low-power BLDC motor drives.

#### REFERENCES

- [1].Bhim Singh, Fellow, IEEE, Vashist Bist, Student Member, IEEE, Ambrish Chandra, Fellow, IEEE, and Kamal Al-Haddad, Fellow, IEEE” Power Factor Correction in Bridgeless-Luo Converter-Fed BLDC Motor Drive” IEEE TRANSACTIONS ON INDUSTRY APPLICATIONS, VOL. 51, NO. 2, MARCH/APRIL 2015
- [2] C. L. Xia, Permanent Magnet Brushless DC Motor Drives and Controls. Beijing, China: Wiley, 2012.
- [3] T. Kenjo and S. Nagamori, Permanent Magnet Brushless DC Motors. Oxford, U.K.: Clarendon, 1985.
- [4] R. Krishnan, Electric Motor Drives: Modeling, Analysis and Control. New Delhi, India: Pearson Education, 2001.
- [5] T. J. Sokira and W. Jaffe, Brushless DC Motors: Electronic Commutation and Control. Blue Ridge Summit, PA, USA: Tab Books, 1989.
- [6] H. A. Toliyat and S. Campbell, DSP-Based Electromechanical Motion Control. New York, NY, USA: CRC Press, 2004.
- [7] S. Singh and B. Singh, “A voltage-controlled PFC Cuk converter based PMBLDCM drive for air-conditioners,” IEEE Trans. Ind. Appl., vol. 48, no. 2, pp. 832–838, Mar./Apr. 2012.
- [8] Limits for Harmonic Current Emissions (Equipment input current  $\leq 16$  A per phase), International Std. IEC 61000-3-2, 2000.
- [9] B. Singh et al., “A review of single-phase improved power quality acdc converters,” IEEE Trans. Ind. Electron., vol. 50, no. 5, pp. 962–981, Oct. 2003.
- [10] B. Singh, S. Singh, A. Chandra, and K. Al-Haddad, “Comprehensive study of single-phase ac-dc power factor corrected converters with highfrequency isolation,” IEEE Trans. Ind. Informat., vol. 7, no. 4, pp. 540–556, Nov. 2011.
- [11] S. B. Ozturk, O. Yang, and H. A. Toliyat, “Power factor correction of direct torque controlled brushless dc motor drive,” in Conf. Rec. 42<sup>nd</sup>IEEE IAS Annu. Meeting, Sep. 23–27, 2007, pp. 297–304.
- [12] T. Y. Ho, M. S. Chen, L. H. Yang, and W. L. Lin, “The design of a high power factor brushless dc motor drive,” in Int. Symp. Comput., Consum. Control, Jun. 4–6, 2012, pp. 345–348.
- [13] T. Gopalarathnam and H. A. Toliyat, “A new topology for unipolar brushless dc motor drive with high power factor,” IEEE Trans. Power Electron., vol. 18, no. 6, pp. 1397–1404, Nov. 2003.