

# Novel Design and Completion of IPTV Service Delivery through Virtualization

---

K. V. Chaitanya Jyothi<sup>1</sup>, S. Md. Ibrahim<sup>2</sup>, S. G. Nawaz<sup>3</sup>

<sup>1</sup>M.Tech, Dept of CS, Sri Krishnadevaraya Engineering College, Gooty, AP, India

<sup>2</sup>Assistant Professor, Dept of CSE, Sri Krishnadevaraya Engineering College, Gooty, AP, India

<sup>3</sup>Associate Professor, Dept of CSE, Sri Krishnadevaraya Engineering College, Gooty, AP, India

## Abstract:

*Usage of IPTV Service conveyance through Virtualization is of pragmatic enthusiasm toward numerous applications, for example, locating an IPTV Service conveyance disappointment. The interruption location is characterized as an instrument for an IPTV Service conveyance through virtualization to discover the presence of immoral, mistaken, or atypical moving assailant (intruder)s. In this examination IPTV conveys the television content over a web Convention foundation. Virtualized cloud-based Services will advantage of statically multiplexing crosswise over applications to yield paramount expense reserve funds to the administrator the cloud based IPTV give bring down a supplier's expenses of constant IPTV benefits through a virtualized IPTV structural planning and through sagacious time moving of Service conveyance. It exploits the distinctions in the due dates connected with live television versus Video-on-Demand (VoD) to successfully multiplex these Services. In any case, accomplishing comparable favorable circumstances with time of time Services are frequently a test. For build the issue as an enhancement plan that uses a bland expense capacity. e.g., least most extreme, sunken and arched capacities to reflect the distinctive expense operation. We build the*

*issue as an advancement definition that uses a bland expense capacity. We likewise demonstrate that there are intriguing open issues in planning components that permit time-moving of burden in such situations.*

**Keywords:** *Orchestrator; Set Top Box; Video on Demand; Interactive TV; Live TV; D-Server*

## 1. INTRODUCTION

As IP-based feature conveyance gets to be more renowned, the requests places upon the Service supplier's assets have significantly gathered. Service suppliers typically procurement for the stature requests of each Service over the Supplier populace. On the other hand, provisioning for top interest leaves assets underneath utilized as a part of any appreciation elective periods. This is regularly altogether apparent with Moment Channel change (MCC) asks for in IPTV[1]. In IPTV, Live television is regularly multicast from servers misuse IP Multicast, with one bunch every Station. Video-on-Demand (VoD) is furthermore underpinned by the Service Suppliers with each one solicitation being serve by a server serving an unicast stream When clients alteration channels while perception live television, we have to give additional reasonableness to so the station

change takes sway quickly[1]. For each channel change, the client must be a piece of the multicast bunch identified with the channel, and anticipate that enough data will be cushioned before the feature is shown; this may take as much time as required. Thus, there are numerous makes an endeavor to help moment channel alteration by alleviating the client saw channel shift inactivity. With the common Moment Channel Change implemented on IPTV frameworks, the substance are conveyed at happen all the more quickly rate utilizing a unicast stream from the server. The playout support is full rapidly, thus continues exchanging inactivity little. Once the playout cradle is full up to the playout reason, the set top box action again to getting the multicast stream. Our Point is in this paper is to exploit the unique workloads of the different IPTV Services to higher use the conveyed servers. It offers opportunities for the Service supplier to convey the VoD content in expectation and

conceivably out of request, exploiting the buffering accessible at the beneficiaries. Virtualization offers us the adaptability to impart the server assets over these Services & utilize a distributed computing foundation with virtualization is moving the assets rapidly continuously to handle the moment channel change workload, b) to be prepared to expect the revision inside the work before time and preload VoD content on Set Top Boxes, in this way encourage the moving of assets from Feature on Interest to Moment Channel Change amid the blasts and c) to tackle a general expense issue of advancement definition without needing to fastidiously display each and every parameter setting in an exceedingly server farm to encourage this moving assets. In virtualized surroundings, Moment channel change is overseen by a gathering of VMS regularly; elective VMS would be made to handle Feature on Interest solicitations. With the ability to produce VMS rapidly [4].

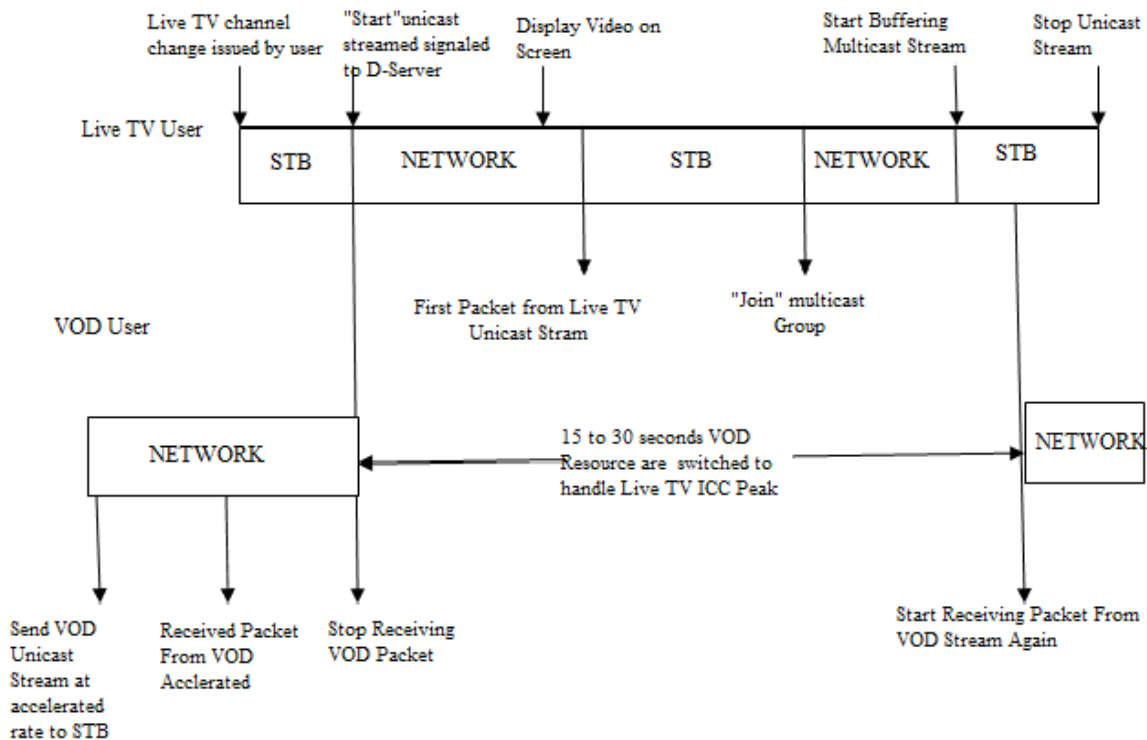

Fig1. Live TV ICC and VoD packet buffering timeline

## II. BACKGROUND

**2.1 Structure of IPTV Framework:** The IPTV building design we are actualizing this Construction modeling on. Cloud network.fig 2 demonstrates the IPTV Structural engineering and framework parts for IPTV frameworks. The dispersion system comprises of feature servers for each metropolitan space associated through the metro system of web convention switches and optical systems to the right to gain entrance network [2]. The right to gain entrance organizes by and large incorporates a tree-like dissemination system with copper or fiber (fresher situations) property to the house. In partner illustration across the nation conveyance setting, substance is gotten from the point wherever its non inheritable over a Web Convention spine to the IPTV head-end for

the metropolitan space at a Video Hub Office (VHO). From now, the feature is appropriated to supporter homes inside the metro or cloud System.

**1. Substance sources & D-Server:** Feature substance is gotten from substance suppliers either live or from capacity (for Feature on Interest). The substance is cradled at Dispersion Servers (D-Server) inside the Video Hub Office (VHO). An alternate D-server can be utilized for each one channel; all D-servers impart the connection to the Feature Center point Office, and by and large one D-server's data yield limit is of the request of ~100s of Mbps

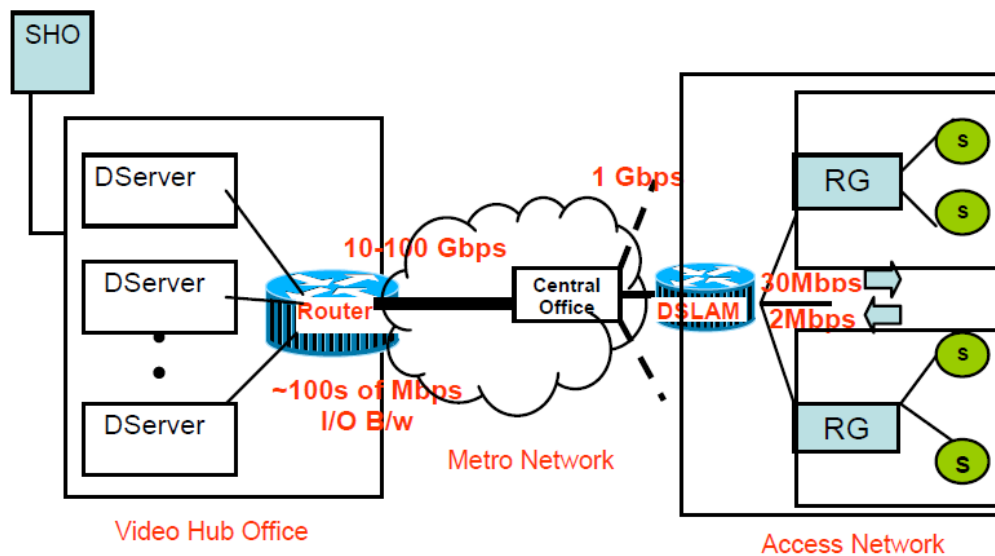

Fig. 2 IPTV Architecture

**2. Metro System or Cloud System:** it joins the VHO to assortment of Focal Office (FO). The Metro system is generally related in

nursing optical system with essential capacity. Downstream of the Focal Office

are numerous Advanced Endorser Line Access Multiplexers (AELAMS).

**3. Client access link:** Conveyance of IPTV over the "last mile" is additionally given over existing circle plant to homes exploitation higher-pace telephone line advances like Vdsl2. Service suppliers could utilize a mix of Fiber-to-the Node (FTTN) and telephone line advances or execute immediate Fiber-to-the-Home (FTTH) access.

**4. Customer Premises Mechanism (CPM):** CPM incorporates the broadband system end (B-NT) and a Private Entryway (PE). The PE is by and large a Web convention switch and is the boundary point between the Service suppliers furthermore the home system.

**5. IPTV Customer:** The IPTV purchaser (e.g., Set top Box (STB)) ends IPTV activity at the creator premises.

### 3. WORKING STANDARD

Improvement hypothesis is a numerical strategy for deciding the most beneficial or slightest disadvantageous decision out of a set of options. Dynamic advancement is a sub extension of enhancement hypothesis that arrangements with improving the obliged control variables of a discrete time dynamic framework. In this paper, we consider limited skyline improvement where the ideal control parameters with limited look-ahead are to be discovered [4] [5]. All the more particularly, we know the entry example of the IPTV and VoD demands with their due dates later on. We wish to discover the quantity of servers to use at each one time to minimize the expense capacity. In this paper, we consider diverse manifestations of expense

capacities. We determine shut structure arrangements where feasible for different expense capacities

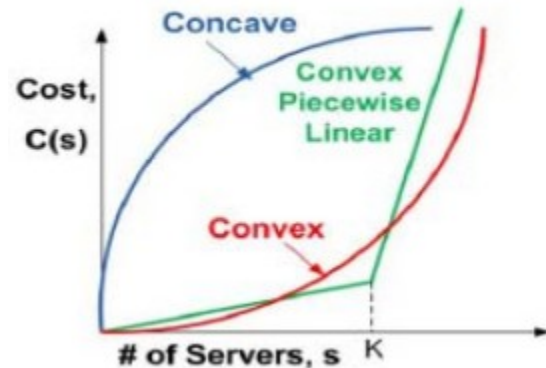

Fig 2. Cost Functions

**1) Linear Cost:**  $C(s_1, s_2, \dots, s_T) = \sum_{i=1}^T s_i$ . These representations are casing where we incur a cost that is proportional to the total number of servers needed across all times.

**2) Convex Separable Cost:**  $C(s_1, s_2, \dots, s_T) = \sum_{i=1}^T C(s_i)$ , where  $C(s_j)$  is a convex function. This models the case when a data center sees an increasing per unit cost as the number of servers required grows. We consider two examples of  $C(s_i)$ , the component cost function. The first is the exponential function,  $C(s_i) = \exp(s_i)$ . The second is a piecewise linear function of the form  $C(s_i) = s_i + c(s_i - K)^+$  where  $c, K \geq 0$ . This component cost function has preserver cost of unity when  $s_i \leq K$ , and per-server cost of  $1 + c$  thereafter.

**3) curved in discrete Cost:**  $C(s_1, s_2, \dots, s_T) = \sum_{i=1}^T C(s_i)$ , with component cost  $C(s_i)$  a concave function. This may arise when the per-server cost diminishes as the number of servers grows.

**4) Maximum Cost:**  $C(s_1, s_2, \dots, s_T) = \max_{i=1}^T s_i$ . This cost function penalizes the peak

capacity that will be needed to serve the incoming sequence of requests.

### 3.1 Advantages of cloud Based IPTV System

In Virtualized cloud Based framework there is more workload so lessening workload we are planning the Gathering Of Picture is to secure the transmission of enormous measure of information over the untrustworthy channel e.g. web remote channels and so on .Programming will conceal content record in compartment feature file[3]. Fitting compartment feature document must be chosen such that it would be plausible to transmit over web thusly feature record obliges huge data transmission The product must conceal substantial measure of information The product must encode the information before concealing it into holder media document Message concealing ought to be such that concealed message must capture table so the framework gives emulating

#### Important points

**1. Live television Controller:** Rewind, stop, play while sitting in front of the TV show because of that it is called triple play.

**2. Video-on-Demand:** IPTV innovation is bringing feature on-interest (VoD) to TV, which allows a client to peruse an online program or film inventory, to watch trailers and to then select a chose recording.

**3. Intelligence** An IP-based stage moreover allows crucial chances to structure the television seeing mastery a ton of intuitive and redid, the supplier project manages that empowers viewers to make a go at searching for substance by title or on-screen characters name, or a picture-in-picture common sense that empowers them to station surf without flight the system perception.

**4. Matters of trade and profit** In any case, in light of the fact that feature streams require a high bit rate for any longer times of your time, the consumptions to help high measures of feature movement are plenteous greater.

### 5. IPTV essentially based Joined Service

An alternate focal point of an IP-based system is that the chance for reconciliation and merging. this chance is intensified once misuse IMS-based solutions.[6] Con- skirted Services suggests association of existing Services in an exceedingly consistent way to structure new worth side Services. One case is on-screen presentation, getting show on a television furthermore the capacity to handle it (send it to phone message, and so forth.). IP-based Services can help to change endeavors to supply clients whenever anyplace get to substance over their TVs, PCs and mobile phones, and to incorporated Services and substance to them along at interims organizations and foundations, IPTV kills the necessity to run a parallel foundation to convey live and hang on feature Services.

## 4. USAGE OF IPTV

In our virtualized surroundings, ICC is overseen by a situated of VMS. The quantity of such VMS made would be determined by the indicator depicted previously. (Note that a little number of VMS would ordinarily be relegated to every unique channel). Likewise, for the VoD Service, we would design various VMS focused around the as of now dynamic VoD sessions, and would be adjusted to take care of client demand. At the point when a physical server complex is imparted for these Services, it is attractive that we minimize the aggregate number of

VMS conveyed. Along these lines the assets used to fulfill all these solicitations. The provisioning methodology portrayed above successfully utilizes virtualization to attain this minimization of asset use. Since VMS can be produced rapidly [2], the coordination method misuses the expectation to do so in suspicion of an ICC load motivation. Moreover, it causes the VoD VMS to serve existing sessions at a quicker rate before the onset of the ICC burden, and after that quiescence these VMS amid the ICC spike

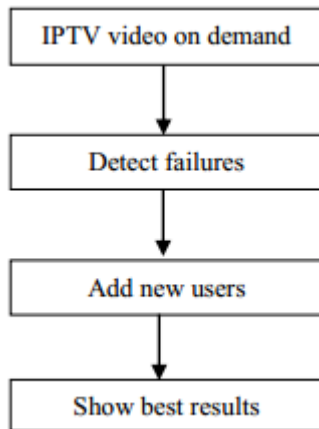

To check the accessibility and trustworthiness of outsourced information in cloud Storages, specialists have proposed two essential methodologies called Provable Data Ownership and Confirmations of Hopelessness. Ateniese et al. initially proposed the PDO model for guaranteeing ownership of records on un-trusted stockpiles and gave a RSA-based plan for a static case that attains the correspondence cost. They likewise proposed an openly undeniable adaptation, which permits anybody, not simply the manager, to test the server for information ownership. They proposed a lightweight PDO plan focused around cryptographic

hash capacity and symmetric key encryption, yet the servers can bamboozle the holders by utilizing past metadata or reactions because of the absence of haphazardness in the difficulties. The quantities of upgrades and difficulties are restricted and settled ahead of time and clients can't perform piece insertions anyplace.

## 5. SUGGETION

As a major aspect of our proposal, we would amplify our work to investigate more viable CPDP developments. At long last, it is still a testing issue for the era of labels with the length insignificant to the extent of information pieces. We would investigate such an issue to give the backing of variable length square check Our investigations obviously exhibited that our methodologies just present a little measure of reckoning and correspondence overheads. Consequently, our answer can be dealt with as another possibility for information respectability check in outsourcing information stockpiling frameworks. Programming will most likely experience change once it is conveyed to the client. There are numerous explanations behind the change. Change could happen in view of some sudden information values into the framework. Also, the progressions in the framework could specifically influence the product operations. The product ought to be created to suit changes that could happen amid the post usage period.

1. Check that the sections are of the right configuration
2. No copy passages ought to be permitted
3. All connections ought to take the client to the right page.

## 6. CONCLUSION

We mulled over however IPTV Service suppliers will influence a virtualized cloud in-frastructure and shrewd time-moving of burden to higher use sent assets. Time moving diminishes the workload also Moment Channel Change and VoD conveyance as cases. We considered that we will advantage of the refinement in workloads of IPTV Services to calendar them befittingly on virtualized framework. Detail to create as a general enhancement issue and processed the amount of servers required in accordance with a non specific quality work. We concentrated on different structures for the worth work (e.g., min-max, curved and inward) and comprehended for the best assortment of servers that are expected to help these Services while not missing any due dates. Our examination plainly affirmed that our methodologies just present a little measure of calculation and correspondence overheads. Hence, our answer can be dealt with as another possibility for information trustworthiness confirmation in outsourcing Data Storage frameworks

## REFERENCES:

[1] "Optimizing Cloud Resources for Delivering IPTV Services through Virtualization", Vaneet Aggarwal, Vijay Gopalakrishnan, Rittwik Jana, K. K. Ramakrishnan, Vinay A. Vaishampayan AT&T Labs – Research, 180 Park Ave, Florham Park, NJ, 07932

[2] D. Banodkar, K. K. Ramakrishnan, S. Kalyanaraman, A. Gerber, and O. Spatscheck, "Multicast instant channel change in IPTV system," in Proceedings of IEEE COMSWARE, January 2008.

[3] "Microsoft tv: lptv edition," <http://www.microsoft.com/tv/IPTVEdition.aspx>.

[4] H. A. Lagar-Cavilla, J. A. Whitney, A. Scannell, R. B. P. Patchin, S. M. Rumble, E. de Lara, M. Brudno, and M. Satyanarayanan, "SnowFlock: Virtual Machine Cloning as a First Class Cloud Primitive," ACM Transactions on Computer Systems (TOCS), 2011.

[5] V. Aggarwal, V. Gopalakrishnan, R. Jana, K. K. Ramakrishnan, and V. Vaishampayan, "Exploiting Virtualization for Delivering Cloud-based IPTV Services," in Proc. of IEEE INFOCOM (mini-conference), Shanghai, April 2011.

[6] R. Urgaonkar, U. Kozat, K. Igarashi, and M. J. Neely, "Dynamic resource allocation and power management in virtualized data centers," in Proceedings of IEEE IFIP NOMS, March 2010.

[7] P. Ning, S. D. C. di Vimercati, and P. F. Syverson (2007), Eds. ACM, pp. 598–609.

[8] A. Juels and B. S. K. Jr. (2007), Pors: proofs of retrievability for large files, in ACM Conference on Computer and Communications Security

[9] G. Ateniese, R. D. Pietro, L. V. Mancini, and G. Tsudik (2008), Scalable and efficient provable data possession, in Proceedings of the 4th international conference on Security and privacy in communication networks, SecureComm, pp. 1–10.

[10] C. C. Erway, A. K. Upc, U. C. Papamanthou, and R. Tamassia (2009), Dynamic provable data possession, in ACM Conference on Computer and Communications Security, pp. 213–222.

[11] H. Shacham and B. Waters (2008), Compact proofs of retrievability, in ASIACRYPT, ser. Lecture Notes in Computer

Science, J. Pieprzyk, Ed., vol. 5350. Springer, pp. 90–107.

[12] Q. Wang, C. Wang, J. Li, K. Ren, and W. Lou (2009), Enabling public verifiability and data dynamics for storage security in cloud computing, in ESORICS, ser. Lecture Notes in Computer Science, vol. 5789. Springer, pp. 355–370.

[13] Y. Zhu, H. Wang, Z. Hu, G.-J. Ahn, H. Hu, and S. S. Yau (2011), Dynamic audit services for integrity verification of outsourced storages in clouds, in SAC, pp. 1550–1557.

[14] K. D. Bowers, A. Juels, and A. Oprea (2009), Hail: a high-availability and integrity layer for cloud storage, in ACM Conference on Computer and Communications Security, pp. 187–198.

[15] Y. Dodis, S. P. Vadhan, and D. Wichs (2009), Proofs of retrievability via hardness amplification, in TCC, ser. Lecture Notes in Computer Science, vol. 5444. Springer, pp. 109–127.

[16] L. Fortnow, J. Rompel, and M. Sipser (1988), On the power of multiprover interactive protocols, in Theoretical Computer Science, pp. 156–161.

[17] Y. Zhu, H. Hu, G.-J. Ahn, Y. Han, and S. Chen (Oct 2011), Collaborative integrity verification in hybrid clouds, in IEEE Conference on the 7th International Conference on Collaborative Computing: Networking, Applications and Worksharing, CollaborateCom, Orlando, Florida, USA, 15-18, pp. 197–206.

[18] D. Boneh and M. Franklin (2001), Identity-based encryption from the weil pairing, in Advances in Cryptology (CRYPTO'2001), vol. 2139 of LNCS, , pp. 213–229..

[19] O. Goldreich (2001), Foundations of Cryptography: Basic Tools. Cambridge University Press.

#### SHORT BIOGRAPHY:



**Mrs. K. V. Chaitanya Jyothi** received the **B.Tech** Degree in Computer Science Engineering from Jawaharlal Nehru Technological University, Anantapur, in 2010.



**Mr. S. Md. Ibrahim** received the **M.Tech** Degree in Computer Science and Engineering from Jawaharlal Nehru Technological University, Anantapur, in 2012. He is having 7 years of teaching experience. He is currently working as Assistant Professor, Dept of C.S.E, SKD Engineering College, Gooty, A.P, India. He was published 5 papers in various conferences and Journals.



**Mr. S. G. Nawaz** received the **M.Tech** Degree in Computer Science and Engineering from Jawaharlal Nehru Technological University, Anantapur, in 2012. He is having 9 years of teaching experience. He is currently working as Assoc. Professor, Dept of C.S.E, SKD Engineering College, Gooty, A.P, India. He published 6 papers in various conferences and journals.