

---

## Vehicle Accident Detection and Prevention System

---

Y.Sreenidhi<sup>1</sup>, N.S.D.Prathyush<sup>2</sup>, G.J.Sabarish<sup>3</sup>, S.Daina Emerald Aasha<sup>4</sup>

<sup>1</sup>B-Tech, Department of ECE, SRM Institute Of Science and Technology

<sup>2</sup>B-Tech, Department of ECE, SRM Institute Of Science and Technology

<sup>3</sup>B-Tech, Department of ECE, SRM Institute Of Science and Technology

<sup>4</sup>Assistant Professor, Department of ECE, SRM Institute Of Science and Technology

**ABSTRACT** : *Accident prevention and detection system is used for reducing the accidents rate and its after effects providing help as soon as possible. The sensors like eye blink sensor, alcohol sensor, obstacle sensor, vibration sensor and temperature sensor are programmed to work in coordination with the engine ignition system, buzzer to avoid any accident that can occur due to drowsiness, drunk driving or over revving of engine. It uses a smart helmet that has wireless control to the ignition system. The project also concentrates on detecting an accident with the help of vibration sensor and works in coordination with GPS and GSM system to intimate the accident to preset and variable receivers and get the rescue team to the spot to provide required support.*

### INTRODUCTION :

There are many accidents occurring because of different reasons of which most of them are avoidable if we follow traffic rules and be responsible. This system forces the rider to follow traffic rules and ensures safety. This project will make the rider to wear the helmet to start the bike which is a safety feature. With the help of different sensors like alcohol sensor, temperature sensor and ultrasonic sensor the accidents caused by drunken driving, overheating problems and careless driving can be avoided. If at all any accident occurs due to

any unavoidable reasons then there are GPS and GSM modules in this to detect the accident with the help of a vibration sensor and report it with its location to get immediate help from a rescue team.

### An Arduino Based Accident Prevention And Identification System For Vehicles:

Here, an Arduino based system has been developed by using Global Positioning System (GPS) and Global System for Mobile Communication (GSM) technology. An accelerometer will also be used that will measure the velocity and the amount of the vehicle's tilting when it will struck over something. When the velocity of the car will be more than the defined maximum velocity for the road or it tilts, a warning will be given automatically.

### Vehicle Positioning System with Accident Detection Using Accelerometer Sensor and Android Technology:

Embedded technology is used to detect accident using accelerometer and android technology

is used to get the name of the location instead of getting latitudes and longitudes. Android app that specifies the location name when mobile receives the GPS data plays major role in this paper.

## An Arduino Based Accident Prevention And Identification System For Vehicles:

An Arduino based system has been developed by using Global Positioning System (GPS) and Global System for Mobile Communication (GSM) technology. An accelerometer will also be used that will measure the velocity and the amount of the vehicle's tilting when it will struck over something. When the velocity of the car will be more than the defined maximum velocity for the road or it tilts, a warning will be given automatically.

## A Smart Vehicle For Accident Prevention Using Wireless Blackbox And Eyblink Sensing Technology Along

### System Model description: Micro Controller:



ATMEL ATMEGA 328P-PU is the controller used and it is the heart of the system. Microchip ATmega328 8-bit micro controllers are high-

## With Seat Belt Controlled Ignition System:

A speed sensor, seat belt sensor and various sensors which senses various parameters of the vehicle is connected to a microcontroller which detects when the abnormal conditions occur or any accidents occur then sends text message, using GSM technology, to a police ambulance services and the drivers relatives. The text send to various authorities contains the details of the vehicle and its position.

## Smart Helmet with Sensors for Accident Prevention:

A 315 MHz Radio Frequency Module as wireless link which able to communicate between transmitter circuit and receiver circuit. PIC16F84a is a microcontroller to control the entire component in the system

general-purpose I/O lines, 32 general-purpose working registers, serial programmable USART, and more. Microchip ATmega328 MCUs execute powerful instructions in a **GSM Modem:**

single clock cycle, allowing the device to achieve throughputs approaching 1 MIPS per MHz while balancing power consumption and processing .



**Figure: GSM Modem**

Global System for Mobile (GSM) SIM800 modem RS232 is a Global Positioning System (GPS) modem that is flexible for any application that you might want. It is a quad band GSM module. It requires a voltage supply of 9 to 12VDC. It has an inbuilt antenna. It can be used in GSM based reporting systems. It has led to indicate the operation.

### **GPS Receiver:**



GPS receiver, or simply GPS is a device that is capable of receiving information from GPS satellites and then to calculate the device's geographical position. Using suitable software, the device may display the position on a map, and it may offer directions. The Global Positioning System (GPS) uses a global navigation satellite

system(GNSS) made up of a network of a minimum of 24, but currently 30, satellites. It requires a 5VDC input for its operation.

### **RF Transmitter And Receiver:**

This project uses an 8 bit RF transmitter and a receiver. This RF module comprises of an RF Transmitter and an RF Receiver. The transmitter/receiver (Tx/Rx) pair operates at a higher frequency. An Radio Frequency (RF) transmitter receives serial data and transmits it wirelessly through RF through its antenna connected at pin4. The transmission occurs at the rate of 1Kbps - 10Kbps. The transmitted data is received by an RF receiver operating at the same frequency as that of the transmitter. The transmitter gets the power from a 9V battery and receive is connected in system on bike.

### **Alcohol Sensor:**

**figure:** Alcohol Sensor

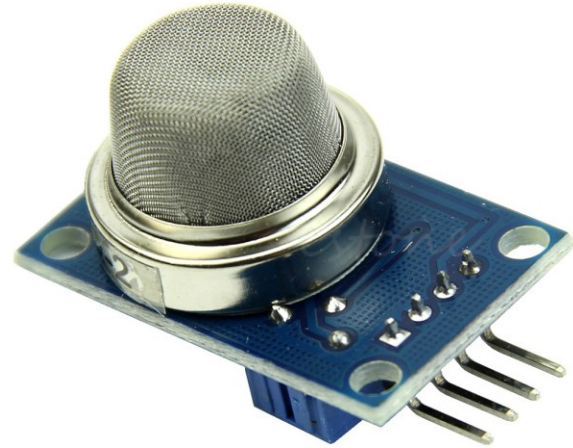

MQ2 due to its high sensitivity and fast response time, measurement can be taken as soon as possible. The sensitivity of the sensor can be adjusted by potentiometer. The voltage requirement is 5VDC. It has a heater resistance up to 30 ohm and sensing resistance up to 33 kilo ohm.

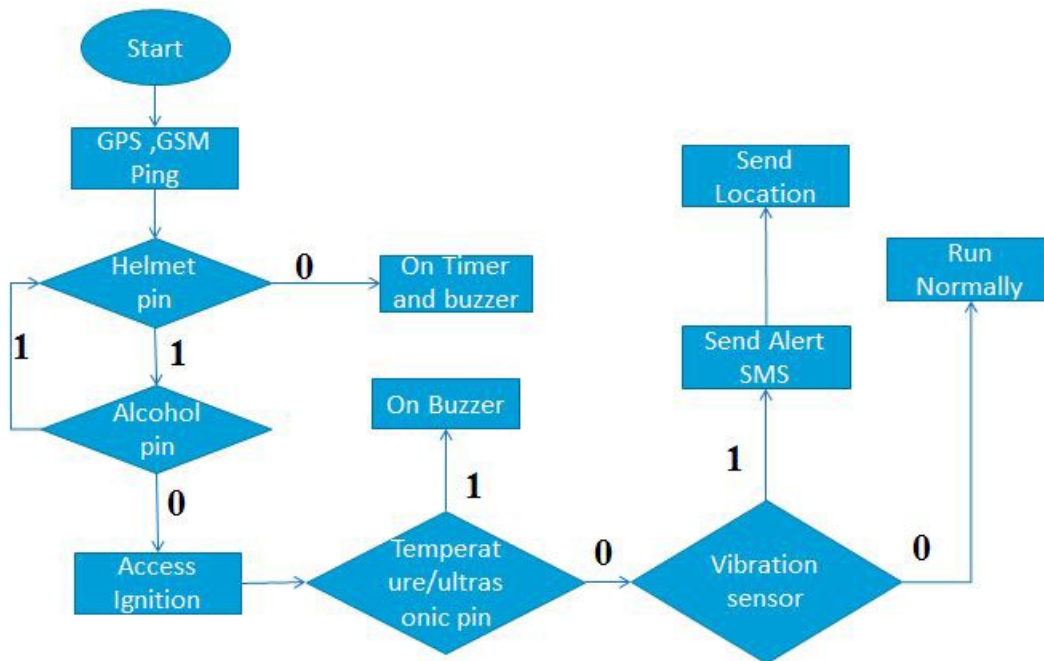

Figure: Flow chart of accident detection and prevention system

OK from the initialising step the system starts the timer and asks to wear the helmet. If the helmet pin is high i.e. the helmet is on, then it gives access to the ignition but if any interrupt occurs from alcohol sensor pin, the system rejects access to ignition system. If there is any obstacle before the threshold distance it gives a buzzer and displays distance on LCD which is measured using Proteus:

ultrasonic sensor. If there is any overheating due to revving the temperature sensor detects it and system indicates with a buzzer and display on LCD. For the detection part, the vibration sensor sends signal if any accident occurs and the system with the help of both GPS and GSM sends a message to the pre-programmed number.

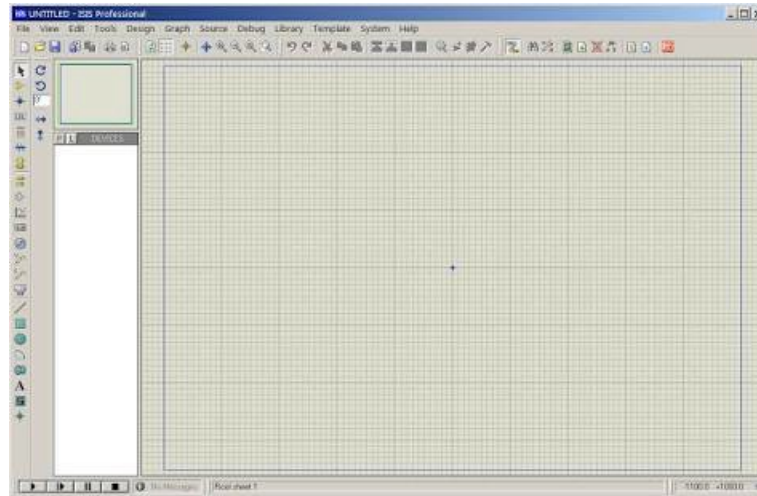

Figure: Proteus window

It is a software suite containing schematic, simulation as well as PCB designing. ISIS is the software used to draw schematics and simulate the circuits in real time. The simulation allows human access during run time, thus providing real time simulation.

ARES is used for PCB designing. It has the feature of viewing output in 3D view of the designed PCB along with components. The designer can also develop 2D drawings for the product.

## RESULTS:

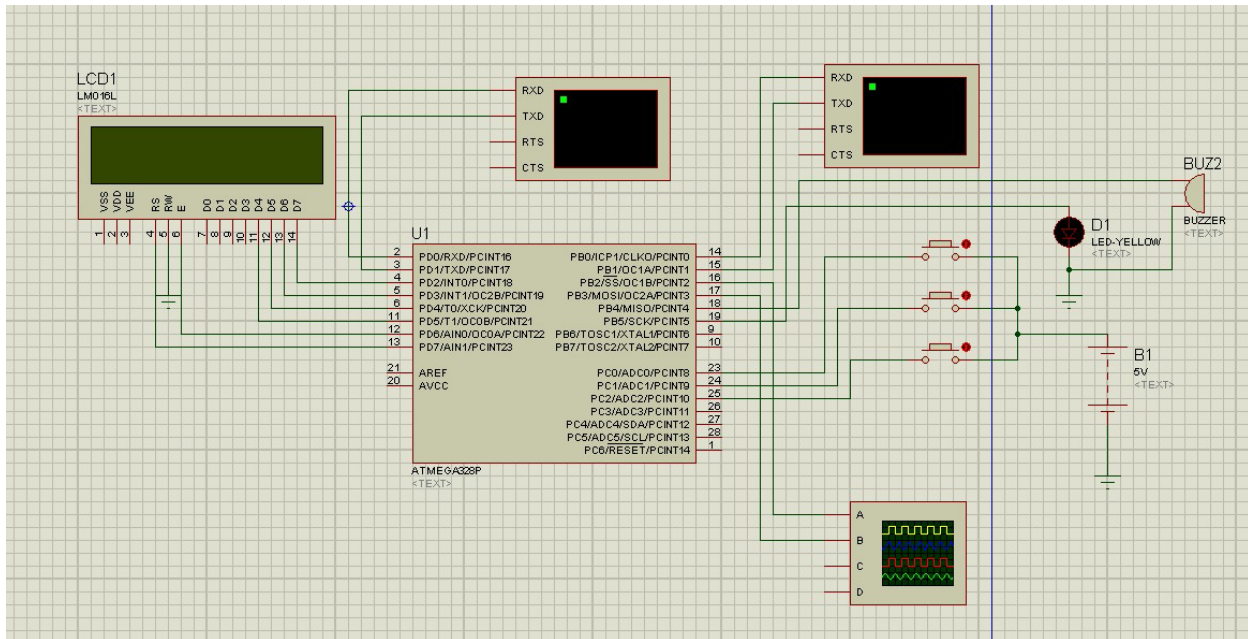
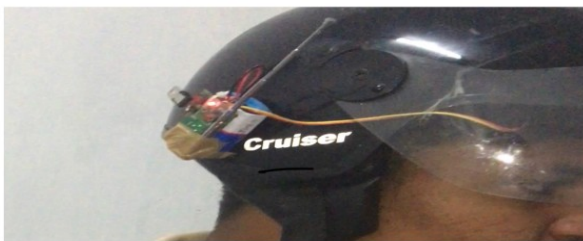

Figure: Circuit diagram of the system in proteus software

The proteus software contains all the required modules and components to form a circuit diagram and check its working. The sensors with analog data as their output are implemented as switches or buttons and given high or low as required to check output. The pins are connected according to the functions respectively and it is run to verify the output in software implemented circuit.

### Bike Ignition:

The access to ignition is obtained only when the helmet is on otherwise the system rejects access to the ignition and the rider can't start the bike which ensures the safety of the rider and prevents him from avoiding traffic rules. In the picture you can see the ignition light in ON condition and display on LCD when the helmet is on.



## Sensing Alcohol:

The safety of the driver is ensured with this feature in the system. The rider will not be given access to the ignition if any alcohol content is detected. This feature offers to avoid accidents occurring due to drunk driving



Figure: Display of alcohol sensing

## CONCLUSION:

Alcoholic detection that is Alcohol consumption is verified at starting process of the vehicle, if driver is drunk then the vehicle doesn't allow the driver to start the vehicle. If alcohol content is sensed in driver's breath while the vehicle is on drive the vehicle is automatically parked on to the left end of the road. If the driver is drowsy, an eye blink sensor implemented using IR sensor is used to sense the blink count and is compared with normal eye blink count and

upon abnormal blink movement, the speed of the vehicle is controlled automatically to park the vehicle to left end of the road. Immediate tracking of accidents: If any accident occurs then a piezoelectric sensor detects it and short message service along with location will be sent to predefined numbers. Pulse rate sensors are used to constantly monitor the driver's pulse rate and if driver's pulse is found to have abnormal rate then automatically park the vehicle to the left end of the road and





intimate through short message service using GSM along with the latitude and longitude location by using GPS

## **REFERENCES:**

- [1] Ueno H., Kanda, M. and Tsukino, M. "Development of Drowsiness Detection System", IEEE Vehicle Navigation and Information Systems Conference Proceedings,(1994), ppA13,15-20.
- [2] Sean Enright, Electronics Engineering Student, 506-6503611, May 26-2011, Alcohol Gas Detector "Breathalyzer"..
- [3] Chethana Gosal,"Automatic Student Tracking and Attendance Analysis System",IJIT, May 2016.Vol 2 Issue 3.
- [4] Weirwille, W.W. (1994). "Overview of Research on Driver Drowsiness Definition and Driver Drowsiness Detection," 14th International Technical Conference on Enhanced Safety of Vehicles, pp23-26.
- [5] Chethana Gosal,"Beagle Bone Black Based Security Robot",International Journal of Engineering Trends and Applications(IJETA), May 2016,Volume number 3 Issue 3.