

Optimization Of Materials By Performing Coupled Field Thermal , Structural & Fluid Analysis By Using Cfd On Radial Flow Micro Gas Turbine

,^[1]Dr. Ashok Kumar Vootla, ^[2]Pathri. Rajashakar

Associate professor, Dept. Mechanical engineering mother Theresa College of engg & tech. Peddapalli, , india

Dept of Mechanical engineering mother Theresa College of engg & tech. Peddapalli, , india
E-Mail: ashoko.vootla9@gmail.com , patrishekar@gmail.com

Abstract: A turbine blade is the person aspect which makes up the turbine phase of a gas turbine. The blades are answerable for extracting strength from the high temperature, high strain gas produced with the aid of the combustor. The turbine blades are frequently the restricting factor of gas turbines. To survive in this difficult environment, turbine blades regularly use distinctive materials like notable alloys and lots of exceptional methods of cooling, which includes inner air channels, boundary layer cooling, and thermal barrier coatings. In this mission, a turbine blade is designed and modeled in 3-D modeling software program CREO. The design is changed with the aid of changing the base of the blade to boom the cooling efficiency. Since the design of faster equipment is complicated, and efficiency is immediately associated with cloth performance, material selection is of top significance. In this project, materials are considered for turbine blade titanium alloy and nickel alloy. Optimization is achieved by using varying the materials Titanium alloy and Super Alloy by using acting coupled discipline evaluation (thermal+structural) at the turbine blade for each the designs.

Keywords: micro gas turbine , static analysis, thermal analysis , CREO parametric, ANSYS.

1. INTRODUCTION

The contemporary fashion towards miniaturization, portability and extra in popular ubiquitous intelligence, has brought about the improvement of a extensive variety of recent products including laptops, cellular telephones, PDAs, and so on. However, the electricity requirements of such systems have acquired a lot less attention: normally,

traditional battery-operated digital systems are used. Nevertheless, the electricity density of most gasoline

types remains 100 instances extra than that of the most performing batteries, which makes the usage of a gasoline-primarily based micro power unit thrilling. Such energy devices can be based on a huge range of running concepts, starting from fuel cells and thermo-electric powered gadgets, to combustion engines and gasoline generators. While gas cells are anticipated to provide the highest performance, micro fuel mills are anticipated to offer the very best power density.

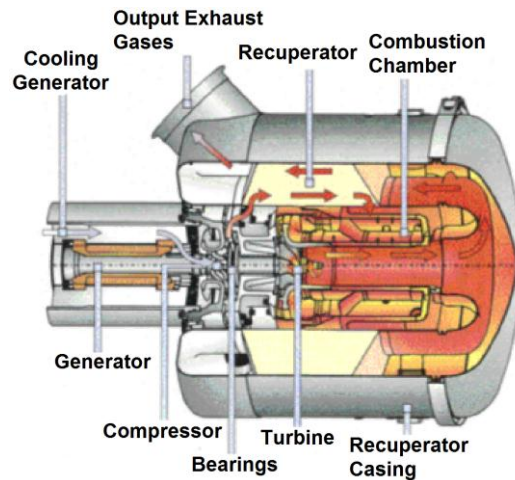

Fig: micro gas turbine

Gas turbines are among the most advanced systems as they combine intense situations in phrases of rotational speed with multiplied gas temperatures (up to 2100 K for army engines). Miniaturisation of this kind of gadget poses amazing technical problems as it results in extremely excessive rotational speeds (e.G. 106 rpm). Moreover scaling down the device unfavourably influences the waft and combustion method. Fabricating such gadgets calls for new substances to be explored (along with Si₃N₄ and SiC) and also requires three-dimensional micro manufacturing processes.

The micro gas turbine evolved by way of the Belgian PowerMEMS undertaking has a rotor diameter of 20 mm and could produce a strength output of approximately one thousand W. The device essentially consists of a compressor, regenerator, combustion chamber, turbine and electrical generator.

USES OF MICRO GAS TURBINES

Micro Gas Turbines may be used for numerous functions. MGTs most normally are used for strength era process, wherein the strength generated by a MGT is used to force a generator which generates strength and then this excessive frequency strength is transformed into usable 50/60Hz power using a rectifier and inverter meeting. Recently, MGTs have discovered there makes use of in vicinity of dispensed energy supply. MGTs are getting used to strength vehicles also. The businesses like GM, Toyota, Ford, Daimler Benz, and many others. Have invested a whole lot inside the research concerning using MGT in cars, however due to certain components, they by no means commercialized any of the automobiles. But nonetheless, researches are being finished to use the identical for powering motors. In this subject, a number of the hybrid automobiles have also come inside the image which makes use of the gas generators as considered one of its supply.

LITERATURE REVEIW

Micro turbine is one of the important additives in a micro gas turbine engine. Micro gasoline turbine engine is a promising approach to provide excessive-density power supply for micro systems. A micro gas turbine engine consists of a radial influx turbine, a centrifugal compressor and a combustor. This thesis specifically offers with the layout elements of a micro turbine. Various journals has been published on designing of diverse styles of micro generators. Exhaustive study has been carried out on these papers and the primary factors were highlighted here. In the paper —Design, fabrication and characterization of an air-driven micro turbine devicel by means of X. C. Shan, and Qide Zhang,

INTRODUCTION TO CAD

Computer-aided design (CAD) is using laptop structures (or workstations) to aid within the advent, change, analysis, or optimization of a layout. CAD software is used to increase the productiveness of the clothier, improve the great of layout, improve communications via documentation, and to create a database for production. CAD output is frequently within the form of digital documents for print,

machining, or other manufacturing operations. The term CADD (for Computer Aided Design and Drafting) is also used.

INTRODUCTION TO CREO

Pro/ENGINEER Wildfire is the equal old in 3-d product layout, presenting employer-main productiveness equipment that sell outstanding practices in design on the identical time as making sure compliance together with your agency and business enterprise requirements. Integrated Pro/ENGINEER CAD/CAM/CAE answers can help you format quicker than ever, even as maximizing innovation and extraordinary to in the end create great merchandise.

Customer necessities might also additionally alternate and time pressures may additionally continue to mount, but your product layout desires remain the same - irrespective of your challenge's scope, you need the powerful, smooth-to-use, much less costly answer that Pro/ENGINEER provides.

PRESENT MODEL

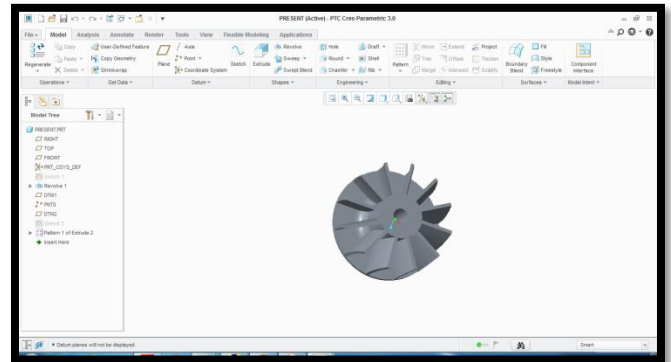

MODIFIED MODEL

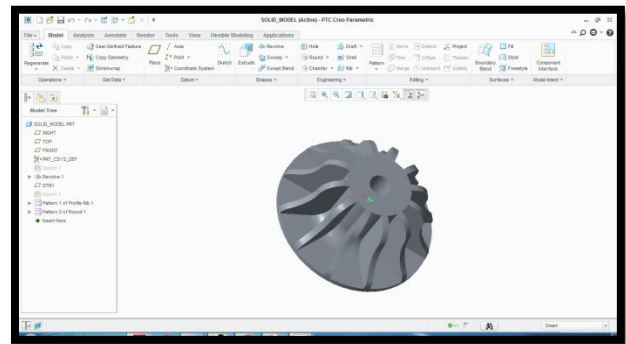

INTRODUCTION TO FEA

Finite element evaluation is a technique of solving, normally approximately, certain problems in

engineering and science. It is used specially for troubles for which no precise solution, expressible in a few mathematical shape, is available. As such, it is a numerical in preference to an analytical technique. Methods of this type are wanted due to the fact analytical strategies cannot cope with the real, complicated troubles which can be met with in engineering. For instance, engineering electricity of substances or the mathematical principle of elasticity may be used to calculate analytically the stresses and lines in a bent beam, but neither will be very successful in locating out what's going on in a part of a car suspension device for the duration of cornering.

INTRODUCTION

ANSYS is wellknown-reason finite detail evaluation (FEA) software bundle. Finite Element Analysis is a numerical method of deconstructing a complicated system into very small pieces (of person-exact length) called factors. The software implements equations that govern the behaviour of these factors and solves all of them; creating a comprehensive clarification of ways the machine acts as a whole. These outcomes then can be offered in tabulated, or graphical forms. This kind of analysis is typically used for the layout and optimization of a machine some distance too complex to analyze by hand. Systems that may match into this category are too complicated due to their geometry, scale, or governing equations.

CFD ANALYSIS OF MICRO GASTURBINE

PRESENT MODEL

INLET VELOCITY - 300 m/s

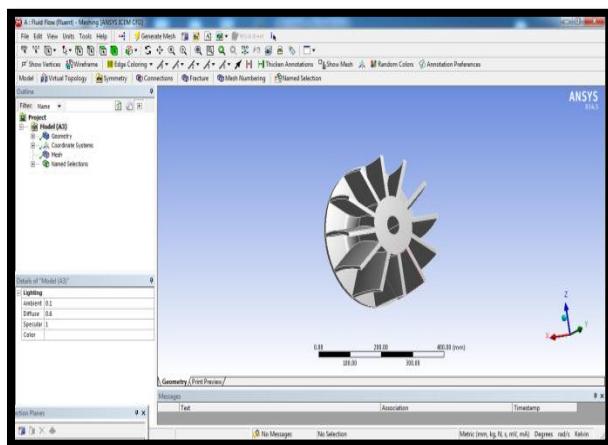

Select mesh on left side part tree → right click → generate mesh →

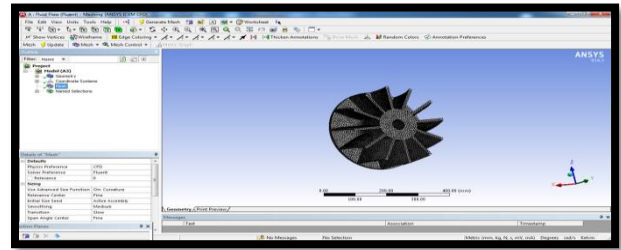

SPECIFYING BOUNDARIES FOR INLET AND OUTLET

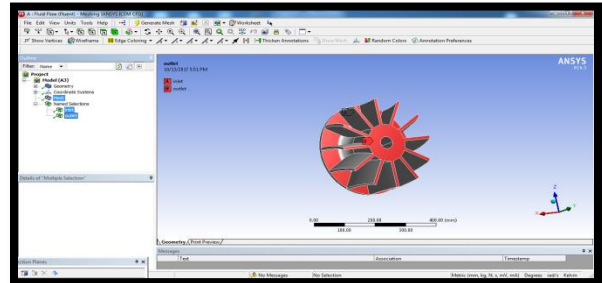

PRESSURE

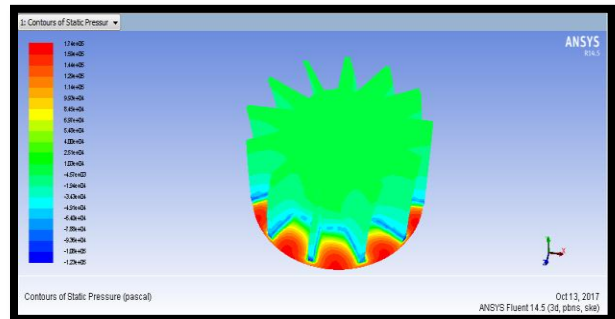

VELOCITY

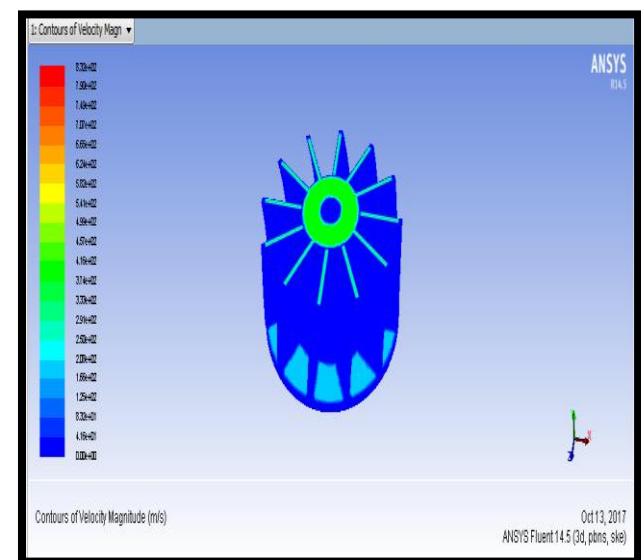

TEMPERATURE

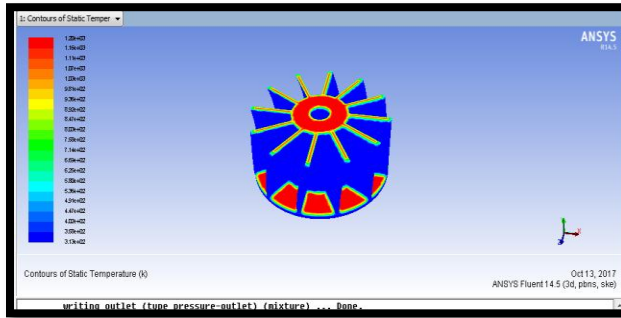

HEAT TRANSFER COEFFICIENT

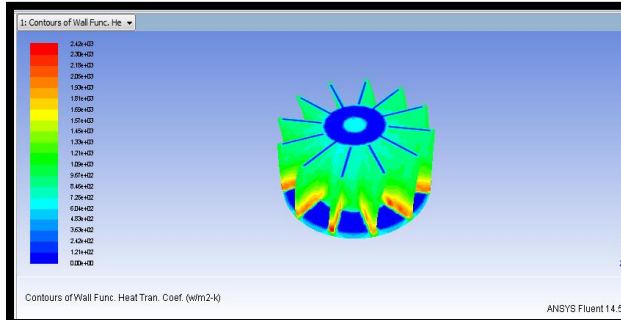

MASS FLOW RATE

Mass Flow Rate	(kg/s)
inlet	1.5792334
interior-__msbr	-0.80381191
outlet	-1.5832905
wall-__msbr	0
Net	-0.0040570498

HEAT TRANSFER RATE

Total Heat Transfer Rate	(w)
inlet	7420428
outlet	-7051347
wall-__msbr	-462223.94
Net	-93142.938

MODIFEID MODEL

INLET VELOCITY - 300 m/s

IMPORTED MODEL

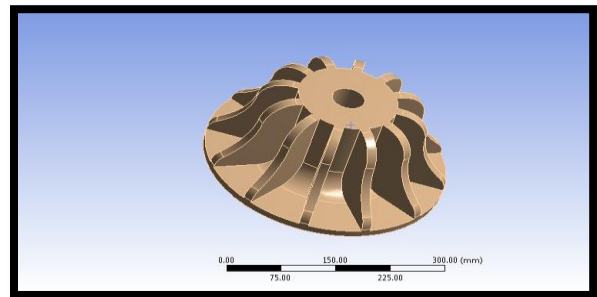

MESHED MODEL

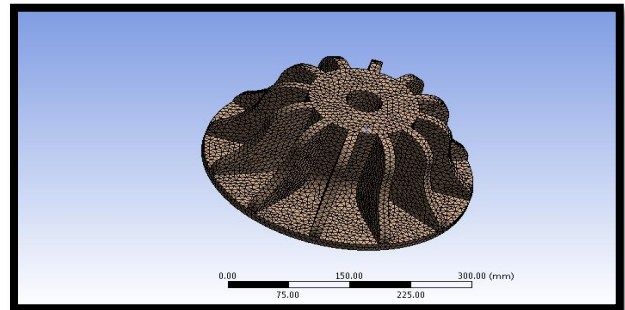

PRESSURE

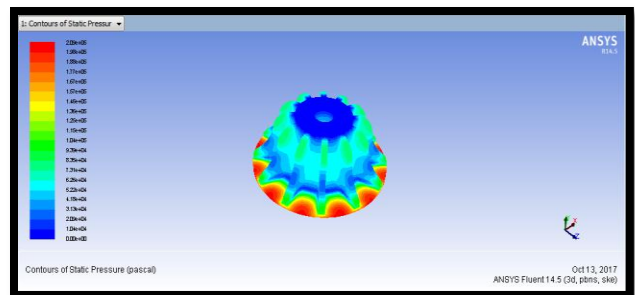

VELOCITY

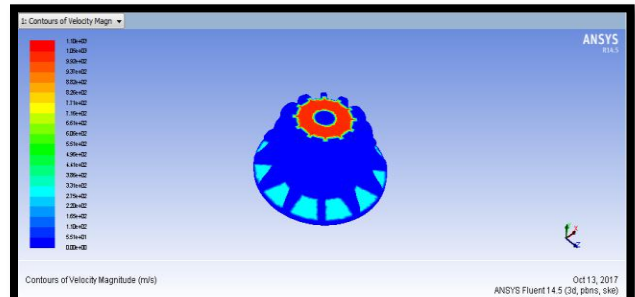

TEMPERATURE

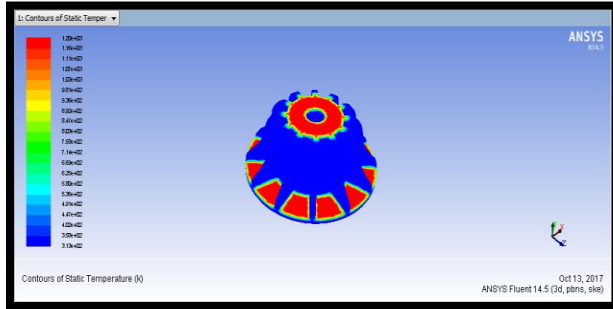

HEAT TRANSFER COEFFICIENT

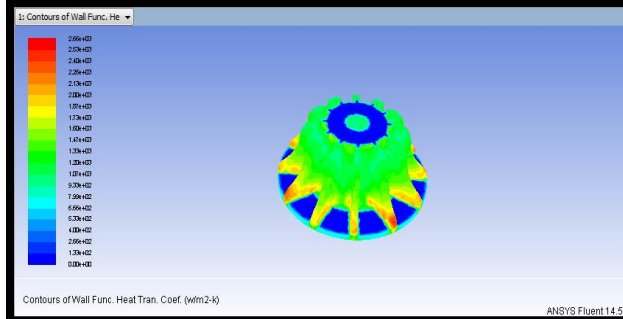

MASS FLOW RATE

Mass Flow Rate	(kg/s)
inlet	2.2241423
interior-___msbr	4.5505581
outlet	-2.2261696
wall-___msbr	0
Net	-0.0020272732

HEAT TRANSFER RATE

Total Heat Transfer Rate	(w)
inlet	10450627
outlet	-10144244
wall-___msbr	-429627.28
Net	-123244.28

THERMAL ANALYSIS MICRO GAS TURBINE CASE 1 -PRESENT MODEL MATERIALS

CHROMIUM STEEL

Thermal conductivity= 60.5 w/m-k

TITANIUM ALLOY

Thermal conductivity=21.9 w/m-k

NICKEL ALLOY

Thermal conductivity=70.1 w/m-k

BOUNDARY CONDITIONS

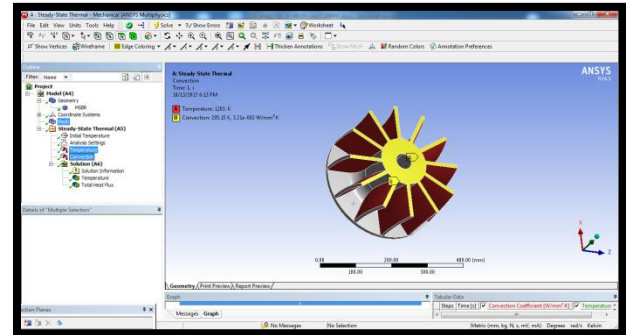

MATERIAL – CHROMIUM STEEL

TEMPERATURE

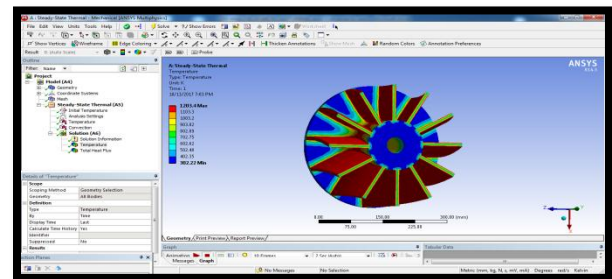

HEAT FLUX

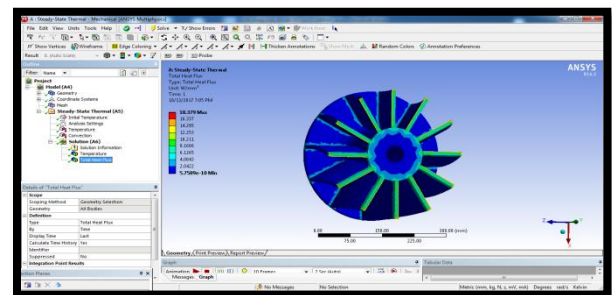

CASE 2 -MODIFIED MODEL

MATERIAL – CHROMIUM STEEL

TEMPERATURE

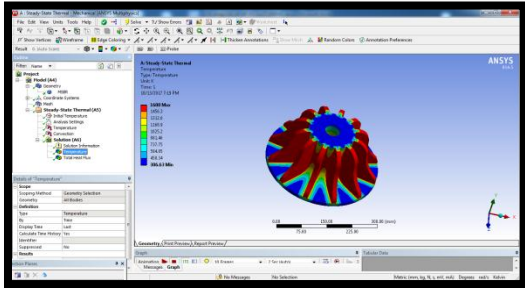

HEAT FLUX

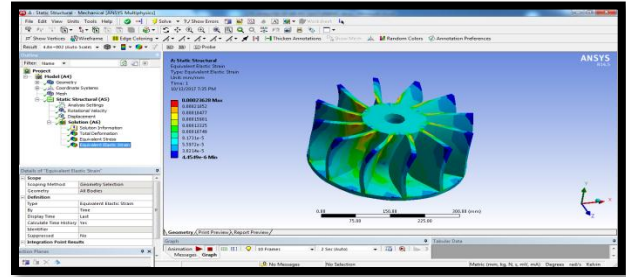

CASE 2-MODIFIED MODEL

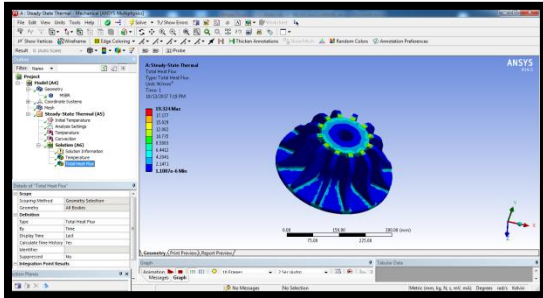

MATERIAL – CHROMIUM STEEL

Deformation

Stress

STATIC ANALYSIS

MATERIAL- CHROMIUM STEEL

Deformation

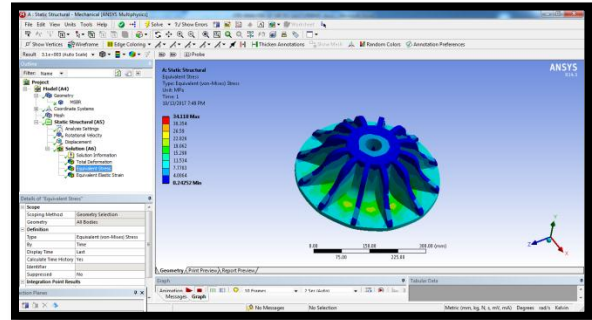

Strain

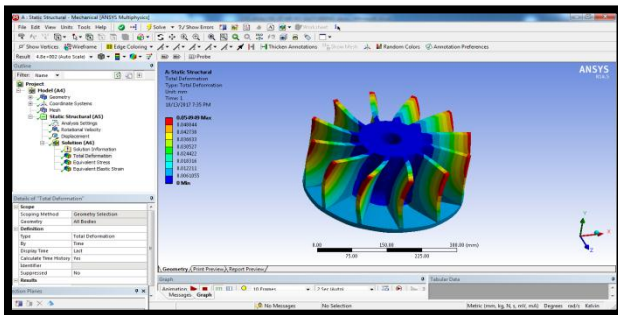

Stress

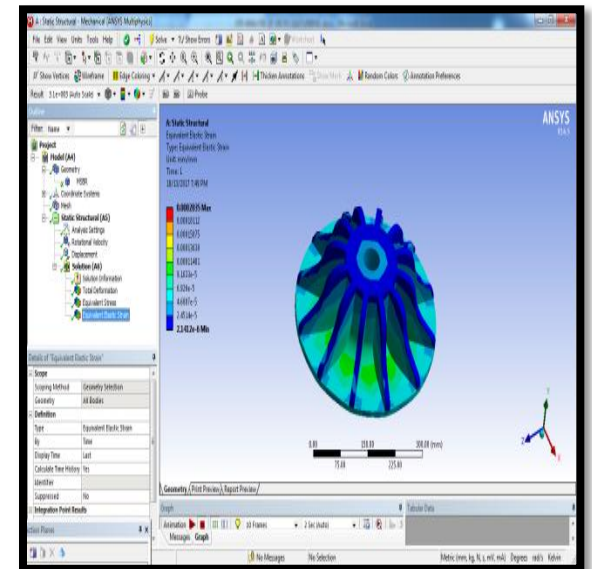

RESULTS TABLES

THERMAL ANALYSIS RESULTS

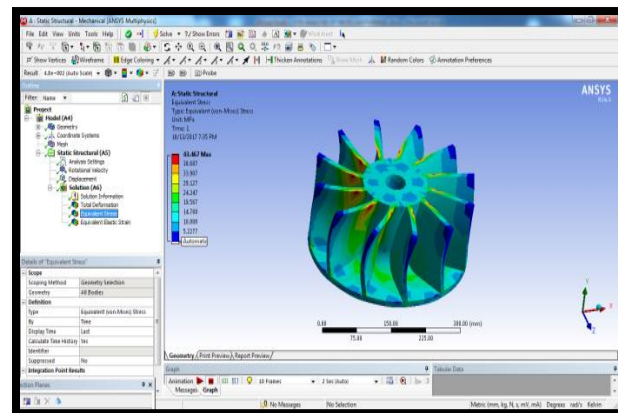

Strain

Geometry	Material	Temperature (K)		Heat flux
		MIN	MAX	
Present	Steel	302.22	1203.4	18.50
	Titanium	301.22	1203.6	8.966
	Nickel	305.23	1203.4	20.012
Modified	Steel	306.63	1203.5	19.324
	Titanium	173.54	1203.1	9.1194
	Nickel	308.12	1203.5	21.218

By observing CFD analysis results, the heat transfer value more for modified model compared to original model at velocity (540 m/s). To increasing blade velocity increases by pressure, velocity and heat transfer rates.

By observing Thermal analysis results, the heat flux value more for modified model with nickel alloy compared to other materials.

By observing static analysis results, the stress value less for modified model with titanium alloy compared to other materials.

static analysis results

Geometry	Material	Deformation (mm)	Stress (n/mm ²)	Strain
Present	Steel	0.054949	43.467	0.00023628
	Titanium	0.066426	25.629	0.0002849
	Nickel	0.065704	49.326	0.00028375
Modified	Steel	0.010477	34118	0.0002035
	Titanium	0.011804	18.684	0.000238
	Nickel	0.012666	39.117	0.00024479

So we can conclude that ,the modified model is better.

REFERENCES

- [1] O.E. Balje, Turbomachinery: A Guide to Design, Selection and Theory, Wileys, April 1981. [2] S.M. Yahya, Turbines, Compressors and Fans, Tata McGraw Hill Education Private Limited, New Delhi, 2005
- [3] A.H. Epstein, Micro-Heat Engines, Gas Turbines, and Rocket Engines - The MIT Microengine Project, American Institute of Aeronautics and Astronautics, 1997, pp. 1-12.
- [4] Available from [http:// www.Powermems. Com](http://www.Powermems.Com).
- [5] Available from <http://www.Planet-energy.Org>

CFD results

Geometry	Inlet velocity (m/s)	Pressure (Pa)	Velocity (m/s)	Temperature (K)	Heat transfer coefficient (w/m ² .k)	Mass flow rate(kg/s)	Heat transfer Rate(W)
Present	320	1.74e+05	8.32e+02	1.20e+03	2.42e+03	0.0040	93142
	420	1.76e+05	1.25e+03	1.20e+03	3.21e+03	0.0055	127789
	540	3.07e+05	1.67e+03	1.20e+03	3.93e+03	0.007137	160419
Modified	320	2.09e+05	1.10e+03	1.20e+03	2.66e+03	0.0020	123244
	420	4.10e+05	1.54e+03	1.20e+03	3.46e+03	0.0034	160926
	540	6.76e+05	1.98e+03	1.20e+03	4.17e+03	0.0038	175867

CONCLUSION

In this project, a micro gas turbine is designed and modeled in 3D modeling software CREO. The design is present and modified models by changing blade to increase the cooling efficiency and strength. Since the design of turbo machinery is complex, and efficiency is directly related to material performance, material selection is of prime importance.

In this project, three materials are considered for turbine blade chromium steel , titanium alloy and nickel alloy. Optimization is done by varying the materials by performing coupled field analysis (thermal+structural+fluid) on the micro gas turbine for both the designs.