

Design of High Performance Scan Register Insertion on Integer Arithmetic Cores

^[1]Vootla.Sridhar, ^[2]Dr. T.Srinivas

¹Research scholar(25617100), Dept of ECE, Shri jagadishprasad Jhabarmal Tibrewala University, Jhunjhunu, Rajasthan .&

Assistant professor, Dept. Electronic & Communication engineering
Mother Theresa College Of Engg & Tech. Peddapalli, , India

²professor, Dept. Electronic & Communication engineering . Peddapalli, , india
E-Mail: sridhar463@gmail.com¹, tspdpl@gmail.com²

ABSTRACT: Insertion of Scan flip-flop for testability invites in aiding design for overhead additional hardware thereby performing the deteriorating of the circuit. In this paper, we shall demonstrate a FPGA based implementation for Finite State Machines in the insertion of scan registers and data path pipelined circuits with no overhead or compromise in performance of the hardware. All our designs which as been proposed have been realized using a low-level design methodology relatively involving target FPGA family based instantiation primitive, coupled with their constrained placement on the fabric Xilinx FPGA. Implementation results clearly reveal the our proposed architectures in superiority comparison to equivalent circuits derived through modelling behavioural with respect to speed and area. Additionally, our proposed scan register rcircuit inserted with circuits designed without compare favourably for scan flip-flops. Coupled with this, lies the ease of an of the corresponding Hardware Description Language (HDL) automated generation and placement constraints and their portability among other FPGA families from advanced Xilinx.

1.INTRODUCTION

Design for testability (DFT) is an essential for enhancing the observability and controllability of a circuit. This often involves replacing the normal flip-flops (FFs) by scan FFs, which addition includes of a multiplexer at the normal the input FFs and the select line decides between the and the test normal mode or scan mode of operation. In the normal mode, the in accordance to the circuit operates functionality specified, while in the scan mode test , the series of FFs are converted into a shift register, through bit sequence which any desired input shifted-in serially through a dedicated scan in pin, or the of the circuit can be read out by entire state shifting out the FF dedicated scan out pin contents .Such circuit modifications invite additional hardware path delay owing to introduction of multiplexers and increase the critical. chain insertion Scan on FPGAs have been studied in [2] and [3], which resulted in previously resource overhead. However, for certain class of circuits, imposed through the limitations additional circuitry can be when such scan mitigated FF inserted circuits are deployed on modern FPGA families, which optimum logic support resources. In order to reap the of the advanced benefits FPGA architectures, it is not sufficient to enter a Register Transfer Level (RTL) behavioural or mode of Hardware Description Language (HDL) at the of the

FPGA design entry stage design flow. This is because heuristics used the logic synthesis by the CAD tools, often explore a narrow design space close to the architectural description given as input at the design entry level and unable to perform are often the requisite algebraic factoring, sub-expression sharing or apply the appropriate logic an efficient technology identities to realize mapped circuit. reason might A possible be that the CAD tools cater to a broader domain, and individual of applications attention to the of a well crafted design fine nuances may not always be feasible. Modern day Xilinx FPGAs Look-Up Tables (LUTs) support six input, with dual outputs. Often specific design, a LUT based implementation results in underutilization of the configured LUTs, where all the are not six inputs used. Additionally, the dual output functionality may also not get inferred at was feasible places where such realization, thereby resulting in more and delay hardware overhead. In this paper, we have targeted such configured, yet underutilized LUTs, to functionality into add extra design without the original disturbing architecture. The added feature is the Design for Testability (DFT), where the arrangement multiplexing necessary to realize scan FFs, has been accomplished by increasing the utilization ratio of the LUTs that realized the original design. This has resulted and carry chains in no additional hardware overhead and the speed

performance of the circuit inclusive of the DFT functionality matches to the using similar circuit realized principles of and constrained placement primitive instantiation but exclusive of the DFT functionality.

2. SLICE ARCHITECTURE OF XILINX VIRTEX-7 FPGA

A typical Configurable Logic Block (CLB) of our implementation platform, Virtex-7 FPGA, with each slice (called a “SLICEL” or “SLICEM”) contains 2 slices, comprising of four 6 input LUTs, eight flip-flops (FFs), three, and a carry chain wide function multiplexers [7]. Each LUT present in SLICEL can implement any arbitrary 6-input single output combinational logic, or two 5 (or less)-input (shared) functions, whereas the LUTs in can additionally implement SLICEM memory elements. The carry chain the fast carry represents propagation logic. Each FF can be controlled using the “set/reset”, “clock”, and “clock enable” signals. A typical Virtex-7 slice architecture, depicting only a subset of the above, has been shown in Fig. 1. The shaded multiplexers features mentioned inside the carry chain indicate that they cannot be instantiated or manually configured, only the CAD tool can configure them in accordance with the HDL.

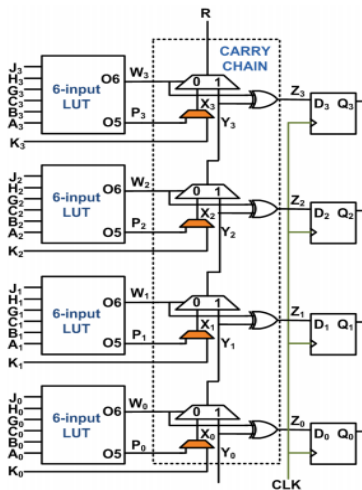

Fig. 1. A simplified Virtex-7 slice architecture.

Architecture of Proposed Designs

In this section, we shall present the detailed FPGA architectures of the arithmetic cores as well as their scan FF incorporated versions.

Loadable Bidirectional Resetable Counter Binary counter, which as a fundamental serves

component of many controlpath implementations, should the following desirable features of resettability, loadability, bidirectionality, possess count-enable, and detectability terminal count [8].

Loadable Bidirectional Resetable Counter Realized Through Primitive Instantiation and Constrained Placement:

A counter is a D-FF based Parallel-In Parallel-Out register and an incrementer/decrementer, as shown in Fig. 2. $D_i = Q_i \oplus (Q_{i-1} \cdot Q_{i-2} \dots Q_1 \cdot Q_0)$ for an incrementer and $D_i = Q_i \oplus (Q_{i-1} + Q_{i-2} + \dots + Q_1 + Q_0)$ for a decrementer if $i \geq 1$. $D_0 = Q_0$ for both incrementer and decrementer. The wide input AND and OR gate for incrementer and decrementer respectively, are realized using the carry chain. The 6-input LUT is configured as $O_i = (LD \cdot Q_i + LD \cdot EXT_i) \oplus U/D$, where the counter counts up if $U/D = 0$, counts down if $U/D = 1$, and loads external data if $LD = 1$.

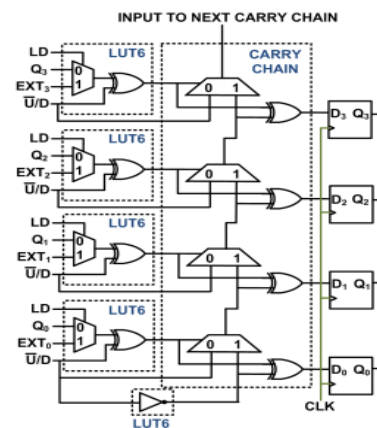

Fig. 2. Original architecture for loadable bidirectional counter.

The terminal count is detected by the carry output of the most significant carry chain. Each multiplexer of the carry chain computes AND or OR operation as $R_i = O_i \cdot U/D + O_i \cdot R_{i-1}$ where R_{i-1} is the previous AND-ed or OR-ed output. This recurrence relation bears resemblance to (1) making it amenable for carry chain implementation. If $U/D = 0$, $R_i = O_i \cdot R_{i-1}$ representing AND functionality, and if $U/D = 1$, $R_i = O_i \cdot 1 + O_i \cdot R_{i-1} = O_i + R_{i-1}$, thereby representing OR functionality. $R_i = U/D$ for $i = 0$. The XOR gates of the carry chain compute the next state of the counter, $D_i = O_i \oplus R_{i-1}$. The architecture utilizes four out of six inputs per LUT, and a single output instead of the dual outputs of the configured LUTs. Thus, an n -bit counter occupies $n + 4 + 1$ slices, $(n + 1)$ LUTs and n FFs.

3. SCAN FF INCORPORATED COUNTER DESIGN REALIZED THROUGH PRIMITIVE INSTANTIATION AND CONSTRAINED PLACEMENT:

In this architecture, the counter operates in two different modes: the *normal* mode and the *scan* mode. In the *normal* mode of operation, the as per the specified counter operates functionality. In the *test* mode, the into the carry chain through a multiplexing arrangement as shown in Fig. 3, and the carry chain fabric is configured to connect all the FFs in a serial-input serial-output (SISO) mode serial data is fed via the LUTs, without disturbing the parallel read-out capability of the counter. This feature serves as an advantage to test other their inputs from the counter. In fact, we present a relevant sub-circuits deriving case study of such a design paradigm in Section V-A. In the architecture depicted in Fig. 3, the $O6$ and $O5$ outputs of LUTs compute the following functions: $O6i = TD[(LD \cdot Qi + LD \cdot EXTi) \oplus U/D]$ and $O5i = TD \cdot Qi + TD \cdot U/D$. Each multiplexer of the carry chain computes $Ri = O6i \cdot O5i + O6i \cdot Ri-1$, where $R0 = TD \cdot U/D + TD \cdot SD$. This recurrence relation also bears resemblance to (1) making it amenable for carry chain implementation. Thus, our proposed n -bit counter with scan FFs occupies $n \cdot 4 + 1$ slices, $(n + 1)$ LUTs and n FFs.

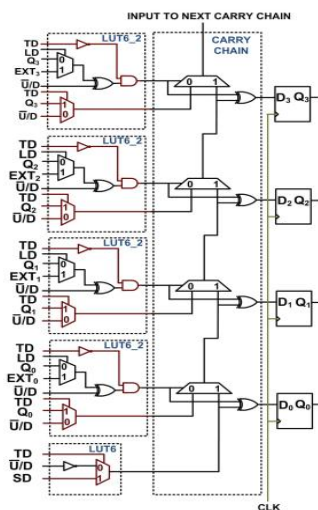

Fig. 3. Proposed architecture for scan FF inserted loadable bidirectional counter. (The added functionality of the LUTs is shown in brown.)

4. Universal Shift Register

Universal Shift Register is a useful data path circuit which has bidirectional shifting and parallel load capabilities.

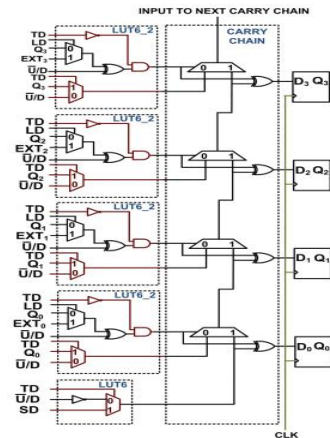

Fig. 3. Proposed architecture for scan FF inserted loadable bidirectional counter. (The added functionality of the LUTs is shown in brown.)

Universal Shift Register Realized Through Primitive Instantiation and Constrained Placement:

The architecture of the universal shift register is shown in Fig. 4. Two inputs $S1$ and $S0$ decide the operation mode of the registers, and the combinational logic deciding the functionality can be realized using a 4:1 multiplexer with the options of bidirectional shifting, parallel with directly controlling loading and retaining of previous data as shown in Table I. Additionally, the circuit is also resettable the “reset” input of the FFs. In this architecture, all the six inputs of the LUT are utilized. Thus, an n -bit circuit occupies $n \cdot 4$ slices, n LUTs and n FFs.

TABLE I
 FUNCTION TABLE OF UNIVERSAL SHIFT REGISTER

Mode Control Inputs $S_1 S_0$	Register Operation
0 0	Shift left
0 1	Parallel load
1 0	Freeze data
1 1	Shift right

Scan FF Incorporated Universal Shift Register Realized Through Primitive Instantiation and Constrained Placement:

The scan register insertion in Universal Shift Register circuit can be achieved through re-ordering of certain inputs and changing the priority of different functionalities over one another. This for incorporating additional control inputs, thereby avoiding additional hardware overhead, as the

original design had already used up all the six inputs of the LUTs. The function corresponding table is depicted in Table II. The “Freeze data” functionality is achieved by connecting has been done to create room an active low signal NC to the clock– enable pin of the D–FF, whereas the input to and *test* mode of operation for converting the LUT for the left–shift functionality FFs into a scan chain, can be shared. Thus, an n –bit circuit occupies $n + 4$ slices, n LUTs

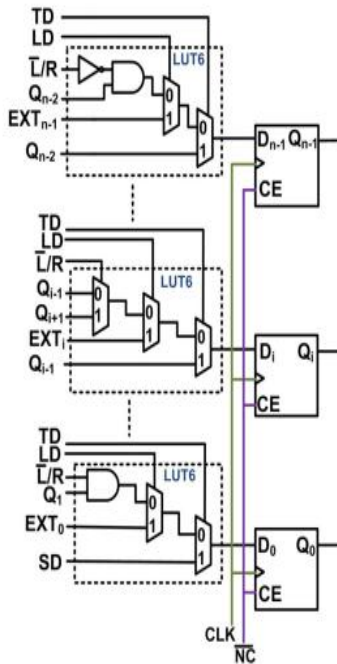

Fig. 5. Proposed architecture for scan FF inserted universal shift register and n FFs.

TABLE II
 FUNCTION TABLE OF SCAN FF INSERTED UNIVERSAL SHIFT REGISTER

Mode Control Inputs NC LD \bar{L}/R	Register Operation
0 X X	Freeze data
1 1 X	Parallel load
1 0 0	Shift left
1 0 1	Shift right

Case Study: A Pipelined Two’s Complement Adder–Subtractor Tree

Adder–subtractor tree is a useful sub–circuit that often finds applications in the parallel implementation of arithmetic distributed based FIR Filters, matrix multiplication circuits or pipelined binary tree multipliers [9]. Each ADD/SUB block shown in Fig. 6 can configured as a be independently two’s complement adder or subtractor, mode as they have independent select lines. Each of the blocks can

perform a 24–bit two’s complement addition/subtraction, with a of ADD/SUB blocks. The been re–designed by circuit has total of five stages also inserting scan FFs at the site of the pipeline registers with no hardware and performance deterioration overhead. The slice of a pipelined adder/subtractor tree without the scan configuration FFs have been shown in Fig. 7. The sum bit can be computed by EX–ORing the LUT and carry chain multiplexer output as

$$S_i = A_i \oplus (B_i \oplus M) \oplus C_i.$$

The carry output of each multiplexer stage can be computed as:

$$C_{i+1} = A_i(B_i \oplus M) + (A_i \oplus (B_i \oplus M))C_i$$

$$= A_i(A_i(B_i \oplus M) + (A_i \oplus (B_i \oplus M))C_i)$$

$$= A_i(A_i(B_i \oplus M) + (A_i \oplus (B_i \oplus M))C_i) \oplus (A_i \oplus (B_i \oplus M))C_i$$

$$= A_i(A_i \oplus B_i \oplus M) + (A_i \oplus (B_i \oplus M))C_i \dots (2)$$

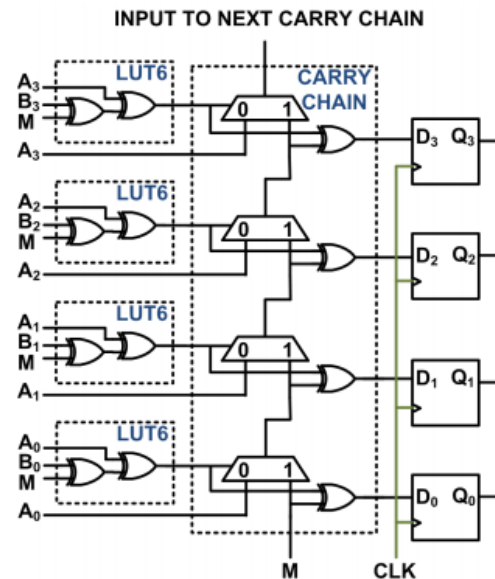

Fig. 7. Original pipelined adder subtractor design.

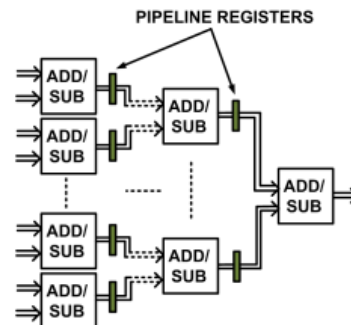

Fig. 6. Block diagram of pipelined adder subtractor tree.

Equation (2) bears resemblance to (1) making it suitable for carry chain implementation. $C_i = M$ for $i = 0$. The scan FF inserted pipelined adder-subtractor tree has been shown in Fig. 8. In this circuit, we configure the LUTs in the dual output mode where $O6i = (A_i \oplus B_i \oplus M)TD$ and $O5i = A_i \cdot TD + Q_i \cdot TD$. The carry output of each multiplexer stage is computed as $C_{i+1} = O6i \cdot O5i + O6i \cdot C_i$, which bears resemblance to (1), making it suitable for carry chain implementation. $C_0 = M$ for normal mode of operation ($TD = 0$), and $C_0 = SD$ for test/scan mode of operation ($TD = 1$). Since normal mode and scan mode are two non-overlapping operations, the mode input pin receives input during test mode scan-in data of operation. Each of the ADD/SUB blocks have dedicated mode control or serial data input. This allows certain ADD/SUB blocks in the adder tree to operate in the test mode, where any desired bit sequence may be the registers scanned into, which in turn may act as inputs to verify the functionality block operating of another ADD/SUB in the normal mode, that receives its inputs from those registers.

CONCLUSION

We have presented high performance, automated FPGA designs of integer cores arithmetic with scan FFs, following the principle of instantiation primitive and constrained placement. ideally suits The methodology circuits where the configured logic elements are underutilized, or the nature of the circuit in itself permits certain design specific changes such as reshuffling of inputs priority encoding for insertion of scan FFs with no hardware overhead. option settings for any synthesis or optimization goal and effort for the behavioural No amount of changes designs can match up to our proposed architecture, both in terms of speed and area

REFERENCES

- [1] M. L. Bushnell and V. D. Agrawal, *Essentials of Electronic Testing for Digital, Memory and Mixed-Signal VLSI Circuits*. Kluwer Academic Publishers, 2000.
- [2] A. Tiwari and K. A. Tomko, "Scan-chain Based Watch-points for Efficient Run-Time Debugging and Verification of FPGA Designs," in *ASP-DAC*, 2003, pp. 705–711.
- [3] T. Wheeler, P. Graham, B. Nelson, and B. Hutchings, "Using Design-Level Scan to Improve FPGA Design Observability and Controllability for Functional Verification," in *Field-Programmable Logic and Applications*, ser. LNCS, vol. 2147, 2001, pp. 483–492.

- [4] A. K. Verma, P. Brisk, and J. P. Jenne, "Challenges in Automatic Optimization of Arithmetic Circuits," in *19th IEEE International Symposium on Computer Arithmetic*, June 2009, pp. 213–218.
- [5] A. Ehliar, "Optimizing Xilinx designs through primitive instantiation," in *Proceedings of the 7th FPGAworld Conference*, 2010, pp. 20–27.
- [6] A. Palchoudhuri and R. S. Chakraborty, *High Performance Integer Arithmetic Circuit Design on FPGA: Architecture, Implementation and Design Automation*. Springer India, 2015.
- [7] Xilinx Inc., "7 Series FPGAs Configurable Logic Block, UG474 (v1.5)", Aug. 6 2013. [Online]. Available: http://www.xilinx.com/support/documentation/user_guides/ug474_7Series_CLB.pdf
- [8] M. R. Stan, A. F. Tenca, and M. D. Ercegovac, "Long and Fast Up/Down Counters," *IEEE Transactions on Computers*, vol. 47, no. 7, pp. 722–735, July 1998.
- [9] U. Meyer-Baese, "Digital Signal Processing with Field Programmable Gate Arrays", 3rd ed. Springer Series on Signals and Communication Technology, 2007.