

Design and Analysis of Heavy Vehicle Chassis by Using Materials Steel & S-Glass

G murthi Prasad Rao

Assistant Professor, Department of Mechanical Engineering, visvesvaraya college of engineering and technology
gmprasad12345@gmail.com

ABSTRACT:

The automobile is divided into two parts body and chassis. The chassis is basic structure of a vehicle. It contains all the engine parts and power systems but the frame is the main portion of chassis which do not contain any other assemblies like engine parts. Its principle function is to safely carry the maximum load for all designed operating conditions. Composite material is a material composed of two or more distinct phases and having bulk properties significantly different from those of any of the constituents. Different types of composite material are available and one of it is Polymer matrix composite. It has the benefits of high tensile strength, high stiffness and good corrosion resistance etc. At present this polymer matrix composite materials are used in aerospace, automobile industries due to it high strength to low weight ratio. In the present work, the dimensions of an existing heavy vehicle chassis of a TATA 1109 EX2 vehicle is taken for modeling and analysis. The vehicle frame is initially modeled by considering „C“ cross section in SOLID WORKS 2014 then it is imported to ANSYS 13.0. The analysis is done with two different composite materials namely Steel and S-glass/Epoxy subjected to the same pressure as that of a steel frame. The design constraints are stresses and deformations. The results are then compared to finalize the best among all the four frames.

I. INTRODUCTION:

Automotive chassis is a French word that was initially used to represent the basic structure. It is a skeletal frame on which various mechanical parts like engine, tires, axle assemblies, brakes, steering etc. are bolted.

It gives strength and stability to the vehicle under different conditions. Automobile chassis is usually made of light sheet metal or composite plastics. It provides strength needed for supporting vehicular components and payload placed upon it. Automobile chassis or automobile chassis helps keep an automobile rigid, stiff and unbending. It ensures low levels of noise, vibrations and harshness throughout the automobile. Automobile chassis without the wheels and other engine parts is called frame. Automobile frames provide strength and flexibility to the automobile. The backbone of any automobile, it is the supporting frame to which the body of an engine, axle assemblies are affixed. Tie bars that are essential parts of automotive frames are fasteners that bind different auto parts together. Automotive frames are basically manufactured from steel. Aluminum is another raw material that has increasingly become popular for manufacturing these auto frames. In an automobile, front frame is a set of metal parts that forms the framework which also supports the front wheels.

Automotive chassis is a skeletal frame on which various mechanical parts like engine, tires, axle assemblies, brakes, steering etc. are bolted. The chassis is considered to be the most significant component of an automobile. It is the most crucial element that gives strength and stability to the vehicle under different conditions. Automobile chassis provide strength and flexibility to the automobile. The backbone of any automobile, it is the supporting frame to which the body of an engine, axle assemblies are affixed. Tie bars, that are essential parts of automotive frames, are fasteners that bind different auto parts together.

Problem Identification

Weight reduction is now the main issue in automobile industries. At the same time as the weight of the vehicle increases the cost also increases which becomes a major issue while purchasing an automobile. For example if we take frame of TATA 1109 EX 2 heavy vehicle frame. It is manufactured with Structural

FRP Composites

FRP composites are defined as the materials that consist of fibers embedded in a resin matrix. The aim of combining fibers and resins that are different in nature is to take advantage of the distinctive material features of either component to result in an engineered material with desired overall composite action for specific applications. Such a composite is considered to be a discontinuous fiber or short fiber composite if its properties vary with fiber length.

Particular types of fibers applications:

Load-bearing capacity, level of exposure, wear resistance, temperature and frequency ranges, fire and water resistance and costs are some of the important issues that need to be thoroughly considered. Various advantages of composite materials are its high specific stiffness and high specific strength. These properties are generally used in structural application such as aerospace and sporting goods.

Glass Fibers:

The most common reinforcement for the polymer matrix composites is a glass fiber. Most of the fibers are based on silica (SiO₂), with addition of oxides of Ca, B, Na, Fe, and Al. The E-glass is designated for electrical use and the S-glass for high strength.

The C-glass is for high corrosion resistance, and it is uncommon for civil engineering application of the three fibers, the E-glass is the most common reinforcement material used in civil structures. It is produced from lime-alumina borosilicate which can be easily obtained from abundance of raw materials like sand. The glass fiber strength and modulus can degrade with increasing temperature. Although the glass material creeps under a sustained load, it can be designed to perform satisfactorily. The fiber itself is regarded as an isotropic material and has a lower thermal expansion coefficient than that of steel.

Steel

Stainless steels contain a minimum of 11% chromium, often combined with nickel, to resist corrosion. Some stainless steels, such as the ferrite stainless steels are magnetic, while others, such as the austenitic, are nonmagnetic.

Composition of steel

Table – I

Steel. Steel structures exposed to air and water, such as bridges are susceptible to corrosion. In conditions of repeated stress and more temperatures it can suffer fatigue and cracks. These are the main problems of steel and these are compensated by inducing composite materials.

Constituent	Weight Percentage
Si	1.8
C	0.565
Mn	0.7
P	0.045
S	0.045
Impurities	Traces

Mechanical Properties of Steel

Table – II

Properties	STEEL
Young's modulus (GPa)	190-210
Shear modulus, G_{12} (GPa)	75-80
Major Poisson's ratio, ν_{12}	0.30
Minor Poisson's ratio, ν_{21}	0.27
Shear modulus, S (GPa)	80

S-glass:

Fibers have a magnesium aluminosilicate composition, which demonstrates high strength and used in application where very high tensile strength required.

Typical Properties of E-Glass and S-Glass

Table – III

Typical Properties	S-Glass
Density (g/cm^3)	1.6
Young's Modulus (GPa)	87
Tensile Strength (GPa)	2.53
Tensile Elongation (%)	2.9

II. INTRODUCTION TO CHASSIS

Automotive chassis is a skeletal frame on which various mechanical parts like engine, tires, axle assemblies, brakes, steering etc. are bolted. The chassis is considered to be the most significant component of an automobile. Automobile frames provide strength and flexibility to the automobile. The backbone of any automobile, it is the supporting frame to which the body of an engine, axle assemblies are affixed. Tie bars, that are essential parts of automotive frames, are fasteners that bind different auto parts together.

Automotive frames are basically manufactured from steel. Aluminum is another raw material that has increasingly become popular for manufacturing these auto frames.

In an automobile, front frame is a set of metal parts that forms the framework which also supports the front wheels. It provides strength needed for supporting vehicular components and payload placed upon it.

Different types of automobile chassis:

Ladder Chassis:

Ladder chassis is considered to be one of the oldest forms of automotive chassis that is still used by most of the SUVs till today. As its name connotes, ladder chassis resembles a shape of a ladder having two longitudinal rails inter linked by several lateral and cross braces. The truck frame allows different types of truck beds or enclosures to be attached to the frame. For larger trucks, the frames are simple, rugged, and of channel iron construction. The side rails are parallel to each other at standardized widths to permit the mounting of stock transmissions, transfer cases, rear axles, and other similar components. Trucks that are to be used as prime movers have an additional reinforcement of the side rails and rear cross members to compensate for the added towing stresses.

Backbone Chassis:

Backbone chassis has a rectangular tube like backbone, usually made up of glass fibre that is used for joining front and rear axle together. This type of automotive chassis or automobile chassis is strong and powerful enough to provide support smaller sports car. Backbone chassis is easy to make and cost effective.

A backbone chassis like this can actually be slightly stiffer than a space frame of the same weight. However, because the chassis has to fit within the confines of the centre of the body, it can only be made so stiff. As such, it tends to lend itself better to small or medium sized vehicles, as large, powerful cars do not necessarily have enough of a proportional increase in the room available for the central backbone to allow it to be scaled up to cope with the increased loads.

Monocoque Chassis:

Monocoque Chassis is a one-piece structure that prescribes the overall shape of a vehicle. This type

of automotive chassis is manufactured by welding floor pan and other pieces together. Since monocoque chassis is cost effective and suitable for robotised production, most of the vehicles today make use of steel plated monocoque chassis.

VEHICLE CHASSIS DESIGN

The automotive chassis provides the strength necessary to support the vehicular components and the payload placed upon it. The suspension system contains the springs, the shock absorbers, and other components that allow the vehicle to pass over uneven terrain without an excessive amount of shock reaching the passengers or the cargo. The steering mechanism is an integral portion of the chassis, as it provides the operator with a means of controlling the direction of travel. The tyres grip the road surface to provide good traction that enables the vehicle to accelerate, brake, and make turns without skidding. Working in conjunction with the suspension, the tyres absorb most of the shocks caused by road irregularities.

EARLIER CHASSIS DESIGNS

The chassis is the "skeleton" of the truck - providing the structural strength, and the mounting points for other components. In this section, we will be looking at the various types of chassis design that have been used in truck.

LADDER-FRAME CHASSIS

Many of the principles and techniques used to build cars evolved from the manufacture of horse-drawn vehicles, and early chassis design reflects this. The image on the left shows a 1920's Dodge minus its body, and is a typical example of pre-war chassis design: Two long rails running the length of the vehicle, with the engine mounted between them and the axles suspended underneath. The body would then be mounted on top of the chassis. This kind of chassis is generally known as a *ladder-frame* design, as the members that run between the two rails resemble the rungs of a ladder when viewed from above.

SPACE-FRAME CHASSIS

As we mentioned, the problem with a ladder-frame chassis is that, although strong, it isn't very stiff. The suspension and steering systems on cars are designed on the basis that they are mounted to a solid object, so having a chassis that "squirms" under load prevents the suspension doing its job as intended. Obviously, this is a major issue when you are designing a racing vehicle, and so it is here that we shall look. If you were to try and make a ladder-frame chassis stiffer, your natural starting point would be to add bracing to prevent twist.

SUBFRAMES

In most instances, a car will have all its major components mounted directly to the chassis. However, in some cases, a subframe will be used. This is an individual "mini-chassis" that carries certain components (such as the engine and drivetrain, or the rear suspension) as an assembly, and is then attached to the main chassis or bodyshell. The best known use of subframes is in a mini (left), where a front subframe carries the engine, gearbox and front suspension, and a rear subframe carries the rear suspension, but many cars use a simple subframe as the mounting point for the rear suspension. In most cases, a subframe design is used in conjunction with a monocoque design - There's no reason why you couldn't use a subframe with a ladder-frame or space-frame chassis, though there would be no real advantage.

CHASSIS MATERIALS

Traditionally, the most common material for manufacturing vehicle chassis has been steel, in various forms. Over time, other materials have come into use, the majority of which have been covered here.

Steel

Machinery to manipulate steel is easy to get. People who know how to work with steel are easy to get. Steel is easy - and it's also cheap. This is the main reason why 99% of the cars you find are made from

steel, although the fact that it's actually a very useful material plays no small part. Steel is by no means a "does the job" or "poor man's" option - the material has many attributes that render it perfect for vehicle chassis manufacturing. First, yes, the cost and availability (of both the material and what you need to process it) are a major advantage for commercial production, but the physical properties are also highly beneficial.

Aluminium

Aluminium is probably the material that springs to mind when you think about lighter alternatives to steel, and with good reason - the density of aluminium is in the region of 35% of that of steel. However, the first thing we should cover is the fact that when we talk about aluminium as a structural material, we are almost always talking about an *alloy* of aluminium - with an addition of magnesium, zinc etc depending upon the intended end use of the metal. The reason for this is that raw aluminium has too low a yield strength for structural use in a vehicle chassis.

Titanium

Titanium has an association with space tech, and is regarded by many people as an "ultimate" material. It has a density roughly half that of steel, and also a little over half the stiffness value. It's a similar situation with regards to ultimate and yield strengths. Understandably, this means that the methods used to build with titanium are similar to those for building with aluminium: Tubing should be larger in diameter than for steel, to compensate for the lower inherent stiffness, though this does not need to be as pronounced as with aluminium. Again, when we talk about using titanium to build structures, we are referring to alloys rather than raw metal, though straight titanium is not as weak as straight aluminium.

Fiberglass

Raw plastics do not have anywhere near enough stiffness to be used for structural components in cars. If strands of glass are added to the mixture, though, their properties improve remarkably. This gives you a Glass Fibre Reinforced Plastic (GFRP or GRP), most commonly referred to as fibreglass.

Like a plastic, fibreglass can be moulded to practically any shape. Although nowhere near as

stiff or strong as steel, the ability to create practically any shape allows you to compensate for this. A bodyshell or tub may be created in a single piece, with no seams that could be weak points, and made with variable thickness - Extremely thick near high-load areas such as suspension mountings, and very thin in unstressed panels, all in the same unit. It is this infinite variability across a structure that allows a properly designed fibreglass construction to be both stiff and light.

Carbon Fibre

Carbon fibre is very similar to fibreglass, only with carbon strands rather than glass strands as the reinforcing medium - it's correct description would be Carbon Fibre Reinforced Plastic (CFRP/CRP), though almost everyone refers to it as simply "carbon fibre". It is a lot like fibreglass, only despite a density that is almost exactly the same; it can have the strength of an aluminium alloy and the stiffness of steel.

The key to this is that, unlike fibreglass, where the strands are pretty much random, carbon fibre uses a woven matt of fibres - this is what gives it its distinctive appearance. Getting the full strength and stiffness advantages requires maintaining the correct alignment of this weave, and so carbon fibre structures cannot be compression moulded, they have to be laid up in layers. This requires time and skill, and is probably the biggest factor in the high cost of using carbon fibre.

CHASSIS JOINING

No matter what design of chassis is used for a vehicle, or what material is chosen to build it, as some point joints are going to have to be made

Seam Welding

Welding is where two metal components are joined by melting them into each other where they meet. The heat to do this can be generated through either burning gas or electrical resistance; Gas welding uses acetylene, and pure oxygen is added to produce a flame hot enough to melt metal (air is only 21% oxygen). For metals with a melting point below the 1500°C (roughly) of steel, other gases may be a viable option for welding. An additional rod of fillet metal, with a coating of flux, is dipped into the weld as it is made to create a stronger joint, and the flux helps prevent getting oxygen in the molten metal, which would weaken the structure.

Spot Welding

Spot welding is a form of electrical welding used to fasten two sheets together. Two stubby rods clamp the sheets, and pass the electric current through that point to join them. Although not as strong as seam welding, due to less weld area and load forces not being equally distributed across the joint, it's strong *enough* for most purposes, and is fast and easy to robotise. This makes it very suitable for production lines, and is the technique used for producing monocoque bodysHELLS in car factories worldwide. It is also effective at reducing the chances of distortion due to heating the surrounding panel compared to traditional welding.

Stitch Welding

Stitch welding is very similar to seam welding, only short welds are spaced along the join rather than a continuous run being used. Other than that, it's pretty much the same. Using stitch welding can help avoid distortion, as less heat is put into the material. This technique is not used often in chassis manufacture: In most instances, you might as well just go all the way and seam weld. However, if a chassis is going to be galvanized to prevent corrosion, stitch welding helps: Galvanizing is a chemical process that dips components in a very hot bath to coat them. Seam welds can sometimes trap air between parts, which expand with the heat and crack the weld. Stitch welding leaves a gap that can allow the gases to escape.

Bolts & Threaded Fasteners

Bolts, nuts and screws have the advantage that they can be removed non-destructively and re-used, so that an assembly may be dismantled and rebuilt with no new material or parts (unless the fittings stretch in use etc, but we'll ignore that one). This also means that separate components can be loosened and realigned as necessary, or replaced if damaged. Also, dissimilar materials may be joined together (subject to them having a reaction to each other, of course).

Rivets

A rivet secures joints in the same way as using a bolt, only the clamping force is generated by crushing the ends of a short rod that runs through the hole, rather than tightening the fastener down. Traditional rivets, as originally used for heavy-duty construction like bridges and ships, were literally forced into shape

after being heated up to soften them. There is absolutely no problem with this technique - it's still used - but it is quite labor intensive.

III. ANALYSIS OF CHASSIS

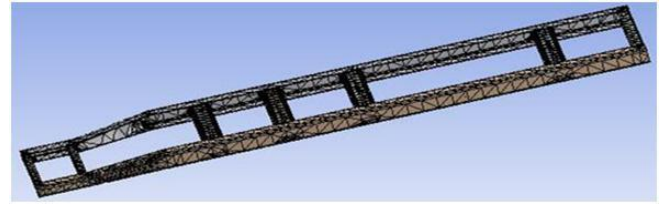

Fig 1: Isometric View of Frame after Meshing

Fixed Supports

The fixed supports for the frame are placed at the wheel positions. The total number of supports is four. The first support is placed at 470 mm from the front end the second support is placed at 1680 mm from the rear side. The other two supports are placed at same positions on the other side.

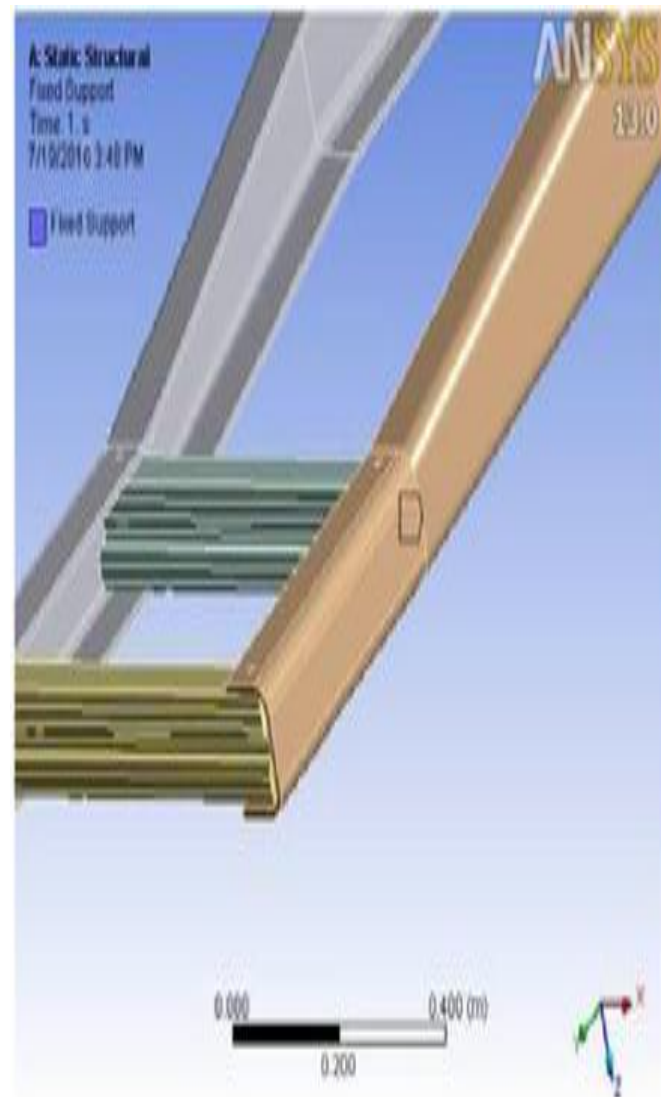

Fig 2: Fixed supports at Front wheel position

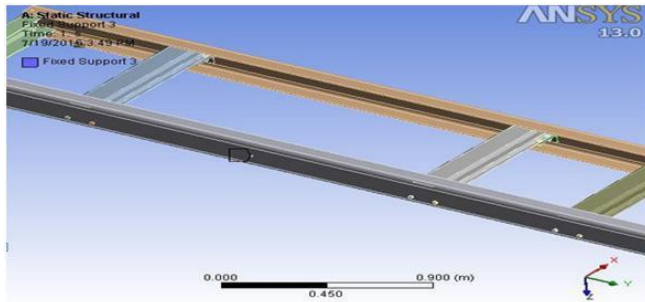

Fig3: Fixed supports at Rear wheel position

Application of Loads

The load application is the major part in the analysis of a component. There may be different types of loads like Uniformly Distributed Load, Uniformly Varying Load and Point Load. The present frame carries the UDL throughout its length.

From the vehicle specifications FAW = 7950 Kg
 RAW = 3950 Kg

Total GVW = 11900 Kg

As the frame supports the bodt by its two side frames

The load on each side member = 11900/2 = 5950 kg

The total area on which the UDL is placed = 5620 × 100 = 562000 mm²

Total pressure applied = Total load /Total area
 = 5950/562000 = 0.01058 kg/mm²
 = 0.1038 N/mm² = 0.1038 MPa

MPa

The pressure is applied on the two side members of the frame as shown in Fig.

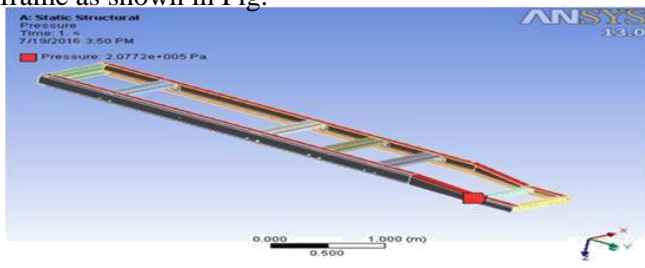

Fig 4: Area on which Pressure is applied

Analysis by Using Structural Steel

It is steel construction material, a profile, formed with a specific shape or cross section and certain standards of chemical composition and mechanical properties. Structural steel shape, size, composition, strength, storage, etc., is regulated in most industrialized countries. Composition 0.565% C, 1.8% Si, 0.7% Mn, 0.045% P and 0.045% S.

Mass of Frame

The mass of an object is a fundamental property of the object, a numerical measure of its inertia, a

fundamental measure of the amount of matter in the object. Mathematical equation for mass is Mass = Volume × Density

We know, Density of steel = 7850kg/m³

Volume of frame = 4.9104×10⁻² m³

Total mass of frame = 7850 × 0.049104 = 385.46 kg

Stresses developed in chassis

It is a physical quantity that expresses the internal forces that neighboring particles of a continuous material exert on each other. For example, when a solid vertical bar is supporting a weight, each particle in the bar pulls on the particles immediately above and below it. These macroscopic forces are actually the average of a very large number of intermolecular forces and collisions between the particles in those molecules. There are many types of stresses developed in a component. The frame is analyzed by considering Equivalent stress and normal stress.

Normal stress

The component of stress which is perpendicular to the plane on which the force is applied is called Norma stress. This stress is also called as principle stress. Its value should not exceed the yield strength of the material. In some of the situations design is considered to be safe if its value is less than the yield strength of the material. The normal stress distribution in the frame for structural steel is as shown in Figure. It can be inferred that

Maximum normal stress = 3359 Mpa

Minimum normal stress = - 6317 Mpa

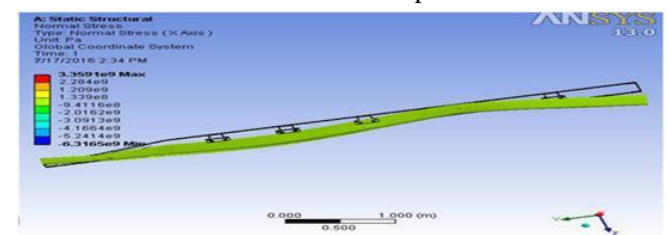

Fig 5: Normal Stress Distribution in Frame (Structural Steel)

Equivalent stress

When an elastic body is subjected to loads in its three dimensions, the stresses will get developed along the principle axis of the bodystresses. These stresses should not exceed the yield stress of the material. VonMises postulated that, even though none of the principal stresses exceeds the yield stress of the material, it is possible for yielding of the same from the combination of stresses. Von Mises stress is considered to be a safe

haven for design engineers. Using this information an engineer can say his design will fail, if the maximum value of Von Mises stress induced in the material is more than strength of the material. It works well for most of the cases, especially when the material is ductile in nature. The Equivalent stress distribution in the frame for structural steel is as shown in Figure it can be inferred that Maximum Equivalent stress = 17686 MPa (Approx.) Minimum Equivalent stress = 0 MP

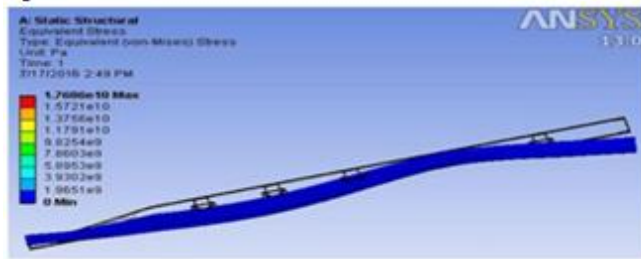

Fig 6: Equivalent Stress Distribution in Frame (Structural Steel)

Deformation

When an object is subjected to loading its shape may be changed temporarily or permanently due to applied force. This change in shape is called deformation. If the object deforms permanently it is called plastic deformation or failure. If it deforms temporarily it is called elastic deformation. While analyzing a frame the frame should deform elastically within the maximum loading limit so that the design is safe. The values of deformation obtained in ANSYS 13.0 for structural steel are as shown in Figure Maximum deformation = 5.7 mm (Approx.)

Minimum deformation = 0 mm

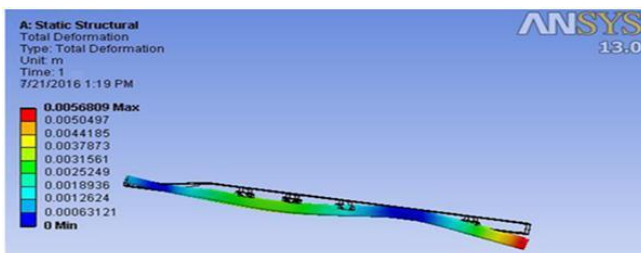

Fig 7: Total deformation in frame (Structural steel)

Analysis by Using S-glass/ Epoxy

The manufacturing process for glass fibers suitable for reinforcement uses large furnaces to gradually melt the silica sand, limestone, kaolin clay, fluorspar, colemanite, dolomite and other minerals to liquid form. Then it is extruded through bushings, which are bundles of very small orifices. These filaments are then sized (coated) with a chemical solution. The individual filaments are now bundled together in large numbers to provide a roving.

The diameter of the filaments, as well as the number of filaments in the roving determines its weight. Common uses of S-glass include high performance aircraft (gliders), boats, automobiles, baths, hot tubs, septic tanks, water tanks, roofing, pipes, cladding, casts, surfboards and external door skins. Composition: 64% SiO₂- 24% Al₂O₃- 10% MgO

Mass of Frame

Mathematical equation for mass is Mass = Volume × Density

We know Density of S-glass/ epoxy = 1600 kg/m³

Volume of frame = 4.9104 × 10⁻² m³

Total mass of frame = 1600 × 0.049104 = 79kg (Approx.)

Stresses developed in Frame

The two types of stresses are considered for analyzing the frame and their respective stress distributions are as shown in Fig.

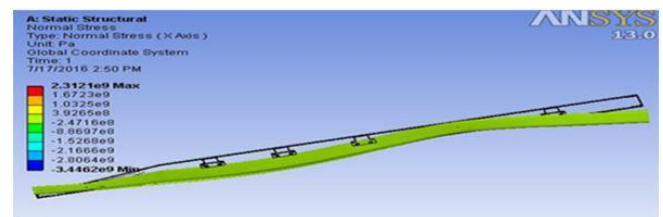

Fig 8: Normal Stress Distribution in Frame (S-glass/ Epoxy)

Max.Normal stress = 2312MPa(Approx.)

Min. normal stress = -3446 MPa (Approx.)

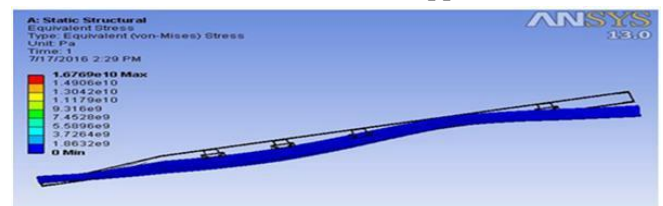

Fig 9: Equivalent Stress Distribution in Frame (S-glass/ Epoxy)

Maximum Equivalent stress = 16769MPa,

Minimum Equivalent stress = 0MPa

Deformation

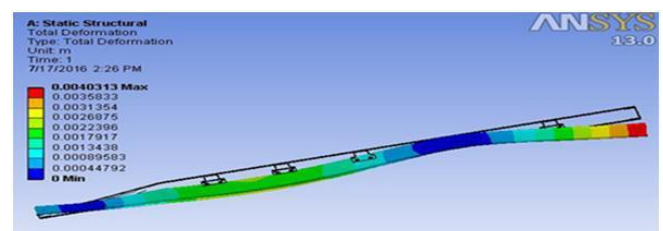

Fig 10: Total Deformation in Frame (S-glass/ Epoxy)

Epoxy)

Maximum deformation = 4.03 mm,
 Minimum deformation = 0 mm

IV. RESULTS:

From the above analysis using different materials, the results obtained for stresses and deformations are Comparison of Results

Material	Mass (Kg)	Max. Normal Stress (MPa)	Max. Eq Stress (MPa)	Max. Deformation (mm)
Structural Steel	385	3359	17686	5.68
S-glass/Epoxy	79	2312	16769	4.03

Table-V

From the above table it can be inferred that S-glass/Epoxy is having the least values when compared to remaining three materials. For less mass the S-Glass/ Epoxy gives more strength. It can be explained by following calculations

For Structural Steel

Density = 7850 kg/m³
 Ultimate tensile strength = 900 MPa
 Strength to weight ratio = 900/7850 = 0.1146 MNm/kg

= 115Nm/g

(Approx.)

For S-glass/Epoxy

Density=1600kg/m³
 Ultimate tensile strength=600 MPa
 Strength to weight ratio =600/1600=0.375 MNm/kg =375Nm/g

(Approx.)

The results obtained are represented graphically as shown below.

Deformationin (mm)

Fig 11: Graphical Representation of Deformation

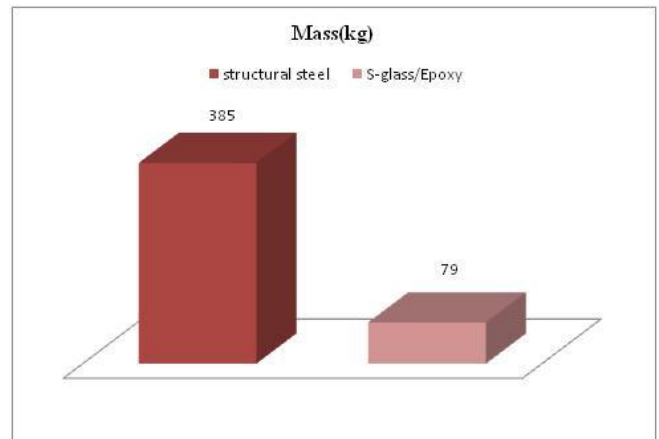

Fig 12: Graphical Representation of Mass

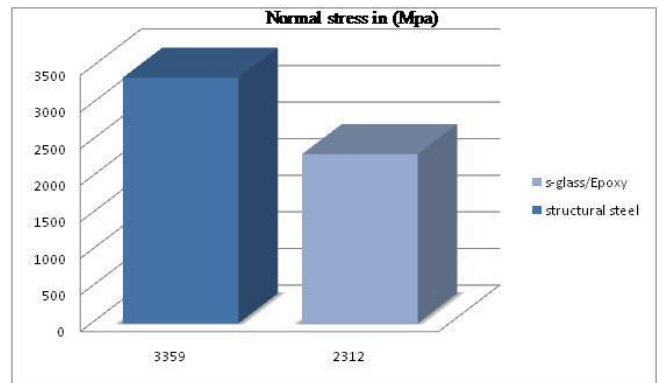

Fig 13: Graphical representation of Normal stress

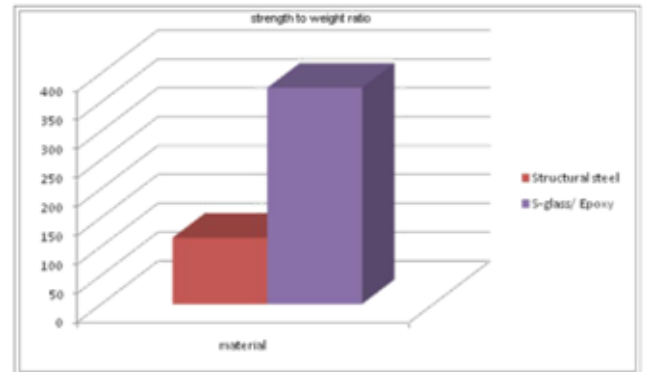
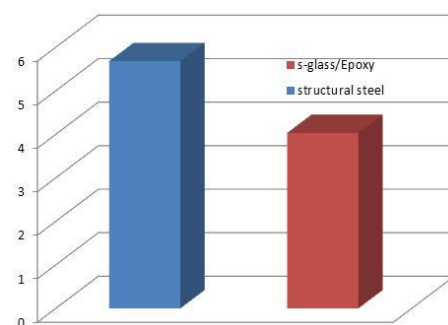

Fig 14: Graphical Representation of strength to weight ratio



V. CONCLUSION

Present used material for chassis is steel. We have considered polymeric composites like S-glass for chassis material. By employing a polymeric composite heavy vehicle chassis for the same load carrying capacity, there is a reduction in weight of 75% to 85%. Based on the results it was inferred that S-glass polymeric composite heavy vehicle chassis has superior strength, less deformation, less normal stress and less weight compared to steel. The most advantage is better to use S-glass as a material for frames of heavy vehicle chassis. The fuel consumption decreases for the vehicles.

SCOPE

There is a high scope for further research in chassis simulation to solve vibration, frequency response and mode shape analysis related problems. This chassis structure should be further analyzed and improved on the overall performance especially on structural dynamic behavior and quality auditing for better refinement. Based on these factors, the overall recommendation is to study the structural analysis and should be covered on the overall truck system and after that focus on the specific area such as chassis. This analysis will help to make full body refinement and improvement because it can be related to actual running condition.

REFERENCES

- [1] Ahid D. Nashif, David I. G. Jones and John P. Henderson, "Vibration Damping", John Wiley & Sons Publication, 1985, Newyork.
- [2] K. J. Buhariwala and J. S. Hansen, "Dynamics of Visco elastic Structures", AIAA Journal, Vol. 26, February 1988, pp 220-227.
- [3] J. M. Biggerstaff and J. B. Kosmatka, "Damping Performance of Cocured Composite Laminates with Embedded Visco elastic Layers", Journal of Composite Materials, 1998 .
- [4] C. T. Sun and Y. P. Lu, "Vibration Damping of Structural Elements", Prentince Hall PTR, New Jersey, 1995.