

Performance Improvement of External Inductor based Voltage Controlled DSTATCOM using Fuzzy Logic Controller

M.SANTHOSH, ASSNT.PROF,EEE DEPARTMENT
MOTHERTHERESSA COLLEGE OF ENGINEERING

Abstract— This project proposes a new algorithm to generate reference voltage for a distribution static compensator (DSTATCOM) operating in voltage-control mode. The proposed scheme exhibits several advantages compared to traditional voltage-controlled DSTATCOM where the reference voltage is arbitrarily taken. A distribution static compensator (DSTATCOM) is used for load voltage regulation and its performance mainly depends upon the feeder impedance and its nature (resistive, inductive, stiff, non-stiff). This project aims to provide a comprehensive study of design, operation, and flexible control of a DSTATCOM operating in voltage control mode. A detailed analysis of the voltage regulation capability of DSTATCOM under various feeder impedances is presented. Then, a standard design process to work out the value of external inductor is offered. A dynamic reference load voltage generation scheme is also developed which allows DSTATCOM to compensate load reactive power during normal operation, in addition to providing voltage support during disturbances. Simulation results are validating the effectiveness of the proposed scheme using Mat lab/Simulink software.

Index Terms— *Distribution Static Compensator (DSTATCOM), Current Control, Voltage Control, Power Factor, Power Quality, Fuzzy Logic Controller.*

I. INTRODUCTION

The fast growth and reputation of power electronics technology lead to wide use of industry loads which possess power quality (PQ) issues [1]. The power quality is primarily exaggerated due to current harmonics introduced by the nonlinear loads into the distribution network. The PQ issues featured with harmonic distortion, low power factor and phase disproportion produce astonishing turbulence in the function of electrical equipment [2]. Conventionally, static capacitors and passive filters have been employed to enhance PQ in distribution system. Nevertheless, these frequently have issues like fixed compensation, system parameters dependent performance and probable resonance with line reactance [3]. Owing to this the capability to even out the transmission systems and to enhance PQ in distribution systems is showed [6]. Distribution Static synchronous compensator (DSTATCOM) is prevalently acknowledged as a consistent reactive power controller substituting traditional VAR compensators, like the thyristor-switched

capacitor (TSC) and thyristor controlled reactor (TCR). This device endow with reactive power compensation, active power oscillation damping, flicker attenuation, voltage regulation [4].

DSTATCOM is a component of Flexible AC Transmission Systems (FACTS) family that is associated in shunt with the power system [5]. By controlling the magnitude of the DSTATCOM voltage, the reactive power interactions between the DSTATCOM and the transmission line control the quantity of shunt compensation in the power system [6-7]. The DSTATCOM is a power electronics device depends on the law of injection or absorption of reactive current at the point of common coupling (PCC) to the power network. The benefit of the DSTATCOM is that the compensating current does not depend on the voltage level of the PCC and thus the compensating current is not minimized as the voltage drops. The supplementary motive for choosing a DSTATCOM as an alternative of an SVC are on the whole superior operational features, faster performance, lesser size, cost minimization and the capability to give both active and reactive power, thereby providing flexible voltage control for power quality enhancement [8].

The load compensation using a DSTATCOM one of the device. The load compensation using a DSTATCOM one of the major considerations is the generation of the reference compensator currents. Power quality problems include high reactive power burden, harmonic currents and load unbalance [9]. Owing to the widely application of power converters in the industry products, power pollution has been serious problem in the distribution system. The power pollution due to large non-linear loads low power factor, low efficiency of power system, voltage distortion and losses in the transmission and distribution lines. In a DSTATCOM, generally, the DC capacitor voltage is regulated using a PI controller when various control algorithms are used for load compensation [10]. However, during load changes, there is considerable variation in DC capacitor voltage which might affect compensation. In this work, a fuzzy logic based supervisory method is proposed to improve transient performance of the DC link. Now a day there has been growing interest in applying fuzzy theory to controller design in many engineering fields. In recent years, fuzzy logic controllers have gained much attention

for various applications. The main advantage in use of FLCs is to allow designers to incorporate experimental knowledge in adjustment of controlling parameters. The mamdani type FLCs have been reported for the DSTATCOM but it requires large number of fuzzy sets. In authors have used fuzzy controller for control of power filter [11-13]. The fuzzy controller has very attractive features over conventional controllers. It is easy to be implemented in a large scale nonlinear dynamic system and not so sensitive to the system models, parameters and operation conditions. In particular human knowledge can be included in control rules with ease [14-15]. Therefore investigation of fuzzy theory application in power system control grows rapidly. In this paper fuzzy logic controller for distribution Static compensator is implemented.

II. DSTATCOM IN POWER DISTRIBUTION SYSTEM

Fig.1 shows power circuit diagram of the DSTATCOM topology connected in distribution system. L_s and R_s are source inductance and resistance, respectively. An external inductance, L_{ext} is included in series between load and source points. This inductor helps DSTATCOM to achieve load voltage regulation capability even in worst grid conditions, i.e., resistive or stiff grid. From IEEE-519 standard, point of common coupling (PCC) should be the point which inaccessible to both the utility and the customer for direct measurement [20]. Therefore, the PCC is the point where L_{ext} is connected to the source. The DSTATCOM is connected at the point where load and L_{ext} are connected. The DSTATCOM uses a three-phase four-wire VSI. A passive LC filter is connected in each phase to filter out high frequency switching components. Voltages across dc capacitors, V_{dc1} and V_{dc2} , are maintained at a reference value of V_{dcref} .

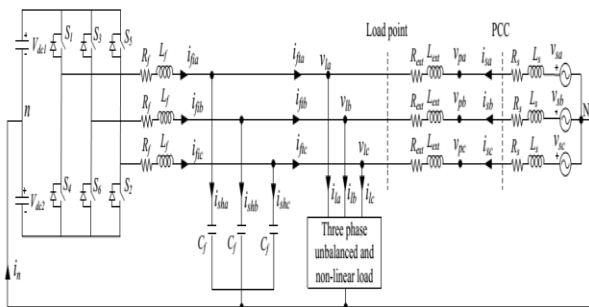

Fig.1. Three phase equivalent circuit of DSTATCOM topology in distribution system

III. EFFECT OF FEEDER IMPEDANCE ON VOLTAGE REGULATION

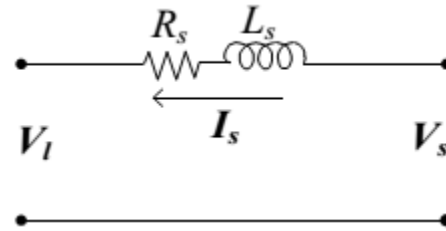

Fig.2. Equivalent source-load model without considering external inductor

To demonstrate the effect of feeder impedance on voltage regulation performance, an equivalent source-load model without considering external inductor is shown in Fig.2. The current in the circuit is given as

$$I_s = \frac{V_s - V_l}{Z_s} \quad (1)$$

where $V_s = V_s \angle \delta$, $V_l = V_l \angle 0$, $I_s = I_s \angle \phi$, and $Z_s = Z_s \angle \theta_s$, with V_s , V_l , I_s , Z_s , δ , ϕ , and θ_s are rms source voltage, rms load voltage, rms source current, feeder impedance, load angle, power factor angle, and feeder impedance angle, respectively. The three phase average load power (PI) is expressed as

$$P_l = \text{Real} [3 V_l \times I_s^*] \quad (2)$$

Substituting V_l and I_s in (2), the load active power is

$$P_l = \frac{3 V_l^2}{Z_s} \left[\frac{V_s}{V_l} \cos(\theta_s - \delta) - \cos \theta_s \right] \quad (3)$$

Rearranging (3), expression for δ is computed as follows:

$$\delta = \theta_s - \cos^{-1} \left[\frac{V_l}{V_s} \left(\cos \theta_s + \frac{P_l Z_s}{3 V_l^2} \right) \right] \quad (4)$$

For power transfer from source to load with stable operation in an inductive feeder, δ must be positive and less than 90° . Also, all the terms of the second part of (4), i.e., inside \cos^{-1} , are amplitude and will always be positive. Therefore, value of the second part will be between '0' to ' $\pi/2$ ' for the entire operation of the load. Consequently, the load angle will lie between θ_s to $(\theta_s - \pi/2)$ under any load operation, and therefore, maximum possible load angle is θ_s .

The vector expression for source voltage is given as follows:

$$V_s = V_l + I_s Z_s \angle (\theta_s + \phi) \quad (5)$$

A DSTATCOM regulates the load voltage by injecting fundamental reactive current. To demonstrate the DSTATCOM voltage regulation capability at different supply voltages for different R_s/X_s , vector diagrams using (5) are drawn in Fig.3. To draw diagrams, load voltage V_l is taken as reference phasor having the nominal value OA

(1.0 p.u.). With aim of making $V_l = V_s = 1.0$ p.u., locus of V_s will be a semicircle of radius V_l . Since, the maximum possible load angle is 90° in an inductive feeder, Phasor V_s can be anywhere inside curve OACBO. It can be seen that the value of $\theta_s + \phi$ must be greater than 90° for zero voltage regulation. Additionally, it is possible only when power factor is leading at the load terminals θ_s cannot be more than 90° .

Fig.3(a) shows the limiting case when $R_s/X_s = 1$, i.e., $\theta_s = 45^\circ$. From (4), the maximum possible load angle is 45° . The maximum value of angle, $\theta_s + \phi$, can be 135° when ϕ is 90° . Hence, the limiting source current phasor OE, which is denoted by I_s limit, will lead the load voltage by 90° . Lines OC and AB show the limiting vectors of V_s and $I_s Z_s$, respectively with D as the intersection point. Hence, area under ACDA shows the operating region of DSTATCOM for voltage regulation. The point D has a limiting value of V_s limit = $I_s Z_s = 0.706$ p.u. Therefore, maximum possible voltage regulation is 29.4%. However, it is impossible to achieve these two limits simultaneously as δ and ϕ cannot be maximum at the same time. Again if Z_s is low then source current, which will be almost inductive, will be enough to be realized by aDSTATCOM.

Fig.3(b) considers case when $R_s/X_s = \sqrt{3}$ i.e., $\theta_s = 30^\circ$. The area under ACDA shrinks, which shows that with the increase in R_s/X_s from the limiting value, the voltage regulation capability decreases. In this case the limiting values of V_s limit and $I_s Z_s$ are found to be 0.866 and 0.5 p.u., respectively. Here, maximum possible voltage regulation is 13.4%. However, due to high current requirement, a practical DSTATCOM can provide very small voltage regulation.

Voltage regulation performance curves for more resistive grid, i.e., $\theta_s = 15^\circ$, as shown in Fig.3(c), can be drawn similarly. Here, area under ACDA is negligible. For this case, hardly any voltage regulation is possible. Therefore, more the feeder is resistive in nature, lesser will be the voltage regulation capability.

Therefore, it is inferred that the voltage regulation capability of DSTATCOM in a distribution system mainly depends upon the feeder impedance. Due to resistive nature of feeder in distribution system, DSTATCOM voltage regulation capability is limited. Moreover, very high current is required to mitigate small voltage disturbances which results in higher rating of IGBT switches as well as increased losses. One more point worth to be noted is that, in the resistive feeder, there will become voltage drop in the line at nominal source voltage which the DSTATCOM may not be able compensate to maintain load voltage at 1.0 p.u. even with an ideal VSI.

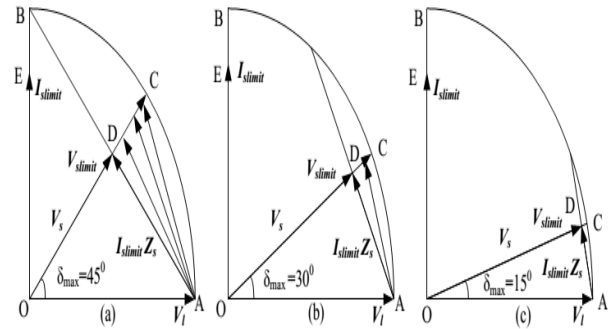

Fig.3. Voltage regulation performance curve of DSTATCOM at different R_s/X_s . (a) For $R_s/X_s = 1$. (b) For $R_s/X_s = \sqrt{3}$. (c) For $R_s/X_s = 3.73$.

IV. SELECTION OF EXTERNAL INDUCTOR FOR VOLTAGE REGULATION IMPROVEMENT AND RATING REDUCTION

A generalized procedure to select external inductor for improvement in DSTATCOM voltage regulation capability while reducing the current rating of VSI. Fig.4 shows single phase equivalent DSTATCOM circuit diagram in distribution system. With balanced voltages, source current will be

$$I_s = \frac{V_s \angle \delta - V_l \angle 0}{(R_s + R_{ext}) + j(X_s + X_{ext})} = \frac{V_s \angle \delta - V_l \angle 0}{R_{sef} + jX_{sef}} \quad (6)$$

Where $R_{sef} = R_s + R_{ext}$ and $X_{sef} = X_s + X_{ext}$ are effective feeder resistance and reactance, respectively. R_{ext} is equivalent series resistance (ESR) of external inductor,

and will be small. With $\theta_{sef} = \tan^{-1} \frac{X_{sef}}{R_{sef}}$ and $Z_{sef} = \sqrt{R_{sef}^2 + X_{sef}^2}$ as effective impedance angle and effective feeder impedance, respectively, the imaginary component of I_s given as

$$I_s^{im} = \frac{V_l \sin \theta_{sef} + V_s \sin (\delta - \theta_{sef})}{Z_{sef}} \quad (7)$$

With the addition of external impedance, the effective feeder impedance becomes predominantly inductive. Hence, $Z_{sef} \approx X_{sef}$. Therefore, approximated I_s^{im} will be

$$I_s^{im} = \frac{V_l \sin \theta_{sef} + V_s \sin (\delta - \theta_{sef})}{X_{sef}} \quad (8)$$

DSTATCOM Power rating (S_{vsi}) is given as follows [21]:

$$S_{vsi} = \sqrt{3} \frac{V_{dc}}{\sqrt{2}} I_{vsi} \quad (9)$$

Where I_{vsi} is the rms phase current rating of the VSI and V_{dc} is the voltage maintained at the dc capacitors. The DSTATCOM aims to inject harmonic and reactive current component offload currents. Suppose I_{lim} is the

maximum rms reactive and harmonic current rating of the load, then the value of compensator current used for voltage regulation (same as I_{sim}) is obtained by subtracting I_{lim} from I_{vsi} and given as follows:

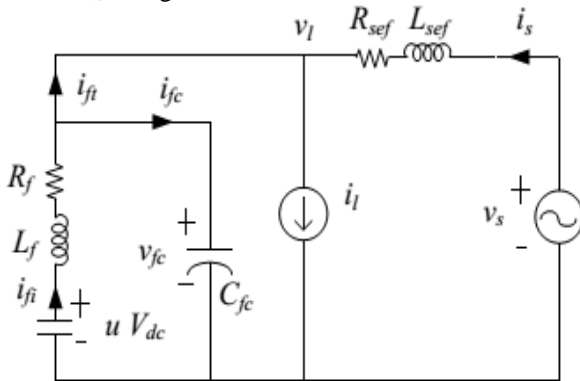

Fig.4. Single phase equivalent circuit of DSTATCOM topology with external inductor in distribution system

$$I = I_{vsi} - I_l^{im} = \frac{\sqrt{2}S_{vsi}}{\sqrt{3}V_{dc}} - I_l^{im} \quad (10)$$

Comparing (8) and (10) while using value of δ from (4), following expression is obtained:

$$X_{sef} = \frac{V_l \sin \theta_{sef} - V_s \sin \left[\cos^{-1} \left[\frac{V_l}{V_s} \left(\cos \theta_{sef} + \frac{P_l X_{sef}}{3V_l^2} \right) \right] \right]}{\frac{\sqrt{2}S_{vsi}}{\sqrt{3}V_{dc}} - I_l^{im}} \quad (11)$$

V. DESIGN EXAMPLE OF EXTERNAL INDUCTOR

Here, it is assumed that the considered DSTATCOM protects load from voltage sag of 60%. Hence, source voltage $V_s = 0.6$ p.u. is considered as worst case voltage disturbances. During voltage disturbances, the loads should remain operational while improving the DSTATCOM capability to mitigate the sag. Therefore, the load voltage during voltage sag is maintained at 0.9 p.u., which is sufficient for satisfactory operation of the load. In the present case, maximum required value of I_{lim} is 10 A. With the system parameters given in Table I, the effective reactance after solving (11) is found to be 2.2 Ω ($L_{sef} = 7$ mH). Hence, value of external inductance, L_{ext} , will be 6.7 mH. This external inductor is selected while satisfying the constraints such as maximum load power demand, rating of DSTATCOM, and amount of sag to be mitigated. In this design example, for base voltage and base power rating of 400V and 10 kVA, respectively, the value of external inductances 0.13 p.u.

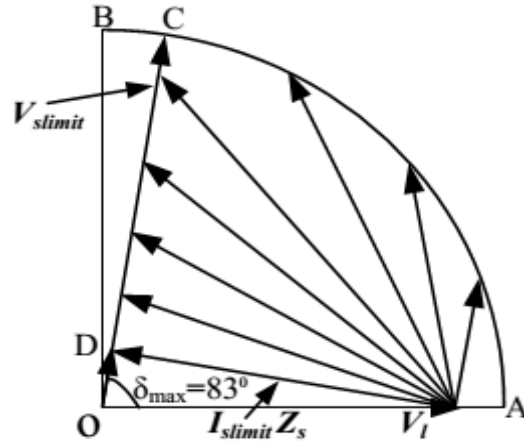

Fig.5. Voltage regulation performance of DSTATCOM with external inductance.

Moreover, with total inductance of 7 mH (external and actual grid inductance), the total impedance will be 0.137 p.u. The short circuit capacity of the line will be $1/0.13 = 7.7$ p.u. Which is sufficient for the satisfactory operation of the system? Additionally, a designer always has flexibility to find suitable value of L_{ext} if the constraints are modified or circuit conditions are changed. Moreover, conventional DSTATCOM operated for achieving voltage regulation uses large feeder inductances.

With the external inductance while neglecting its ESR, R_s/X_{sef} will be 0.13 i.e., $\theta_{sef} = 83^\circ$. Voltage regulation performance curves of the DSTATCOM in this case are shown in Fig.3.5, where the area under ACDA covers the majority of the stable operating range OABO. Hence, introduction of external inductor greatly improves the DSTATCOM voltage regulation capability. Additionally, due to increased effective feeder impedance the current requirement for sag mitigation also reduces. Moreover, if ESR of the external inductor is included, then the equivalent feeder impedance angle changes slightly (i.e., from 83 degree to 80.45 degree), and has negligible effect on the expression obtained in (11) as well as the voltage regulation capability of the DSTATCOM.

VI. FLEXIBLE CONTROL STRATEGY

A flexible control strategy to improve the performance of DSTATCOM in presence of the external inductor L_{ext} . Firstly, a dynamic reference load voltage based on the coordinated control of the load fundamental current, PCC voltage, and voltage across the external inductor is computed. Then, a proportional integral (PI) controller is used to control the load angle which helps in regulating the dc bus voltage at a reference value. Finally, three phase reference load voltages are generated. The block diagram of the control strategy is shown in Fig.6.

A. Derivation of Dynamic Reference Voltage Magnitude (V_l^*)

In conventional VCM operation of DSTATCOM, the reference load voltage is maintained at a constant value of 1.0p.u. [10]–[12]. Source currents cannot be controlled in this reference generation scheme. Therefore, power factor will not be unity and source exchanges reactive power with the system even at nominal supply. To overcome this limitation, a flexible control strategy is developed to generate reference load voltage. This scheme allows DSTATCOM to set different reference voltages during various operating conditions. The scheme is described in the following.

1) Normal Operation: It is defined as the condition when load voltage lies between 0.9 to 1.1 p.u. In this case, the proposed flexible control strategy controls load voltages such that the source currents are balanced sinusoidal and VSI does not exchange any reactive power with the source. Hence, the source supplies only fundamental positive sequence current component to support the average loads power and VSI losses. Reference source currents (i_{sj}^* where $j = a, b, c$ are three-phases), computed using instantaneous symmetrical component theory [22], are given as

$$i_{sj}^* = \frac{v_{pj1}^+}{\Delta_1^+} (P_l + P_{loss}) \quad (12)$$

Where. The voltages v_{pa1}^+, v_{pb1}^+ and v_{pc1}^+ are fundamental positive sequence components of PCC voltages. Average load power (P_l) and VSI losses (P_{loss}) are calculated using moving average filter (MAF) as follows:

$$P_l = \frac{1}{T} \int_{t_1-T}^{t_1} (v_{la}i_{la} + v_{lb}i_{lb} + v_{lc}i_{lc}) dt \quad (13)$$

$$P_{loss} = \frac{1}{T} \int_{t_1-T}^{t_1} (v_{la}i_{fta} + v_{lb}i_{ftb} + v_{lc}i_{ftc}) dt \quad (14)$$

The reference source currents must be in phase with the respective phase fundamental positive sequence PCC voltages for achieving UPF at the PCC. Instantaneous PCC voltage and reference source current in phase-a can be defined as follows:

$$v_{pa1}^+ = \sqrt{2}V_{pa1}^+ \sin(\omega t - \varphi_{pa1}^+), i_{sa}^* = \sqrt{2}I_{sa}^* \sin(\omega t - \varphi_{pa1}^+) \quad (15)$$

Where V_{pa1}^+ and φ_{pa1}^+ are rms voltage and angle of fundamental positive sequence voltage in phase-a, respectively. I_{sa}^* is the reference source current obtained from (12). With external impedance, the expected load voltage is given as follows:

$$V_{la} = V_{pa1}^+ - I_{sa}^* Z_{ext} \quad (16)$$

From (15) and (16), the load voltage magnitude will be

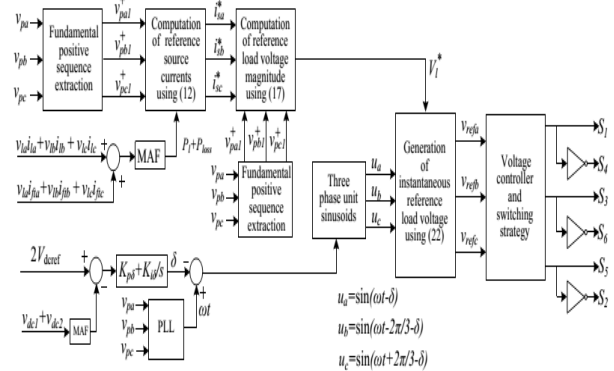

Fig.6. Block diagram of proposed flexible control strategy.

$$V_{la} = \sqrt{\left[(V_{pa1}^+ \cos \varphi_{pa1}^+ - I_{sa}^* Z_{ext} \cos(\theta_{ext} - \varphi_{pa1}^+))^2 + (V_{pa1}^+ \sin \varphi_{pa1}^+ - I_{sa}^* Z_{ext} \sin(\theta_{ext} - \varphi_{pa1}^+))^2 \right]} \quad (17)$$

With UPF at the PCC, the voltage across the external inductor will lead the PCC voltage by 90° . Neglecting ESR of external inductor, it can be observed that the voltage across external inductor improves the load voltage compared to the PCC voltage. This highlights another advantage of external inductor where it helps in improving the load voltage. As long as V_{la} lies between 0.9 to 1.1 p.u., same voltage is used as reference terminal voltage (V_l^*), i.e.,

$$\text{if } V_{la} \in [0.9 - 1.1 \text{ p.u.}], \text{ then } V_l^* = V_{la} \quad (18)$$

2) Operation during Sag: Voltage sag is considered when value of (17) is less than 0.9 p.u. To keep filter current minimum, the reference voltage is set to 0.9 p.u. Therefore,

$$V_l^* = 0.9 \text{ p.u.} \quad (19)$$

3) Operation during Swell: A voltage swell is considered when any of the PCC phase voltage exceeds 1.1 p.u. In this case, reference load voltage (V_l^*) is set to 1.1 p.u. which results in minimum current injection. Therefore,

$$V_l^* = 1.1 \text{ p.u.} \quad (20)$$

B. Computation of Load Angle (δ)

Average real power at the PCC (P_{pcc}) is sum of average load power (P_l) and VSI losses (P_{loss}). The real power P_{pcc} is taken from the source depending upon the angle between source and load voltages, i.e., load angle δ . If DSTATCOM dc bus capacitor voltage is regulated to a reference value, then in steady state condition P_{loss} is a constant value and forms fraction of P_{pcc} . Consequently, δ

is also a constant value. The dc link voltage is regulated by generating a suitable value of δ . The average voltage across dc capacitors ($V_{dc1} + V_{dc2}$) is compared with a reference voltage and error is passed through a PI controller. Output of PI controller, δ , is given as

$$\delta = K_{p\delta} e_{vdc} + K_{i\delta} \int e_{vdc} dt \quad (21)$$

Where $v_{dc} = 2 V_{dcref} - (V_{dc1} + V_{dc2})$ is the voltage error. $K_{p\delta}$ and $K_{i\delta}$ are proportional and integral gains, respectively.

C. Generation of Instantaneous Reference Voltage

Selecting suitable reference load voltage magnitude and computing load angle δ from (21), the three phases balanced sinusoidal reference load voltages are given as follows:

$$\begin{aligned} v_{refa} &= \sqrt{2} V_l^* \sin(\omega t - \delta) \\ v_{refb} &= \sqrt{2} V_l^* \sin(\omega t - 2\pi/3 - \delta) \\ v_{refc} &= \sqrt{2} V_l^* \sin(\omega t + 2\pi/3 - \delta) \end{aligned} \quad (22)$$

These voltages are realized by the VSI using a predictive voltage controller [23].

VII. DESIGN OF A FUZZY CONTROLLER

The difficulty regarding the PI controller gain is the fine tuning of the controller so as to achieve the optimal operation of the task. The major drawback of the PI controller is faced when the process is nonlinear and also when the system is having oscillations. Considering all these facts, a fuzzy logic controller was implemented. A fuzzy controller can work in linear as well as in nonlinear design parameters. FL requires some numerical parameters in order to operate such as what is considered significant error and significant rate-of-change-of-error, but exact values of these numbers are usually not critical unless very responsive performance is required in which case empirical tuning would determine them.

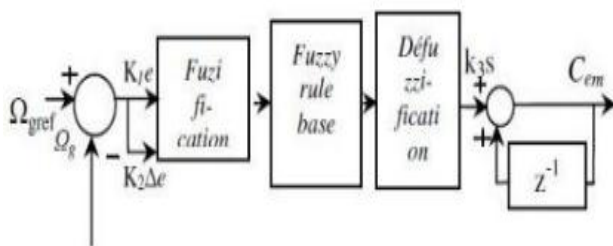

Fig.7 Fuzzy Logic Controller

FL requires some numerical parameters in order to operate such as what is considered significant error and significant rate-of-change-of-error,

but exact values of these numbers are usually not critical unless very responsive performance is required in which case empirical tuning would determine them. For example, a simple temperature control system could use a single temperature feedback sensor whose data is subtracted from the command signal to compute "error" and then time-differentiated to yield the error slope or rate-of change-of-error, hereafter called "error-dot".

VIII. MATLAB/SIMULATION RESULTS

Case I Conventional D-STATCOM

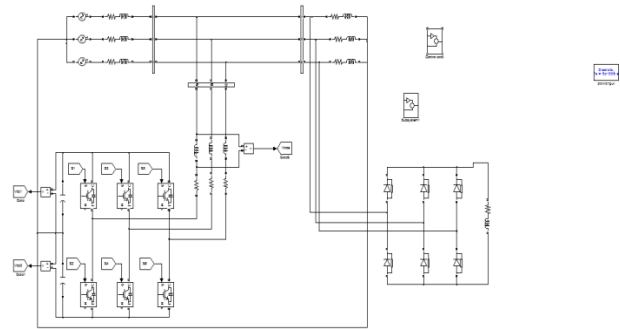
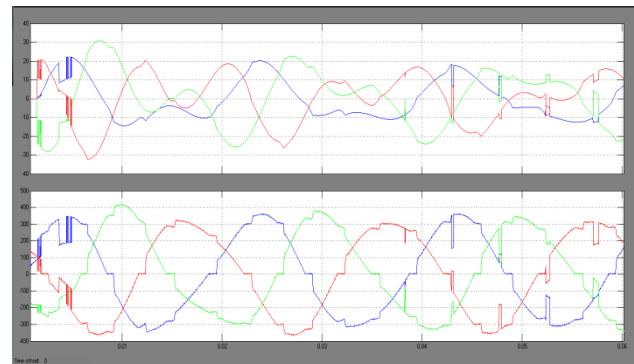
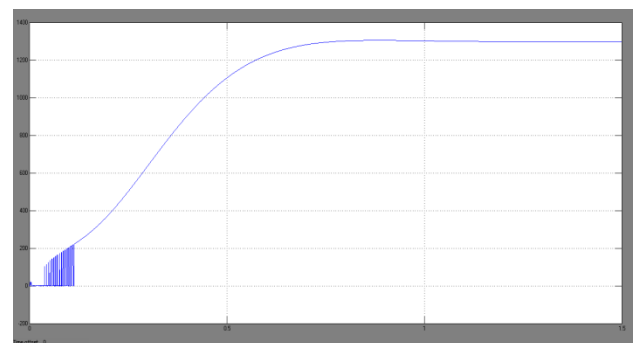

Fig.8. MATLAB/SIMULINK circuit for conventional D-STATCOM



(a) Simulation waveform of IabcT, VabcT



(b) Simulation waveform of Vdc1+vdc2

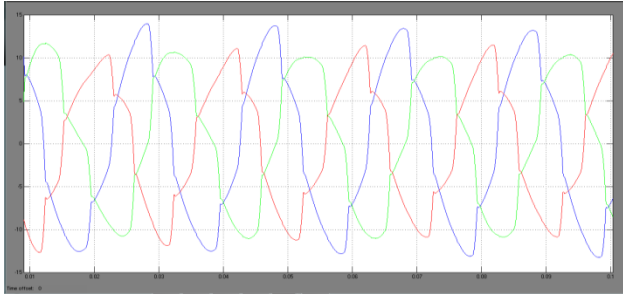

(c) Simulation waveform of load current IabcL

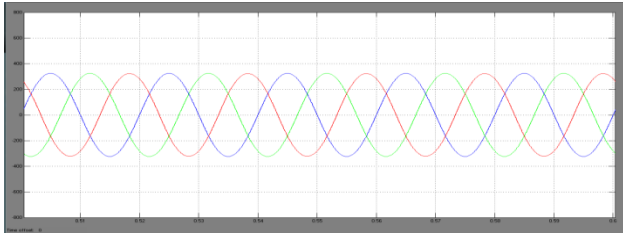

(d) Simulation waveform of load voltage VabcL

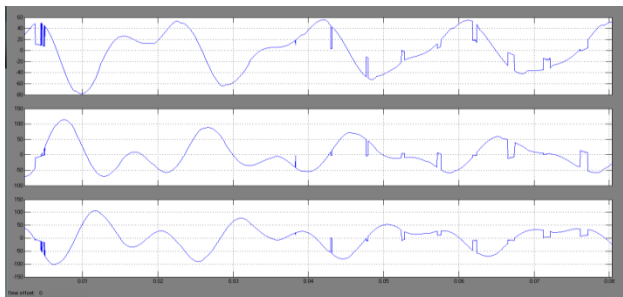

(e) Simulation waveforms of Filter currents

Fig.9. Voltage regulation performance of conventional DSTATCOM with resistive feeder

Case-II: Proposed D-STATCOM

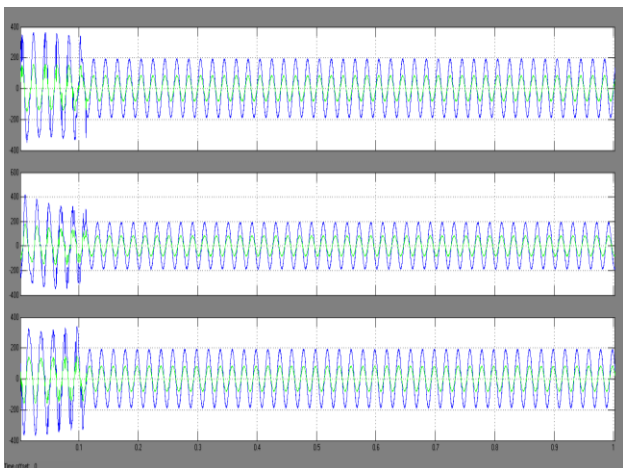

(a) Simulation waveforms of D-STATCOM IabcT, VabcT

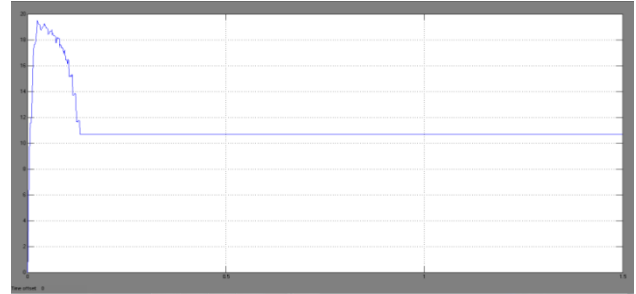

(b) Simulation waveforms of D-STATCOM IabcT RMS

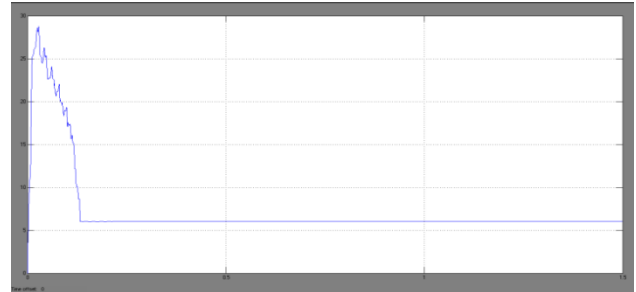

(c) Simulation waveform of D-STATCOM RMS 1 filter current

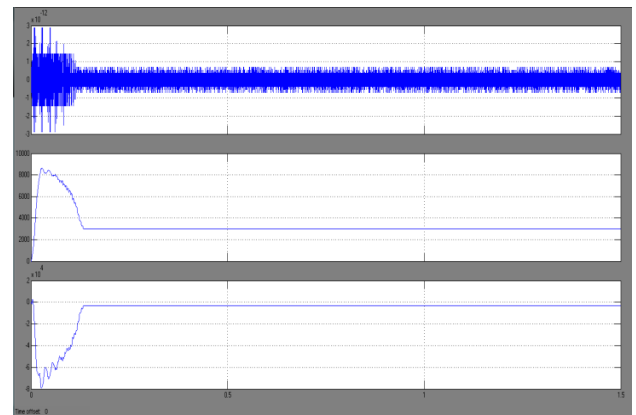

(d) Simulation Waveform of D-STATCOM PQ values Reactive power

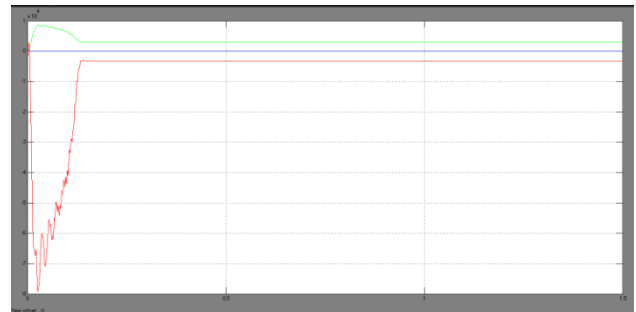

(e) Simulation waveforms of D-STATCOM filter current, load current, load voltage

Fig.10. Proposed D-STATCOM outputs

Case III: Proposed D-STATCOM on Sag condition

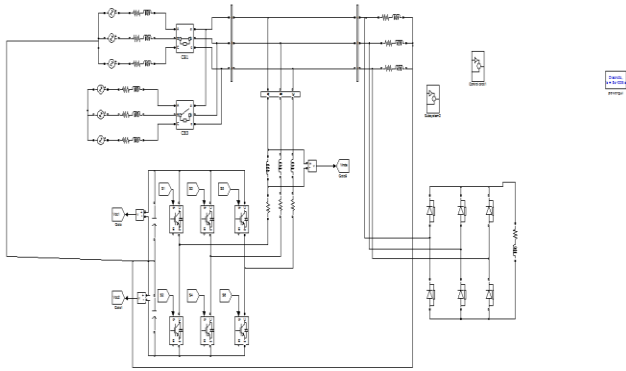
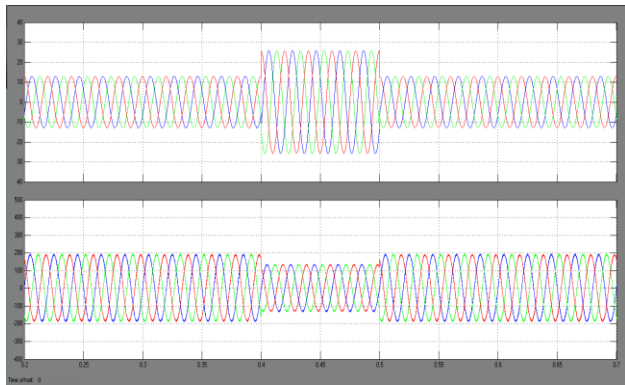
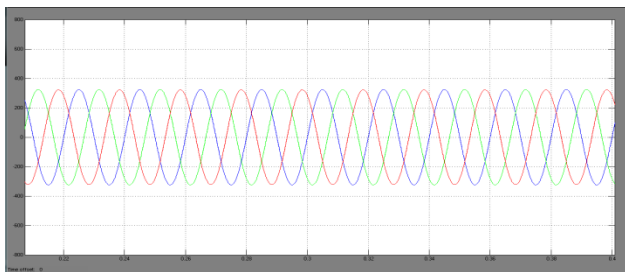

Fig.11. MATLAB/SIMULINK circuit for proposed Stat com on Sag condition



(a) Simulation waveform for Proposed D-statcom of IabcT, voltage sag VabcT



(b) Simulation waveform for Proposed D-statcom of vabcL

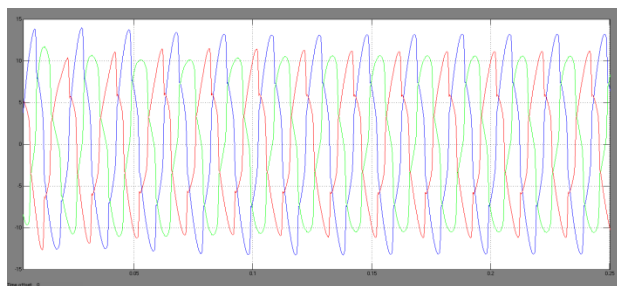

(c) Simulation waveform for Proposed D-statcom of IabcL

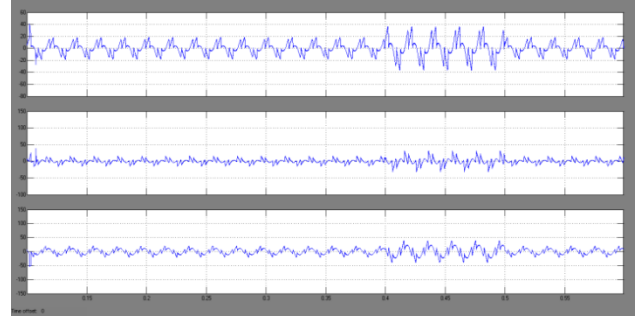

(d) Simulation waveform for Proposed D-statcom for Field currents

Fig.12. Proposed DSTATCOM on Sag condition

Case IV: Proposed D Statcom on Swell condition

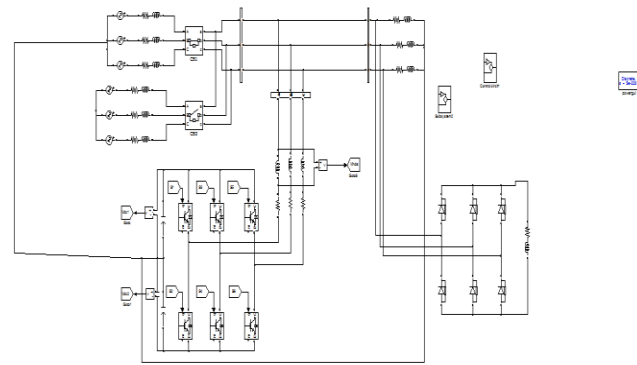
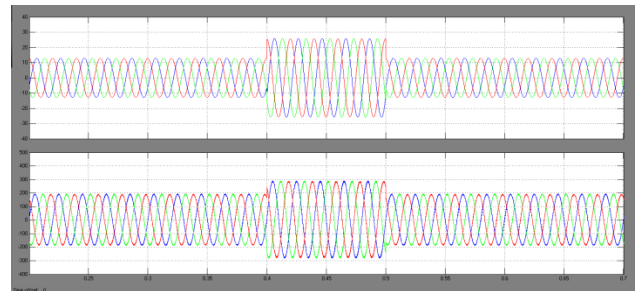
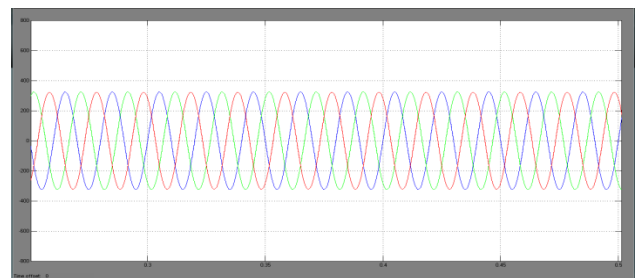

Fig.13. MATLAB/SIMULINK circuit for proposed D Statcom on Swell condition



(a) Simulation waveform for Proposed D-statcom of IabcT, voltage swell VabcT



(b) Simulation waveform for Proposed D-statcom of vabcL

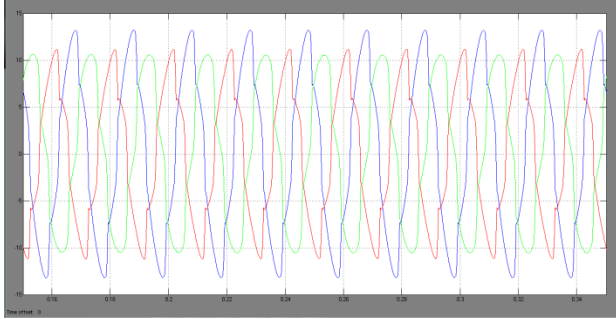

(c) Simulation waveform for Proposed D-statcom of IabcL

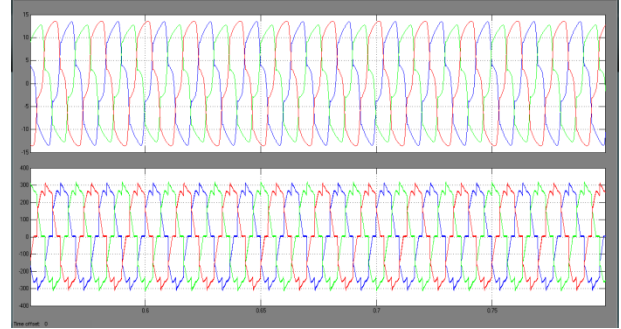

(a) Simulation waveform for IabcT, VabcT without D-STATCOM

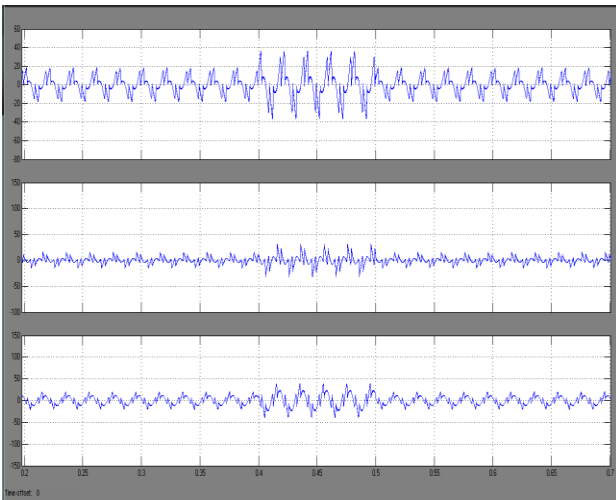

(d) Simulation waveform for Proposed D-statcom for Field currents

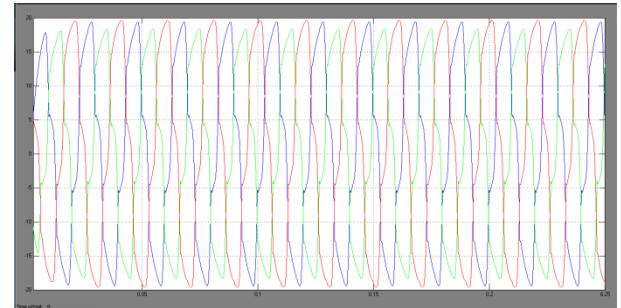

(b) Simulation waveform for IabcL without STATCOM
 Fig.16. Simulation waveforms without DSTATCOM

Fig.14. Simulation results (a) During normal operation (case 2). (b) During voltage sag (case 3). (c) During voltage swell (case 4).

Case V: System without DSTATCOM

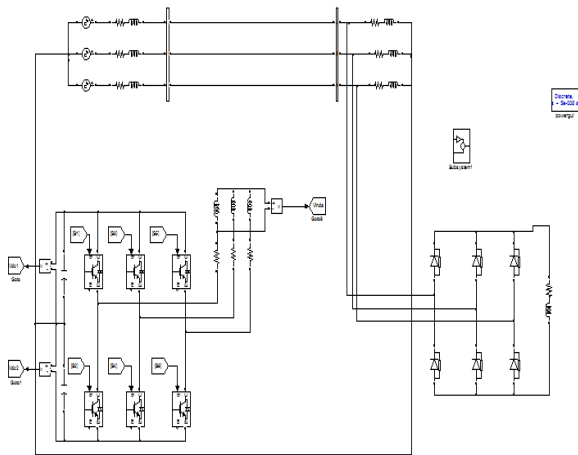

Fig.15. MATLAB/SIMULINK circuit without D-STATCOM

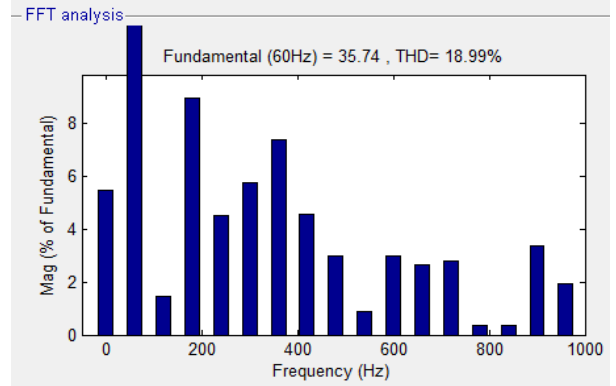

Fig.17. THD of proposed DSTATCOM

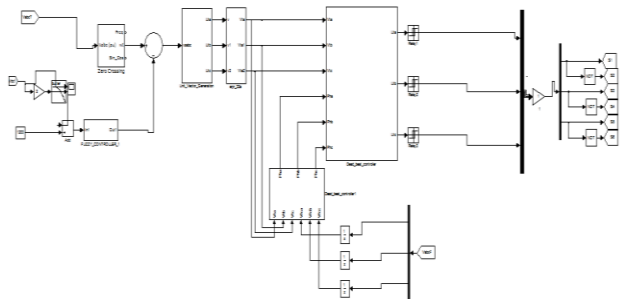

Fig.18. MATLAB/SIMULINK control circuit for D-STATCOM with fuzzy logic controller

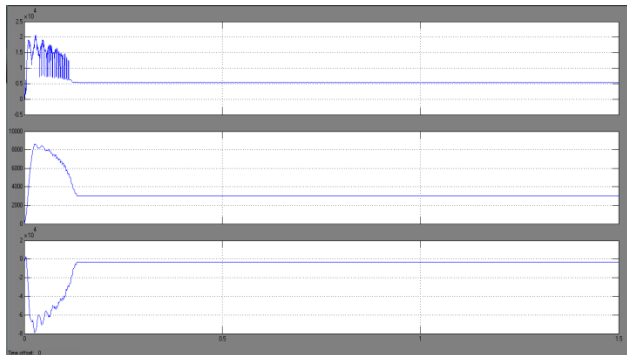

Fig.19. Simulation waveform of Reactive power components of DSTATCOM with fuzzy controller

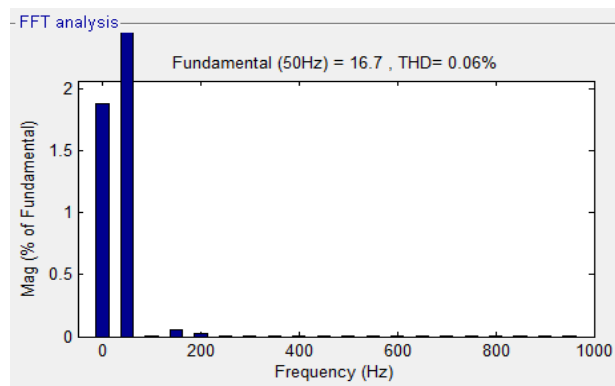

Fig.20. THD of DSTATCOM with fuzzy logic controller

IX. CONCLUSION

In this paper, to protect the load from voltage disturbances under stiff source a new fuzzy based control algorithm for multifunctional DSTATCOM has been proposed. This has been achieved by placing an external series inductance of suitable value between the source and the load. In addition, instantaneous reference voltage is controlled in such a way that the source currents are indirectly controlled, and the advantages of CCM operation are achieved while operating in VCM for a permissible range of source voltage. The proposed algorithm and multifunctional DSTATCOM are able to mitigate voltage- and current-related PQ issues, and the THD analysis revealed that the fuzzy logic controller is good.

REFERENCES

[1] M. H. Bollen, Understanding power quality problems. vol. 3, IEEEpress New York, 2000.
[2] S. Ostroznik, P. Bajec, and P. Zajec, "A study of a hybrid filter," IEEETrans. Ind. Electron. vol. 57, no. 3, pp. 935–942, Mar. 2010.
[3] C. Kumar and M. Mishra, "A voltage-controlled DSTATCOM for power quality improvement," IEEE Trans. Power Del., vol. 29, no. 3, pp. 1499–1507, June 2014.

[4] Q. Liu, L. Peng, Y. Kang, S. Tang, D. Wu, and Y. Qi, "A novel design and optimization method of an LCL filter for a shunt active power filter," IEEE Trans. Ind. Electron., vol. 61, no. 8, pp. 4000–4010, Aug. 2014.
[5] T. Aziz, M. Hossain, T. Saha, and N. Mithulananthan, "VAR planning with tuning of STATCOM in a DG integrated industrial system," IEEETrans. Power Del., vol. 28, no. 2, pp. 875–885, Apr. 2013.
[6] S. Karanki, N. Geddada, Mahesh K. Mishra, and B. Kumar, "ADSTATCOM topology with reduced dc-link voltage rating for load compensation with non stiff source," IEEE Trans. Power Electron, vol. 27, no. 3, pp. 1201–1211, Mar. 2012.
[7] M. Aredes, J. Hafner, and K. Heumann, "Three-phase four-wire shunt active filter control strategies," IEEE Trans. Power Electron., vol. 12, no. 2, pp. 311–318, Mar. 1997.
[8] B. Singh, K. Al-Haddad, and A. Chandra, "A new control approach to three-phase active filter for harmonics and reactive power compensation," IEEE Trans. Power Sys., vol. 13, no. 1, pp. 133–138, Feb 1998.
[9] S. Narula, B. Singh, and G. Bhuwaneswari, "Improved power-quality based welding power supply with over current handling capability," IEEETrans. Power Electron., vol. 31, no. 4, pp. 2850–2859, April 2016.
[10] H. Fujita and H. Akagi, "Voltage-regulation performance of a shunt active filter intended for installation on a power distribution system," IEEE Trans. Power Electron., vol. 22, no. 3, pp. 1046–1053, May 2007.
[11] R. Gupta, A. Ghosh, and A. Joshi, "Performance comparison of VSC based shunt and series compensators used for load voltage control in distribution systems," IEEE Trans. Power Del., vol. 26, no. 1, pp. 268–278, Jan. 2011.
[12] Mahesh K. Mishra, A. Ghosh, and A. Joshi, "Operation of a DSTATCOM in voltage control mode," IEEE Trans. Power Del., vol. 18, no. 1, pp. 258–264, Jan. 2003.
[13] A. Jain, K. Joshi, A. Behal, and N. Mohan, "Voltage regulation with STATCOMs: modeling, control and results," IEEE Trans. Power Del., vol. 21, no. 2, pp. 726–735, Apr. 2006.
[14] B. Singh and G. Kasal, "Solid state voltage and frequency controller for a standalone wind power generating system," IEEE Trans. Power Electron., vol. 23, no. 3, pp. 1170–1177, May 2008.
[15] B. Singh, S. Murthy, and S. Gupta, "Analysis and design of statcom based voltage regulator or self-excited induction generators," IEEETrans. Energy Conver., vol. 19, no. 4, pp. 783–790, Dec 2004.