

Fabrication and Demonstrating Of Solar Powered Air Cooler with Cooling Cabin for Household Food Items

KALLEPALLI MANOJ

*Assistant professor, Dept. Mechanical engineering mother Theresa College of engg & tech.
Peddapalli, , india
E-Mail: kallepallimanoj9@gmail.com*

In hot and humid conditions the need to feel relaxed and comfortable has become one of few needs and for this purpose utilization of systems like air-conditioning and refrigeration has increased rapidly. These systems are most of the time not suitable for villages due to longer power cut durations and high cost of products. Solar power systems being considered as one of the path towards more sustainable energy systems, considering solar-cooling systems in villages would comprise of many attractive features. This technology can efficiently serve large latent loads and greatly improve indoor air quality by allowing more ventilation while tightly controlling humidity. Despite increasing performance and mandatory energy efficiency requirements, peak electricity demand is growing and there is currently no prevalent solar air cooling technology suited to residential application especially for villages, schools and offices. This project reviews solar powered air cooler with cooling cabin for household food items hence their viability for residential application.

Keywords: Solar energy, Cooling cabin, Centrifugal fan, 3D modelling

INTRODUCTION

This paper reveals the comfort conditions achieved by the device for the human body. In summer (hot) and humid conditions feel uncomfortable because of hot weather and heavy humidity. So it is necessary to maintain thermal comfort conditions. Thermal comfort is determined by the room's temperature,

humidity and air speed. Radiant heat (hot surfaces) or radiant heat loss (cold surfaces) are also important factors for thermal comfort. Relative Humidity (RH) is a measure of the moisture in the air, compared to the potential saturation level. Warmer air can hold more moisture. When you approach 100% humidity, the air moisture condenses—this is called the

dew point. The temperature in a building is based on the outside temperature and sun loading plus whatever heating or cooling is added by the HVAC or other heating and cooling sources. Room occupants also add heat to the room since the normal body temperature is much higher than the room temperature.

The present air cooling methods are evaporative coolers, air conditioning, fans and dehumidifiers. But running these products need a source called electricity. The producing of electricity is ultimately responsible for hot and humid conditions, i.e., global warming. Need of such a source which is abundantly available in nature, which does not impose any bad effects on earth. There is only one thing which can come up with these all problems is solar energy.

PRESENT PROBLEM

The producing of electricity is ultimately responsible for hot and humid conditions, i.e., global warming. As in below shown chart it is clear that major quantity of electricity is produced by coal (fossil fuel).

- Fossil fuels also contain radioactive materials, mainly uranium and thorium, which are released into the atmosphere.
- Electricity generation produces nitrogen oxides and sulphur dioxide emissions, which contribute to smog and acid rain, emit carbon dioxide, which may contribute to climate change.
- Longer power cut durations in villages and high cost of cooling products.

PROPOSED SOLUTION

Need of such a source which is abundantly available in nature, which does not impose any

Figure 1: Production of Electricity from Different Sources

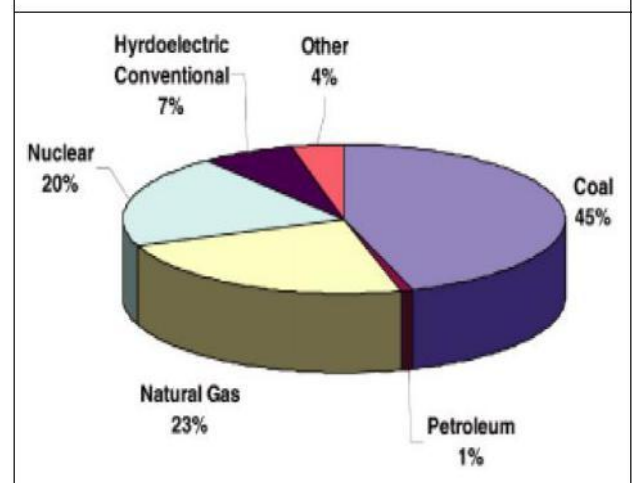

bad effects on earth. There is only one thing which can come up with these all problems is solar energy.

Solar energy, radiant light and heat from the sun, is harnessed using a range of technologies such as solar heating, solar photovoltaic's. The Earth receives 174 petawatts (PW) of incoming solar radiation. Approximately 30% is reflected back to space while the rest is absorbed by clouds, oceans and land masses. Photovoltaic's is a method of generating electrical power by converting solar radiation into direct current electricity by photovoltaic effect.

Objective of the Project

- To make aware of non conventional energy sources to reduce environmental pollutions.
- This product preferably suitable for villages, because they face lot of power cut problems in summer (around 12 to 14 hrs in day). And for offices and schools which runs in day to which save energy.
- As air-conditioning and refrigeration consumes more power and mainly cost of

refrigerating and air conditioning products are very high. So would like develop product which runs by solar energy and provide cooling effect for house hold food items at lower cost.

WORKING METHODOLOGY

This project mainly consist of three sections,

Solar Energy Conversion

Solar energy conversion is done by using battery, inverter and charge controller. As sun light falls on solar panel, which converts into electrical energy by photoelectric effect. This electrical energy stored in battery in the form of chemical energy. Charge controller is employed in between solar panel and battery which prevents overcharging and may

protect against overvoltage, which can reduce battery performance or lifespan, and may pose a safety risk. The stored energy directly can used for DC loads or else need to be converted AC (alternate current) by the help of inverter. Below shown figure explains solar energy conversion.

Cool Air Generation by Centrifugal Fan

The converted energy is used to run the centrifugal fan. This fan covered with cooling pads, through which water is passed at a specific rate. As the fan sucks the hot air through cooling pads, heat transfer occur between air and water thus generated cool air enters into the room.

protect

Figure 2: Solar Energy Conversion Process

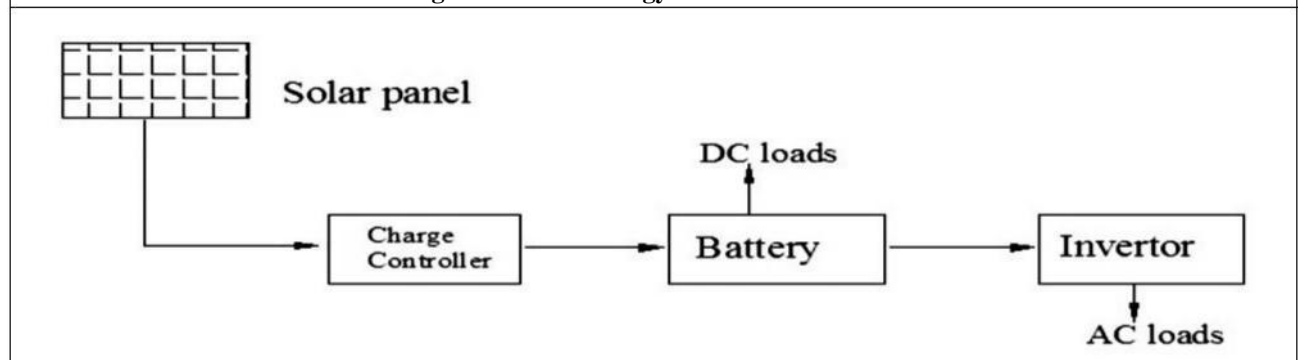
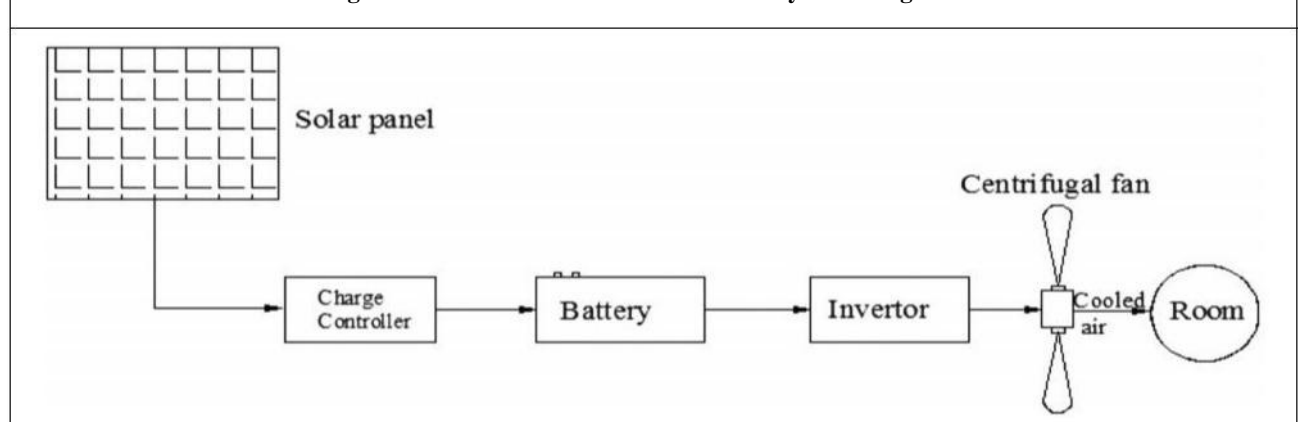

Figure 3: Process of Cool Air Generation by Centrifugal Fan



Cooling Cabin for Household Food Items

First thing, here it is natural cooling process. Cooling cabin is provided just below the air cooler section. This cabin built is up with cooling pads and ceramic slabs. Ceramic slabs are surrounded by cooling pads through continuous water supply is provided. This process leads to producing cooler region in the cabin. So this cabin can be used for preservation of food.

WORKING MODEL OF THE PROJECT

The above shown model consists of energy conversion unit, air cooler unit and cooling cabin. As the electrical energy supplied to the fan from inverter, it starts to produce airflow to the room at the same time water passed through the cooling pads. Fan sucks the outside air through the cooling pads, so heat transfer occur between air and water. So the cool air enters into the room. Next thing is

Figure 4: Construction of Natural Cooling Cabin for Food Items

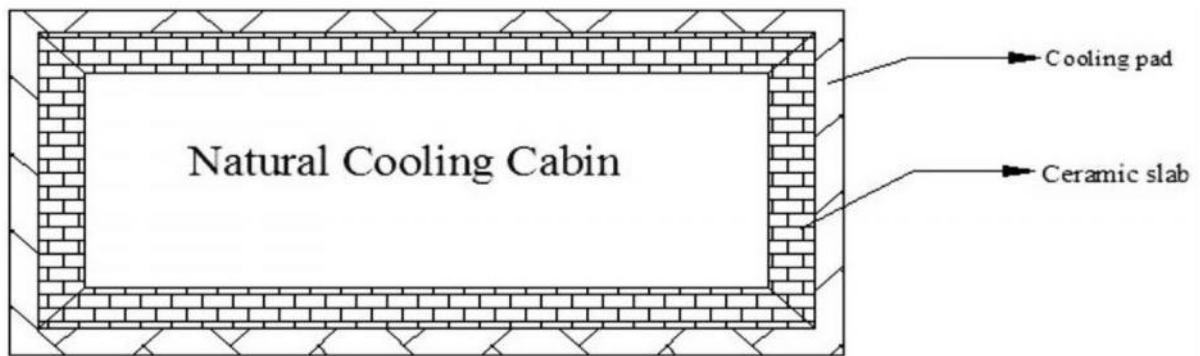
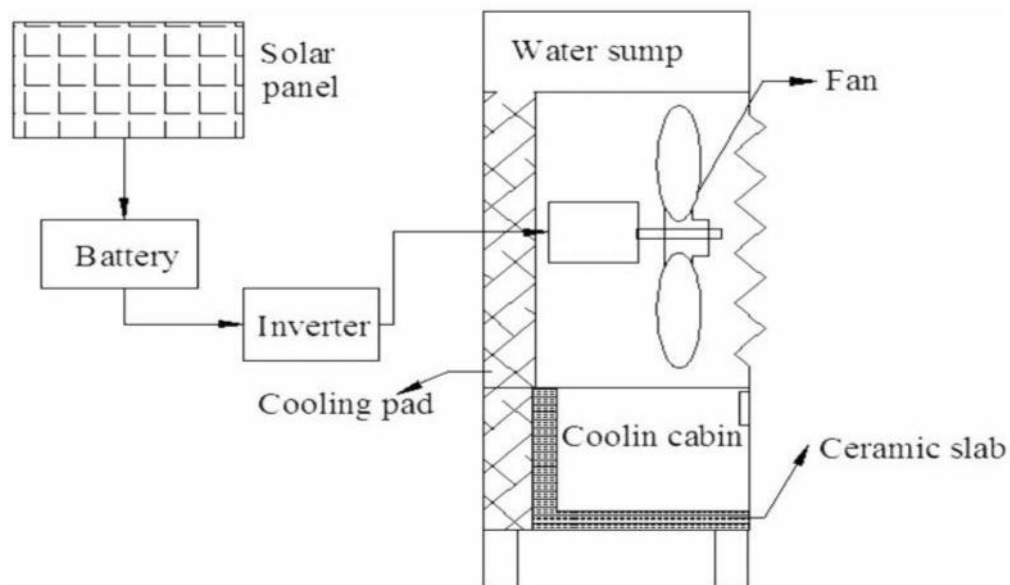

Figure 5: Solar Air Cooler with Cooling Cabin



cooling cabin provided just below the air cooler section. This cabin built is up with cooling pads and ceramic slabs. Ceramic slabs are surrounded by cooling pads through continuous water supply is provided. This process leads to producing cooler environment in the cabin. So this cabin can be used for preservation of food.

DESIGN CONSIDERATIONS OF THE PROJECT

Capacity of the fan required for a particular area can be calculated as:

Criteria: With supply of water through the cooling pads.

So, heat transfer between water and the air is given by following equation

$$m_w^* \frac{c_w (T_1 - T_2)}{V_{s1} (h_{a1} - h_{a2})} = \dots(1)$$

where as

m_w – Mass of water entering into the cooling pads per minute

V – Volume of air (m^3) entering into the room per minute (min)

V_{s1} – Specific volume of air entering into the cooling room

h_{a1} – Enthalpy per kg of dry air at T_1

h_{a2} – Enthalpy per kg of dry air at T_2

w_1 – Mass of vapour per kg of dry air at T_1

w_2 – Mass of vapour per kg of dry air at T_2

Considered conditions,

$T_1 = 30^\circ\text{C}$ and $T_2 = 25^\circ\text{C}$

Relative humidity = 60%

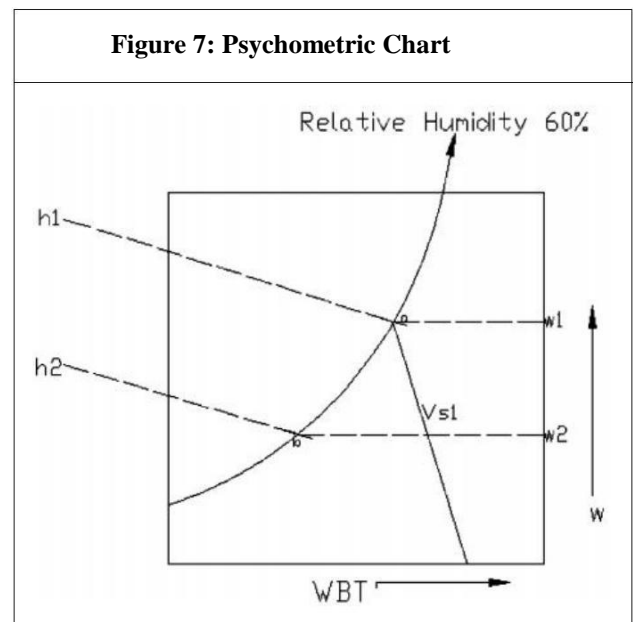
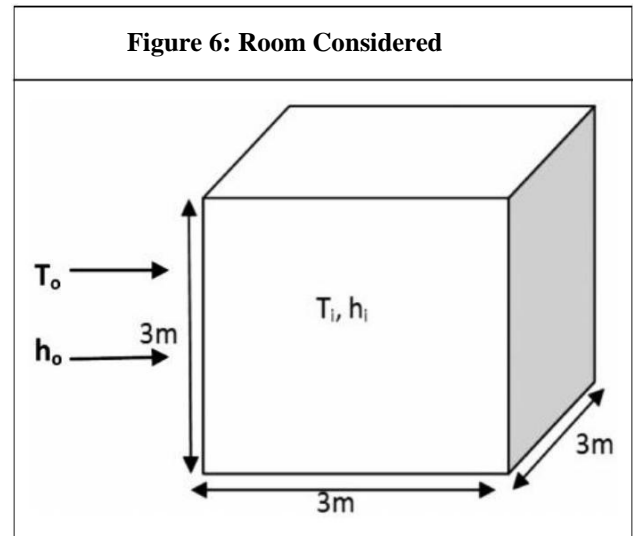

$m_w = 2$ kg of water per minute (assumed)

From: Psychrometric chart

$h_{a1} = 72.5$ KJ/Kg of dry air

$= 17.31$ kcal/kg

$h_{a2} = 56$ KJ/Kg of dry air

$= 13.37$ kcal/kg

$w_1 = 0.016$ grams/kg of dry air

$w_2 = 0.012$ grams/kg of dry air

$V_{s1} = 0.880$ m³/kg

Substituting above mentioned values in Equation (1)

$$2 * \frac{30 * 25 * 0.880 * 17.31 * 13.37 * 0.016}{0.012 * 25} = \dots$$

$$V = 2.291 \text{ m}^3 / \text{min} \approx 2.5 \text{ m}^3 / \text{min}$$

So the fan capacity of 2.5 m³/min is selected.

Capacity Solar Panel and Battery Required

Hence selected Blower (Fan) Specification:
 230 v, 50 Hz, 35 W

So to run 35 W blower on for 1 hour will take

35*1 = 35 Wh from the battery (Battery capacity is measured in Amp hours)

Convert this to watt hours by multiplying the Ah by the battery voltage

For 10 Ah, 12 v battery the watt hours is given by

$$P = V * I \quad \dots(2)$$

$$V = 12 \text{ v and } I = 10 \text{ Ah}$$

$$P = 10 * 12 = 120 \text{ Wh}$$

So, the 35 W centrifugal fan runs for

$$120 / 35 = 3.42 \approx 3.5 \text{ h}$$

This means the battery could supply 35 W blower for $3 \frac{1}{2}$ hours.

Energy generating capacity of solar panel over a period of time:

To calculate the energy it can supply to the battery, multiply watts by the hours exposed to sunlight, then multiply the result by 0.85 (This factor allows for natural system losses).

For the solar 40 W panel in 4 hours sunshine, 40*4*0.85 = 136 Wh

For 1 hour, 40*1*0.85 = 34 Wh

So the solar panel of 40 W and battery of 10 Ah are selected (Office purpose).

3D MODELLING OF THE COOLER FAN

Modelling of the cooler fan has been done with the help of modeling software NX 8.0, formerly known as NX Unigraphics, is an advanced CAD/CAM/CAE software package developed by Siemens PLM Software.

It is used among other tasks for:

- Design (parametric and direct solid/surface modeling).
- Manufacturing finished design by using included machining modules.

Figure 8: 3D Model of the Impeller

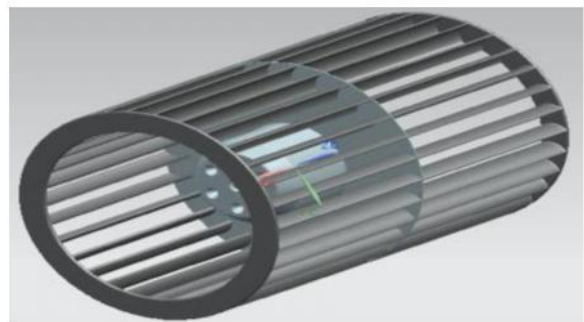
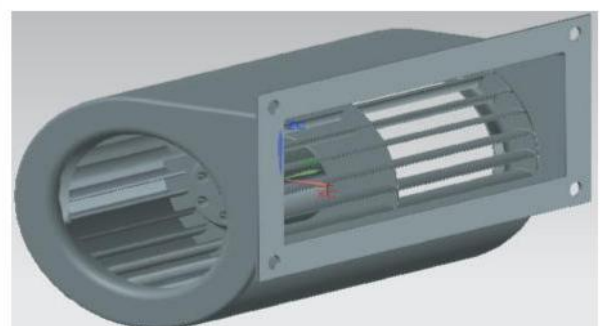

Figure 9: 3D Model of the Impeller Inserted in Casing



Below shown images are captured from NX 8.0.

Figure 10: Section View of the Fan

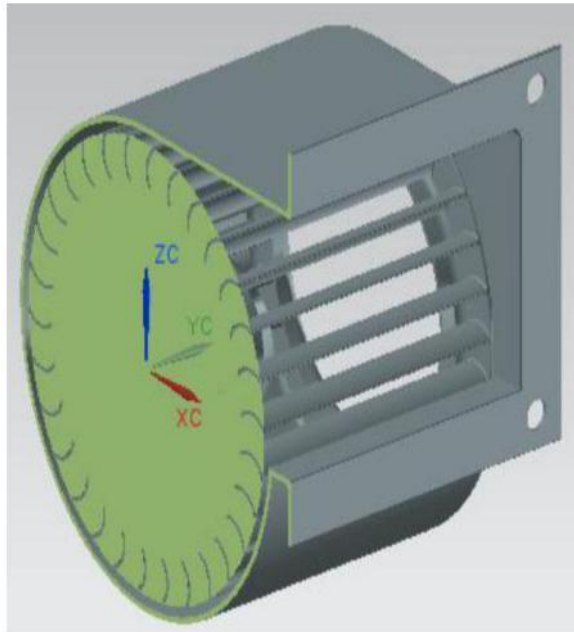
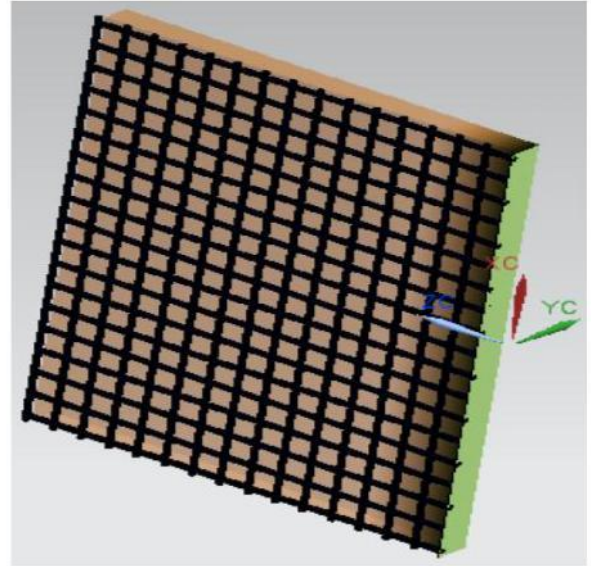

Figure 11: Cooling Pad Placed Between Metal Meshes



- Comfort thermal conditions achieved in the living room. That is room temperature up to 24 °C and relative humidity of 60%.
- At lower cost natural cooling cabin for preservation of food has been developed.

RESULTS AND DISCUSSION

The output of the project is

Table 1: Temperature Achieved in Cooling Cabin with Respect to Time

Time (min)	15	30	45	60	75	90	105
Temperature (°C)	28	26	23	21	20	18	17

Table 2: Cost Estimation

S. No.	Components name	Qty.	Cost (Rs.)
1.	Solar panel	1	1000
2.	Fan	1	1000
3.	Cooling Pad	2	200
4.	Ceramic slab	5	300
5.	UPS	1	2000
6.	Frame material	–	1500
7.	Fabrication charges	–	1000
8.	Miscellaneous	–	150
	Total		7150

CONCLUSION

So as comparing the cost of this product with the existing products in the market is, solar product appeals better and affordable by common people. This solar product perfectly suits for villages, schools and offices and thus prevention from the power cut problems. It comprises of many attractive features such as usage of solar energy, cooler and cooling cabin at lower cost. The above method is eco friendly and natural, electricity savers.

Durability of our product is more thus minimizing the cost. No electricity is spent so this product saves the energy and saves environment from getting polluted. 🌱

REFERENCES

1. Alosaimy A S (2013), “Application of Evaporative Air Coolers Coupled with Solar Water Heater for Dehumidification

of Indoor Air”, *International Journal of Mechanical & Mechatronics Engineering*, Vol. 13, No. 01, pp. 60-68.

2. Arora S C and Domkundwar S (1988), “A Course in Power Plant Engineering”, A Text Book.
3. Farhan Khmamas (2012), “Improving the Environmental Cooling for Air-Coolers by Using the Indirect-Cooling Method”, *ARPJ Journal of Engineering and Applied Sciences*, Vol. 5, No. 2, pp. 66-73.
4. SERI (1982), “Basic Photovoltaic Principles and Methods”, SERI/SP-290-1448, Solar Information Module 6213.
5. Srinivas Reddy B and Hemachandra Reddy K (2007), “Thermal Engineering Data Hand Book”, I K International Publishing House.