

# Enumerating Heat Transfer Rate of Cylinder Fin Body by Varying Geometry and Material

ARUKALA KRISHNA

*Assistant professor, Dept. Mechanical engineering mother Theresa College of engg & tech.  
Peddapalli, , india*

*E-Mail: [arukalakrishna77@gmail.com](mailto:arukalakrishna77@gmail.com)*

The Engine cylinder is one of the major automobile components, which is subjected to high temperature variations and thermal stresses. In order to cool the cylinder, fins are provided on the cylinder to increase the rate of heat transfer. By doing thermal analysis on the engine cylinder fins, it is helpful to know the heat dissipation inside the cylinder. The principle implemented in this project is to increase the heat dissipation rate by using the invisible working fluid, nothing but air. We know that, by increasing the surface area we can increase the heat dissipation rate, so designing such a large complex engine is very difficult. The main purpose of using these cooling fins is to cool the engine cylinder by air. The main aim of the project is to analyze the thermal properties by varying geometry, material and thickness of cylinder fins. Parametric models of cylinder with fins have been developed to predict the transient thermal behavior. The models are created by varying the geometry, rectangular, circular and curved fins. Present thickness of the fin is 3mm, it is reduced to 2.5mm. The 3D modeling software used is Pro/ Engineer. Presently Material used for manufacturing cylinder fin body is Aluminum Alloy 204 which has thermal conductivity of 110-150W/mk. In our project, it is replaced with Aluminum alloy 7075, Magnesium alloy and Beryllium and the total analysis is done in Ansys.

Keywords: Engine cylinder fins, Thermal analysis, Aluminum alloy 7075, Magnesium alloy, Beryllium

## INTRODUCTION

The internal combustion engine is an engine in which the combustion of a fuel (normally a fossil fuel) occurs with an oxidizer (usually air) in a combustion chamber. In an internal combustion engine, the expansion of the high-temperature and -pressure gases produced by combustion applies direct force to some component of the engine, such as

pistons, turbine blades, or a nozzle. This force moves the component over a distance, generating useful mechanical energy.

### Necessity of Cooling System in IC Engines

All the heat produced by the combustion of fuel in the engine cylinders is not converted into useful power at the crankshaft. A typical distribution for the fuel energy is given below:

Useful work at the crank shaft	= 25 %
Loss to the cylinders walls	= 30 %
Loss in exhaust gases	= 35 %
Loss in friction	= 10 %

It is seen that the quantity of heat given to the cylinder walls is considerable and if this heat is not removed from the cylinders it would result in the preignition of the charge. In addition, the lubricant would also burn away, thereby causing the seizing of the piston. Excess heating will also damage the cylinder material.

Keeping the above factors in view, it is observed that suitable means must be provided to dissipate the excess heat from the cylinder walls, so as to maintain the temperature below certain limits.

However, cooling beyond optimum limits is not desirable, because it decreases the overall efficiency due to the following reasons:

1. Thermal efficiency is decreased due to more loss of heat to the cylinder walls.
2. The vaporization of fuel is less; this results in fall of combustion efficiency.
3. Low temperatures increase the viscosity of lubrication and hence more piston friction is encountered, thus decreasing the mechanical efficiency.

Though more cooling improves the volumetric efficiency, yet the factors mentioned above result in the decrease of overall efficiency. Thus it may be observed that only sufficient cooling is desirable and any deviation from the optimum limits will result in the deterioration of the engine performance.

## **Methods of Cooling**

Various methods used for cooling of automobile engines are:

1. Air cooling
2. Water cooling

### **Air-Cooling**

Cars and trucks using direct air cooling (without an intermediate liquid) were built over a long period beginning with the advent of mass produced passenger cars and ending with a small and generally unrecognized technical change. Before World War II, water cooled cars and trucks routinely overheated while climbing mountain roads, creating geysers of boiling cooling water. This was considered normal, and at the time, most noted mountain roads had auto repair shops to minister to overheating engines.

ACS (Auto Club Suisse) maintains historical monuments to that era on the Susten Pass where two radiator refill stations remain (See a picture here). These have instructions on a cast metal plaque and a spherical bottom watering can hanging next to a water spigot. The spherical bottom was intended to keep it from being set down and, therefore, be useless around the house, in spite of which it was stolen, as the picture shows.

During that period, European firms such as Magirus-Deutz built air-cooled diesel trucks, Porsche built air-cooled farm tractors, and Volkswagen became famous with air-cooled passenger cars. In the USA, Franklin built air-cooled engines. The Czechoslovakia based company Tatra is known for their big size air cooled V8 car engines, Tatra engineer Julius Mackerle published a book on it. Air

cooled engines are better adapted to extremely cold and hot environmental weather temperatures, you can see air cooled engines starting and running in freezing conditions that stuck water cooled engines and continue working when water cooled ones start producing steam jets.

### Liquid Cooling

Today, most engines are liquid-cooled

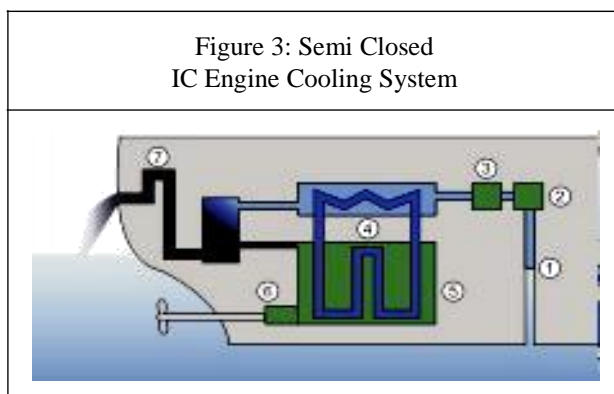
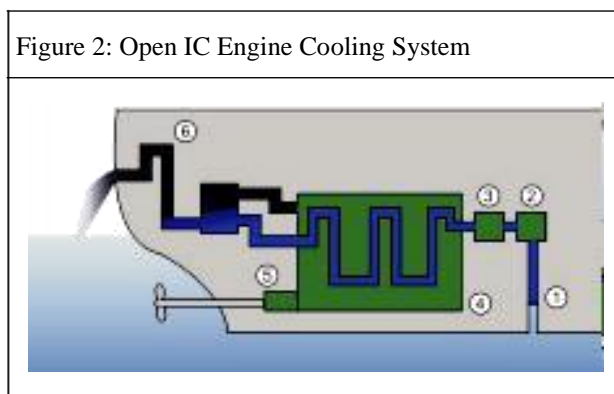
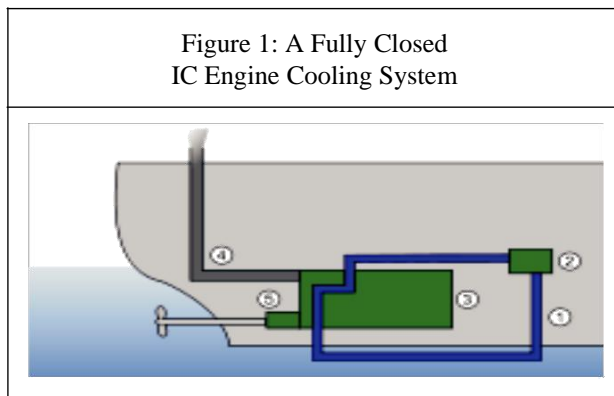

Liquid cooling is also employed in maritime vehicles (vessels, ...). For vessels, the seawater itself is mostly used for cooling. In some cases, chemical coolants are also employed (in closed systems) or they are mixed with seawater cooling.

### PROPOSED SYSTEM

The main aim of the project is to design and analyze cylinder with fins, by changing the thickness of the fins, and geometry of the fin. Analyzation is also done by varying the materials of fins. Present used material for cylinder fin body is Aluminum alloy 204 which has thermal conductivity of 110 - 150 w/mk.

Our aim is to change the material for fin body by analyzing the fin body with other materials and also by changing the thickness.

Geometry of fins - Rectangular, Circular and Curve Shaped

Thickness of fins - 3mm and 2.5mm

Materials - Aluminum Alloy A204, Aluminum Alloy 7075, Magnesium alloy and Beryllium.

Changing distance between fins

### Steps Involved in the Project

1. Modeling
2. Transient Thermal Analysis

For modeling of the fin body, we have used **Pro-Engineer** which is parametric 3D modeling software. For analysis we have used ANSYS, which is FEA software.

### Models of Cylinder Fin Body

#### Original Fin Body

Figure 4: Original Fin Body

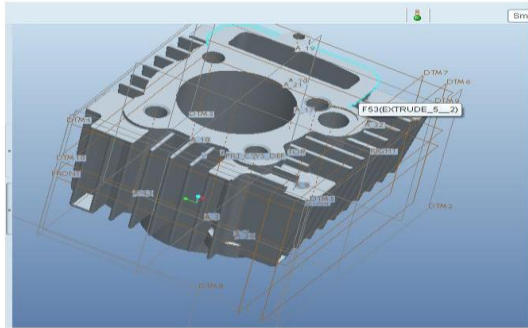

**2d Drawing of Fin Body with 3mm Thickness  
 Rectangular**

Figure 5: Rectangular Shape  
 FIN Body With 3mm Size

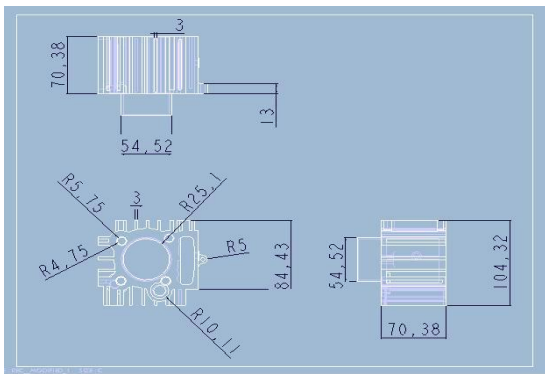

**Circular**

Figure 6: Circular Shape  
 FIN Body With 3mm Size

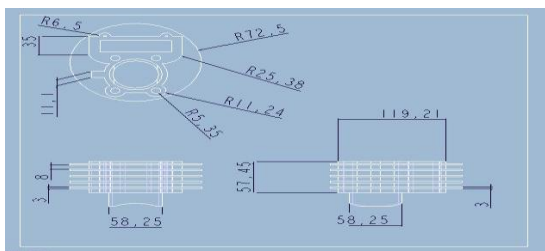

**Curved**

Figure 7: Curve Shape FIN  
 Body With 3mm size

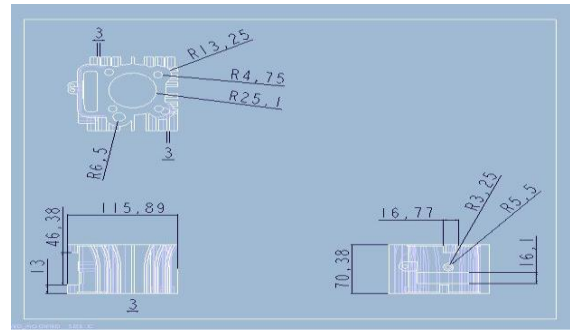

**2d Drawing of Fin Body With 2.5mm  
 Thickness  
 Rectangular**

Figure 8: Rectangular Shape  
 FIN Body With 2.5mm Size

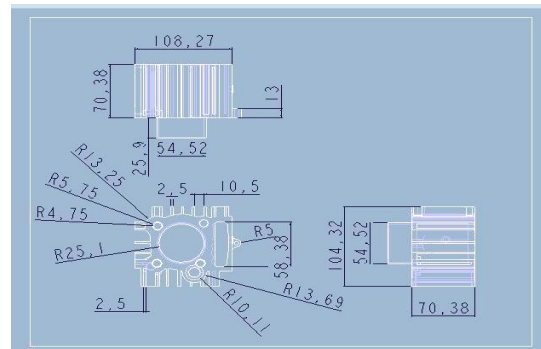

**Circular**

Figure 9: Circular Shape FIN  
 Body With 2.5mm Size

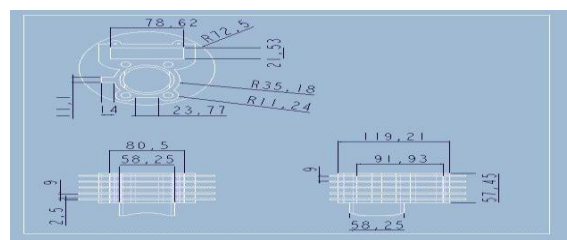

**Curved**

Figure 10: Curve Shape FIN  
Body With 2.5mm Size

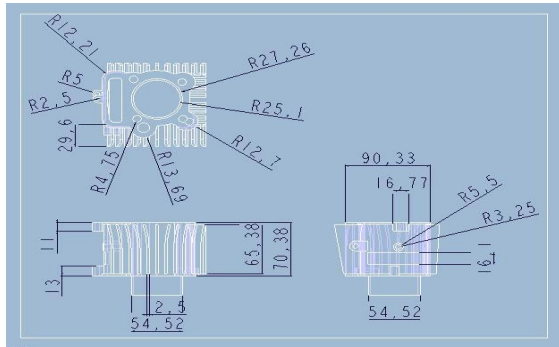

**THERMAL ANALYSIS OF FIN BODY WITH 3MM THICKNESS**

**Material Properties**

Thermal Conductivity - 120 w/mk  
 Specific Heat - 0.963 J/g °C  
 Density - 2.8 g/cc

Figure 11: Rectangle Shaped Aluminum Alloy 204  
Meshed Model With 3mm Thickness

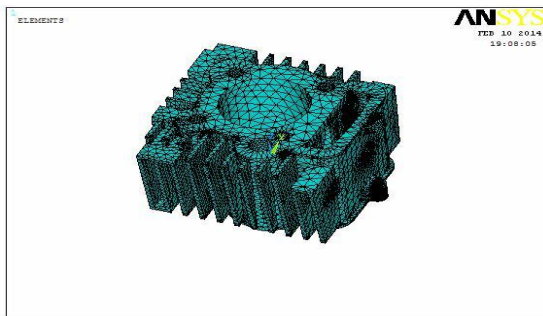

**LOADS**

Internal area=5585K  
 Convections - Remaining areas-Film Co- efficient - 25 W/mmK  
 Bulk Temperature - 313 K

**RESULTS OF RECTANGLE FIN BODY WITH 3MM THICKNESS**

**Aluminum Alloy 204**

**Material Properties**

Thermal Conductivity - 120 w/mk  
 Specific Heat - 0.963 J/g °C  
 Density - 2.8 g/cc  
 Nodal Temperature

Figure 12: Rectangle Shaped Aluminum Alloy 204 at  
Nodal Temperature With 3mm t

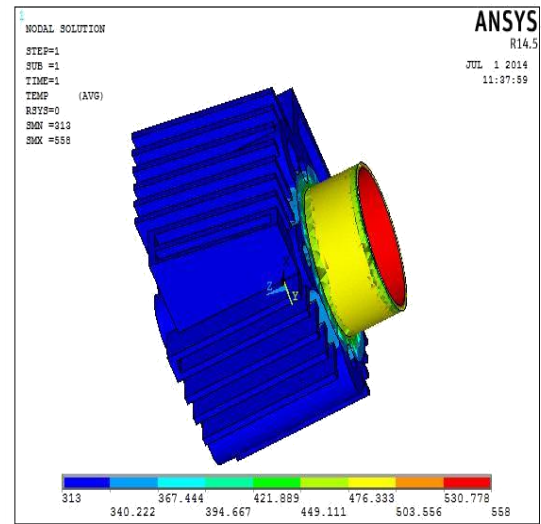

The temperature is maximum inside the cylinder with value of 530.778K and decreasing to outside with 476.333K and is still reducing on the fins.

**Magnesium**

**Material Properties**

Thermal Conductivity - 159 w/mk  
 Specific Heat - 1.45 J/g °C  
 Density - 2.48 g/cc  
 Nodal Temperature

Figure 13: Rectangle Shaped Magnesium at Nodal Temperature With 3mm Thickness

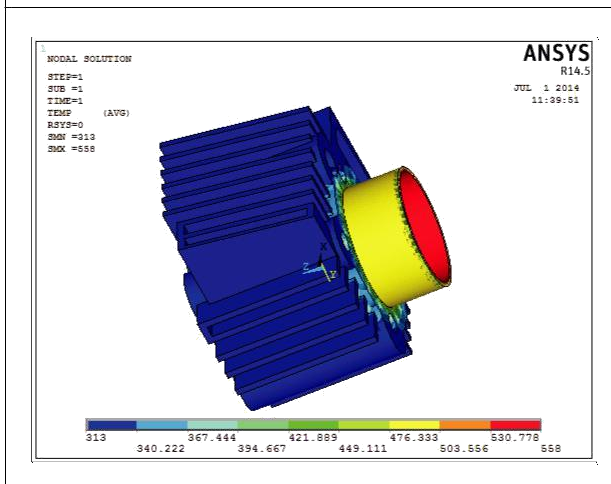

The temperature is maximum inside the cylinder with value of 530.778K and decreasing to outside with 476.333K and is still reducing on the fins.

### Aluminum Alloy 7075

#### Material Properties

Thermal Conductivity - 173 w/mk

Specific Heat - 0.960 J/g °C

Density - 2.7 g/cc

Nodal Temperature

Figure 14: Rectangle Shaped Aluminum Alloy 7075 at Nodal Temperature With 3mm t

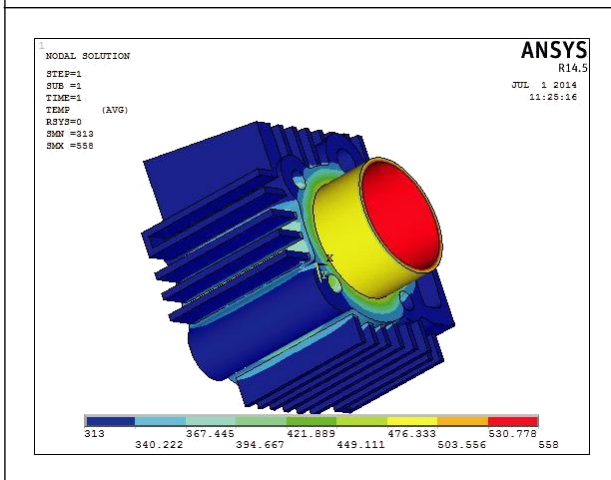

The temperature is maximum inside the cylinder with value of 530.778K and decreasing to outside with 476.333K and is still reducing on the fins.

### Beryllium

#### Material Properties

Thermal Conductivity - 216 w/mk

Specific Heat - 0.927 J/g °C

Density - 1.87 g/cc

Nodal Temperature

Figure 15: Rectangle Shaped Beryllium at Nodal Temperature With 3mm Thickness

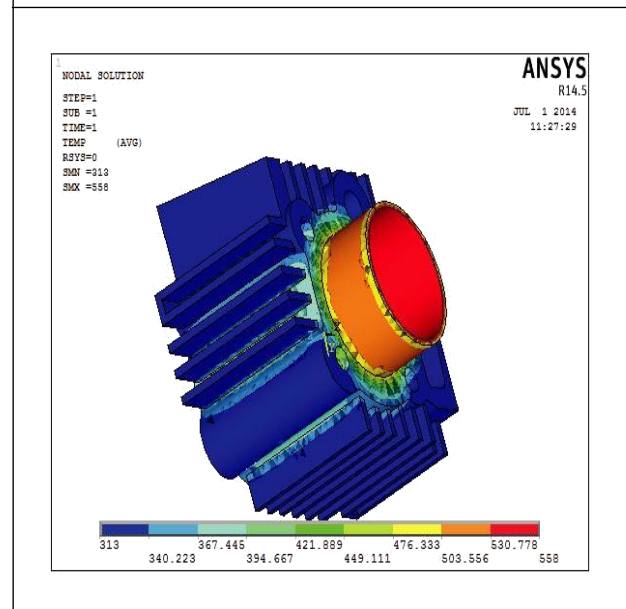

The temperature is maximum inside the cylinder with value of 530.778K and decreasing to outside with 476.333K and is still reducing on the fins.

## RESULTS OF RECTANGLE FIN BODY WITH 2.5MM THICKNESS

### Aluminum Alloy 204

Nodal Temperature

Figure 16: Rectangle Shaped Aluminum Alloy 204 With Nodal Temperature With 2.5mm t

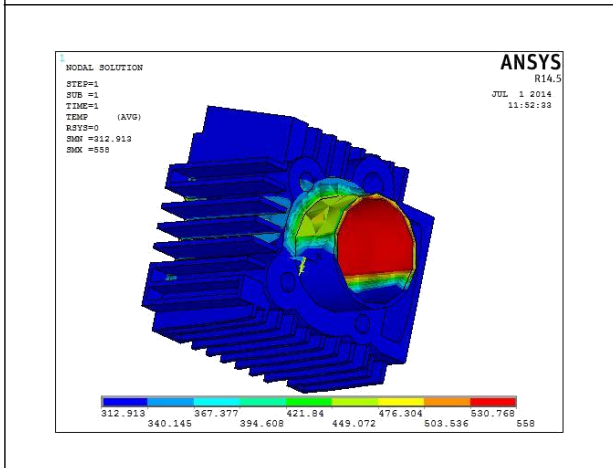

The temperature is maximum inside the cylinder with value of 530.768K and decreasing to outside with 476.304K and is still reducing on the fins.

Magnesium

Nodal Temperature

Figure 17: Rectangle Shaped Magnesium at Nodal Temperature With 2.5mm Thickness

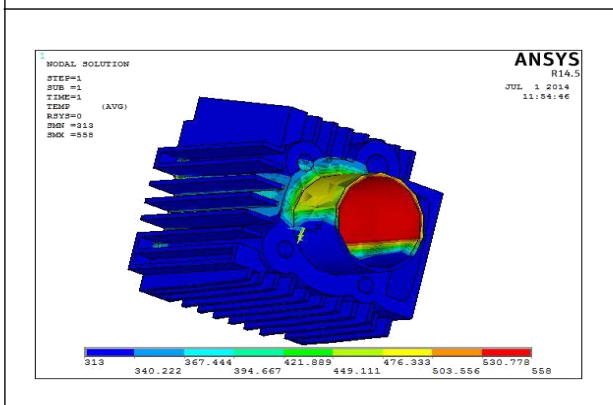

The temperature is maximum inside the cylinder with value of 530.778K and decreasing to outside with 476.333K and is still reducing on the fins.

**Aluminum Alloy 7075**

Nodal Temperature

Figure 18: Rectangle Shaped Aluminum Alloy 7075 at Nodal Temperature With 2.5mm t

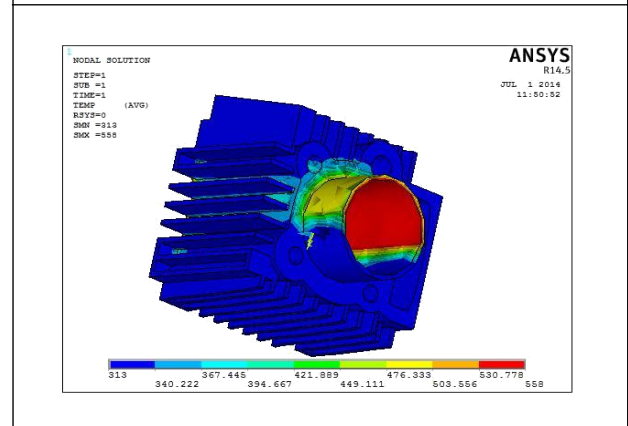

The temperature is maximum inside the cylinder with value of 530.778K and decreasing to outside with 476.333K and is still reducing on the fins.

**Beryllium**

Nodal Temperature

Figure 19: Rectangle Shaped Beryllium at Nodal Temperature With 2.5mm Thickness

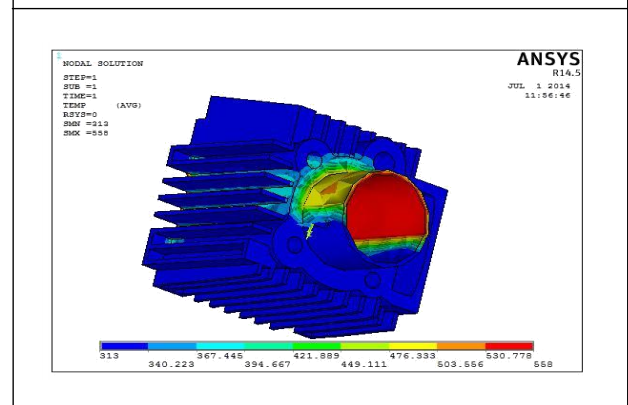

The temperature is maximum inside the cylinder with value of 530.778K and decreasing to outside with 476.333K and is still reducing on the fins.

## RESULTS OF CIRCULAR FIN BODY WITH 3MM THICKNESS

Model Imported From Pro/Engineer

Figure 20: Circular Shaped Aluminum Alloy 204 Model Imported From pro/ Engineer With 3mm

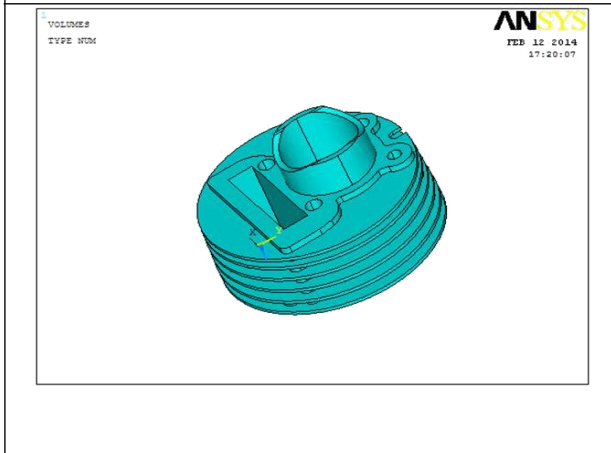
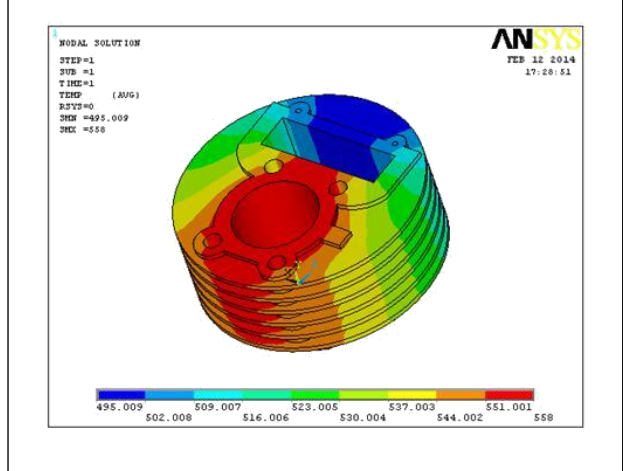
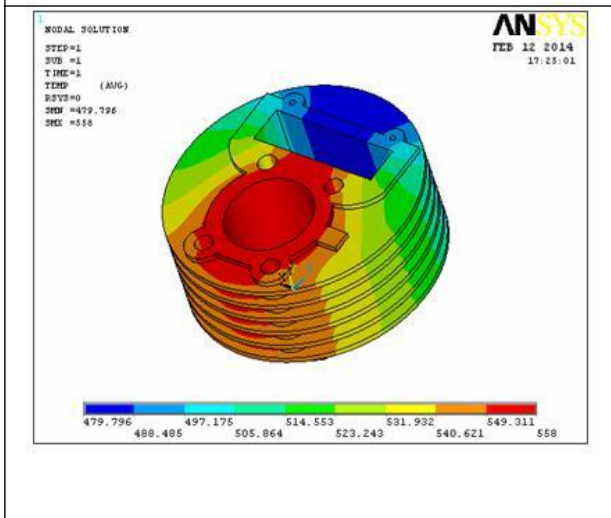

Figure 22: Circular Shaped Magnesium at Nodal Temperature With 3mm Thickness



**Aluminum Alloy 204  
 Nodal Temperature**

Figure 21: Circular Shaped Aluminum Alloy 204 at Nodal Temperature With 3mm Thickness



The temperature is maximum inside the cylinder with value of 549.311K and decreasing to outside with 531.932K and is still reducing on the fins.

**Magnesium  
 Nodal Temperature**

The temperature is maximum inside the cylinder with value of 551.001K and decreasing to outside with 537.003K and is still reducing on the fins.

**Aluminum Alloy 7075  
 Nodal Temperature**

Figure 23: Circular Shaped Aluminum Alloy 7075 at Nodal Temperature With 3mm t

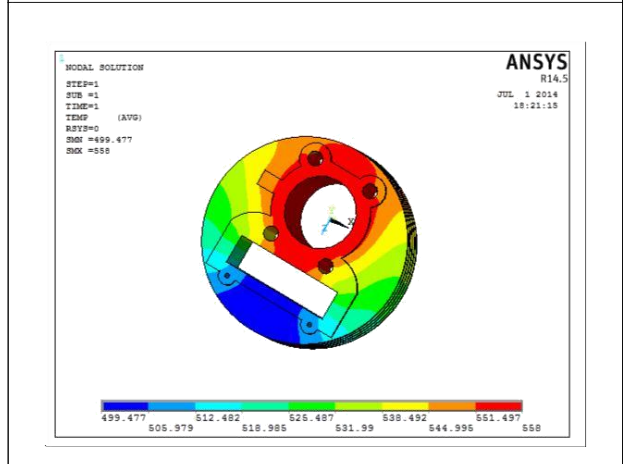

The temperature is maximum inside the cylinder with value of 551.497K and decreasing to outside with 538.492K and is still reducing on the fins.



## Beryllium

### Nodal Temperature

Figure 24: Circular Shaped Beryllium at Nodal Temperature With 3mm Thickness

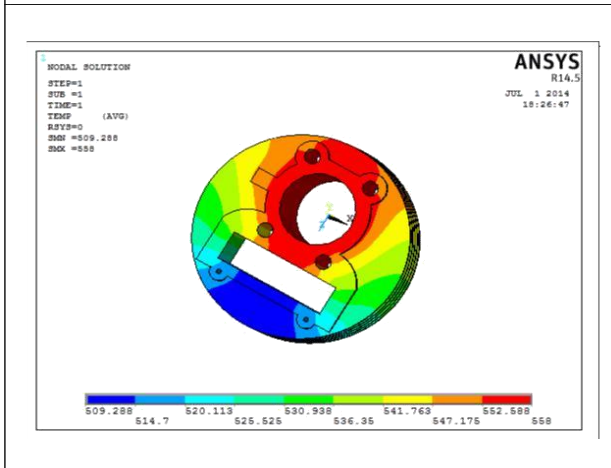

The temperature is maximum inside the cylinder with value of 552.588K and decreasing to outside with 541.763K and is still reducing on the fins.

## RESULTS OF CIRCULAR FIN BODY WITH 2.5MM THICKNESS

### Aluminum Alloy 204

#### Nodal Temperature

Figure 25: Circular Shaped Aluminum Alloy 204 at Nodal Temperature With 2.5mm Thickness

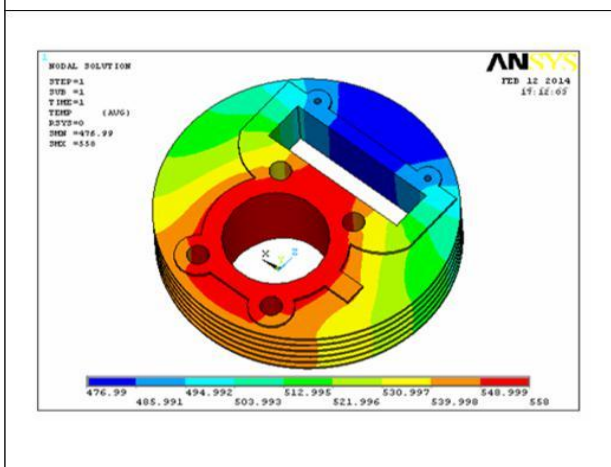

The temperature is maximum inside the cylinder with value of 548.999K and decreasing to outside with 530.997K and is still reducing on the fins.

### Magnesium

#### Nodal Temperature

Figure 26: Circular Shaped Magnesium at Nodal Temperature With 2.5mm Thickness

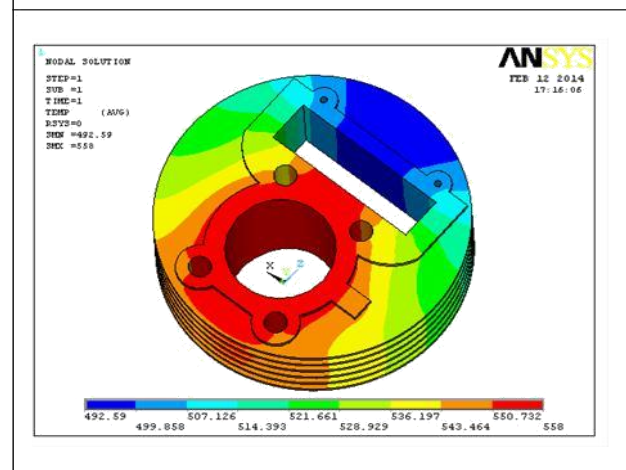

The temperature is maximum inside the cylinder with value of 550.732K and decreasing to outside with 536.197K and is still reducing on the fins.

### Aluminum Alloy 7075

#### Nodal Temperature

Figure 27: Circular shaped Aluminum Alloy 7075 at Nodal Temperature With 2.5mm t

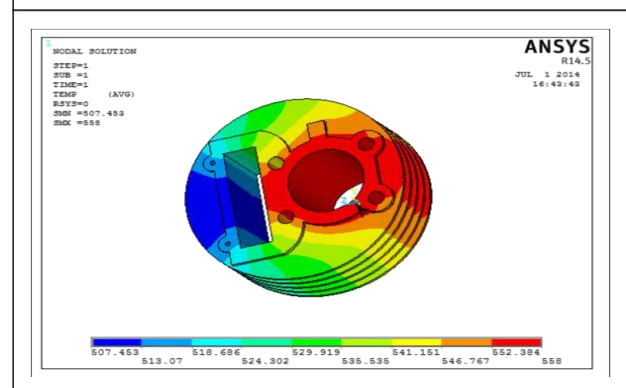

The temperature is maximum inside the cylinder with value of 552.384K and decreasing to outside with 541.151K and is still reducing on the fins.

**Beryllium**

**Nodal Temperature**

Figure 28: Circular Shaped Beryllium at Nodal Temperature With 2.5mm Thickness

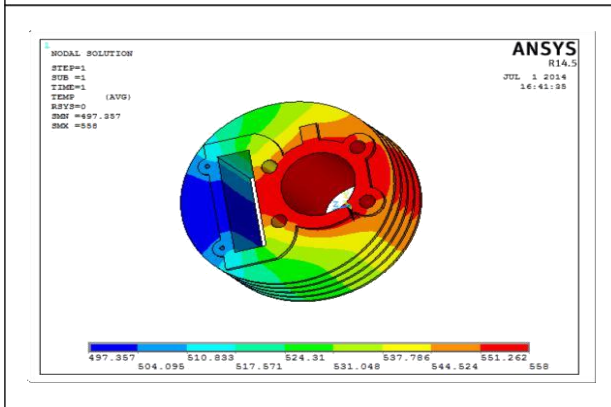

The temperature is maximum inside the cylinder with value of 551.262K and decreasing to outside with 537.786K and is still reducing on the fins.

**RESULTS OF CURVED FIN BODY WITH 3MM THICKNESS**

**Model Imported From Pro/Engineer**

Figure 29: Curve shaped Aluminum Alloy 204 model imported from pro/ engineer with 3mm

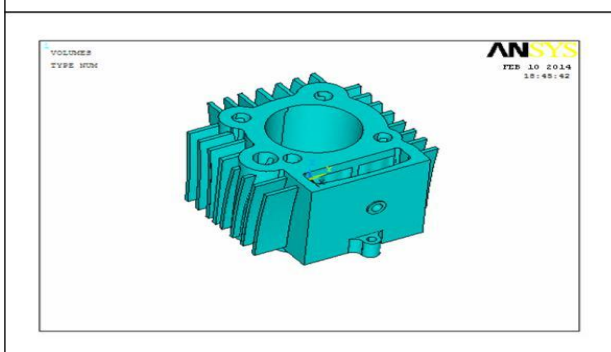

**Aluminum Alloy 204**

**Nodal Temperature**

Figure 30: Curve Shaped Aluminum Alloy 204 at Nodal Temperature With 3mm Thickness

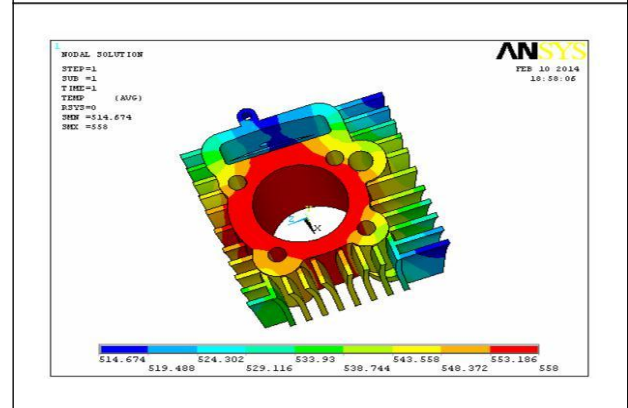

The temperature is maximum inside the cylinder with value of 553.186K and decreasing to outside with 543.558K and is still reducing on the fins.

**Magnesium**

**Nodal Temperature**

Figure 31: Curve Shaped Magnesium at Nodal Temperature With 3mm Thickness

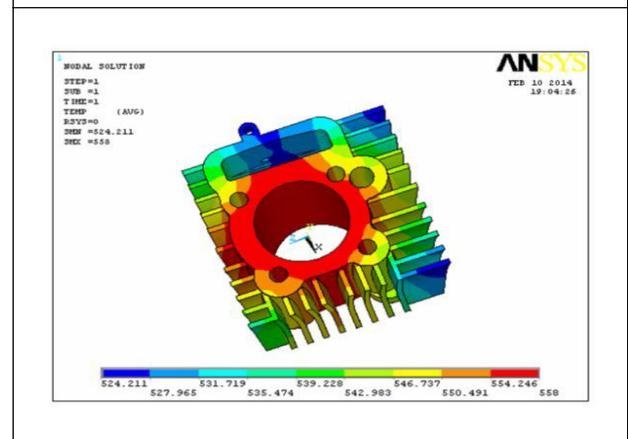

The temperature is maximum inside the cylinder with value of 554.246K and decreasing to outside with 546.737K and is still reducing on the fins.

**Aluminum Alloy 7075**  
**Nodal Temperature**

Figure 32: Curve Shaped Aluminum Alloy 7075 at Nodal Temperature With 3mm Thickness

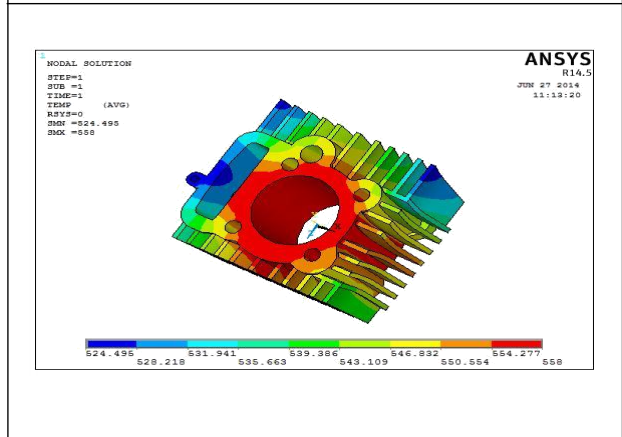

The temperature is maximum inside the cylinder with value of 554.227K and decreasing to outside with 528.218K and is still reducing on the fins.

**Beryllium**  
**Nodal Temperature**

Figure 33: Curve Shaped Beryllium at Nodal Temperature With 3mm Thickness

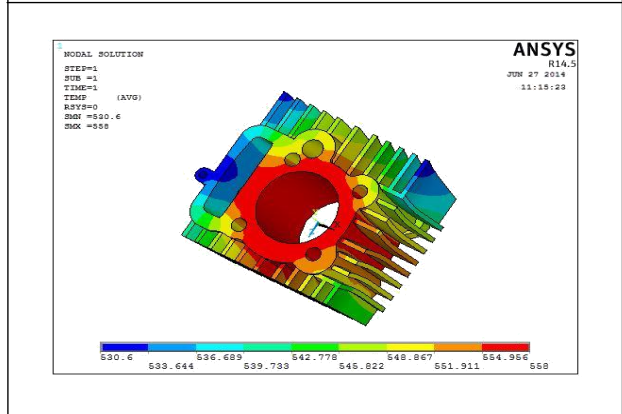

The temperature is maximum inside the cylinder with value of 554.956K and decreasing to outside with 548.867K and is still reducing on the fins.

**RESULTS OF CURVED FIN BODY WITH 2.5MM THICKNESS**

**Aluminum Alloy 204**  
**Nodal Temperature**

Figure 34: Curve Shaped Aluminum Alloy 204 at Nodal Temperature With 2.5mm Thickness

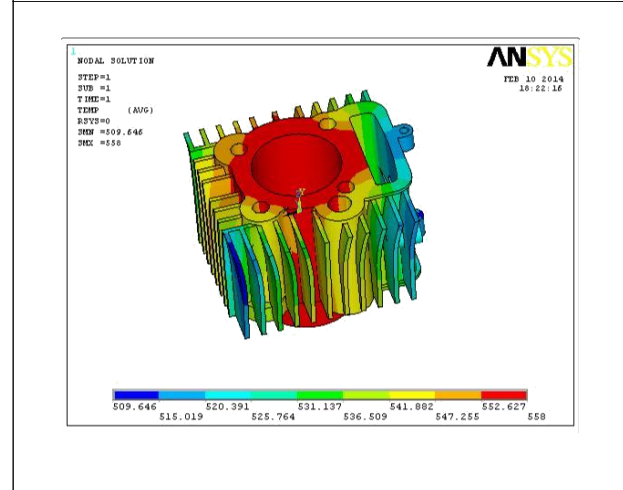

The temperature is maximum inside the cylinder with value of 552.627K and decreasing to outside with 541.882K and is still reducing on the fins.

**Magnesium**  
**Nodal Temperature**

Figure 35: Curve Shaped Magnesium at Nodal Temperature With 2.5mm Thickness

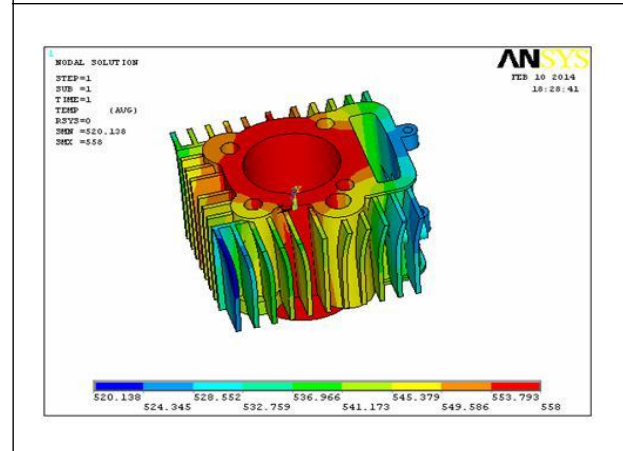

The temperature is maximum inside the cylinder with value of 553.793K and decreasing to outside with 545.379K and is still reducing on the fins.

**Aluminum Alloy 7075**

**Nodal Temperature**

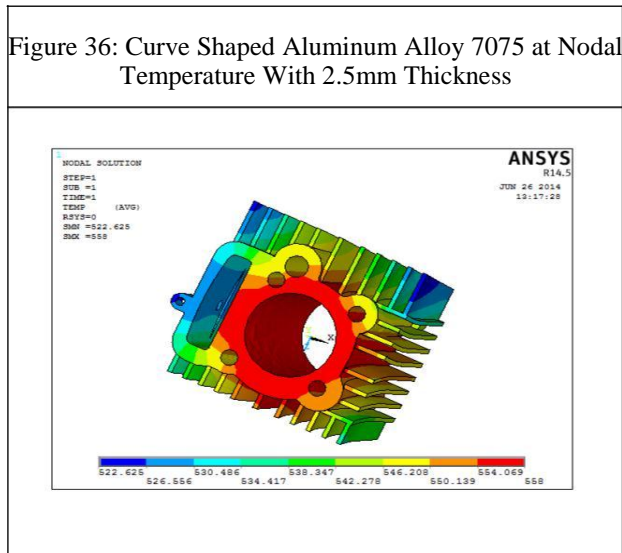

The temperature is maximum inside the cylinder with value of 554.784K and decreasing to outside with 548.351K and is

The temperature is maximum inside the cylinder with value of 554.069K and decreasing to outside with 546.208K and is still reducing on the fins.

**Beryllium**

**Nodal Temperature**

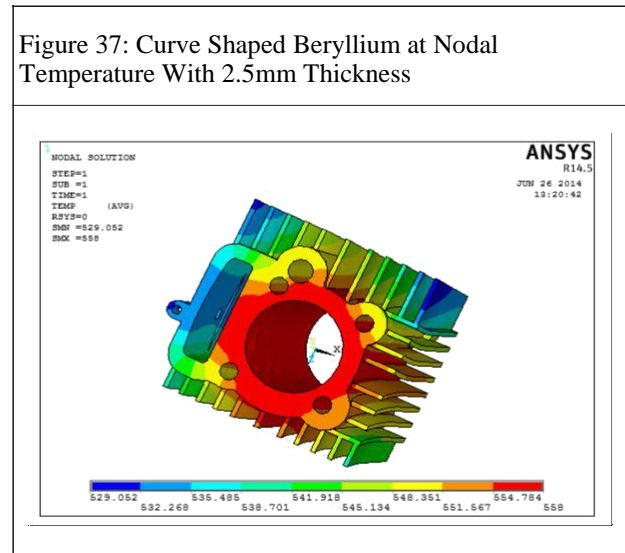

still reducing on the fins.

**EXPERIMENTAL RESULTS**

**Results and Discussions**

Table 1: Results and Discussions

Fin Thickness	Type	Materials	Results		
			Nodal Temperature	Thermal Gradient	Heat Flux
	Curved	Al 7075	558	21.7453	3.76193
		Al 204	558	30.034	3.604
		beryllium	558	17.7891	3.84244
		magnesium	558	2.73671	0.435137
2.5 mm	Circular	Al 7075	558	2.16593	0.467841
		Al 204	558	3.354	0.40253
		beryllium	558	2.62442	0.454025
		magnesium	558	2.663	0.423381
	Rectangular	Al 7075	558	182.998	23.0087
		Al 204	558	170.122	20.4146

2.5 mm		beryllium	558	132.021	28.5166
		magnesium	558	140.767	22.3819
	Curved	Al 7075	558	2.39	0.413
		Al 204	558	3.537	0.424496
		beryllium	558	1.96731	0.42278
		magnesium	558	2.763	0.439357
	Circular	Al 7075	558	2.12	0.366
		Al 204	558	2.99	0.359345
		beryllium	558	1.74111	0.377375
		magnesium	558	2.3772	0.377
	Rectangular	Al 7075	558	70.7334	12.234
		Al 204	558	91.6605	10.9993
		beryllium	558	59.747	12.9054
		magnesium	558	75.254	11.9634

## GRAPHICAL REPRESENTATION

### Thickness of 2.5 mm

#### Curved

Figure 38: Results of Thermal Gradient and Heat Flux of All Materials With Curve Shape and Thickness of 2.5 mm

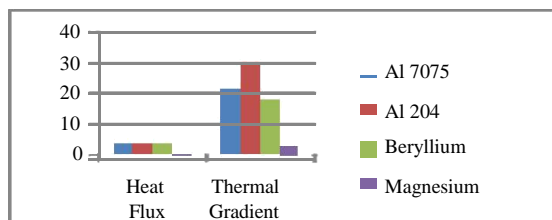

#### Circular

Figure 39: Results of Thermal Gradient and Heat Flux of All Materials With Circular Shape and Thickness of 2.5 mm

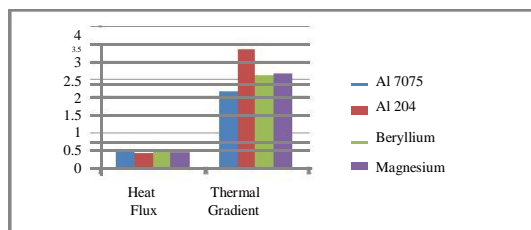

#### Rectangular

Figure 40: Results of Thermal Gradient and Heat Flux of All Materials With Rectangle Shape and Thickness of 2.5 mm

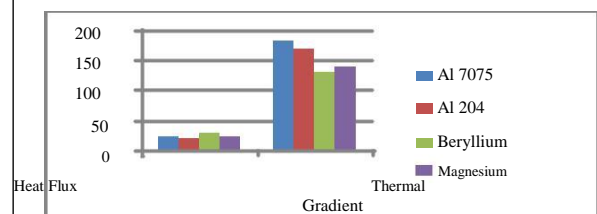

By observing the graphs, the heat flux is more for Beryllium and Aluminum alloy 7075.

### Thickness of 3 mm

#### Curved

Figure 41: Results of Thermal Gradient and Heat Flux of All Materials With Curve Shape and Thickness of 3 mm

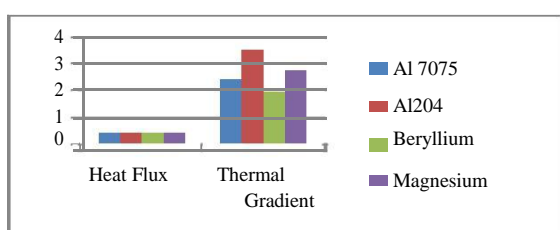

**Circular**

Figure 42: Results of Thermal Gradient and Heat Flux of All Materials With Circular Shape and Thickness of 2.5 mm

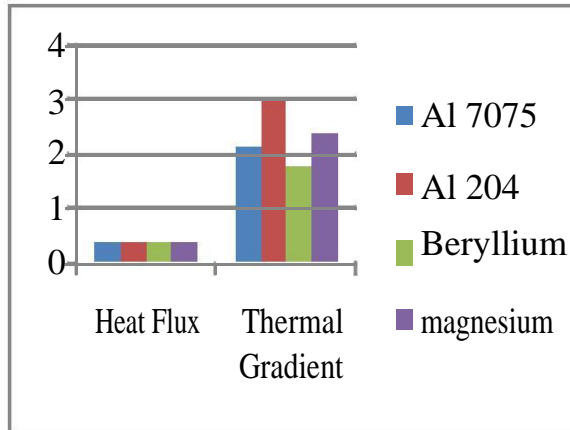

**Rectangular**

Figure 43: Results of Thermal Gradient and Heat Flux of all Materials With Rectangle Shape and Thickness of 2.5 mm

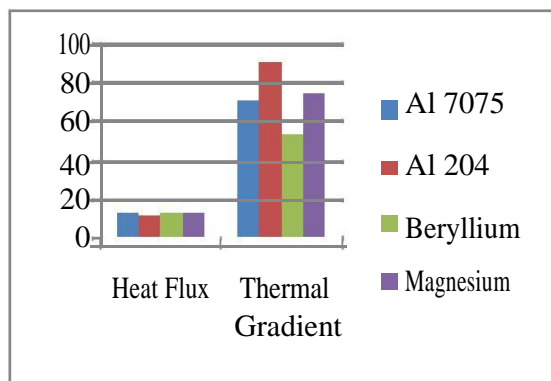

By observing the graphs, the heat flux is more for Beryllium and Aluminum alloy 7075.

**Comparison of Thickness 2.5 mm and 3 mm Curved Thermal Gradient**

Figure 44: Thermal Gradient for Thickness 2.5 mm and 3 mm when curved

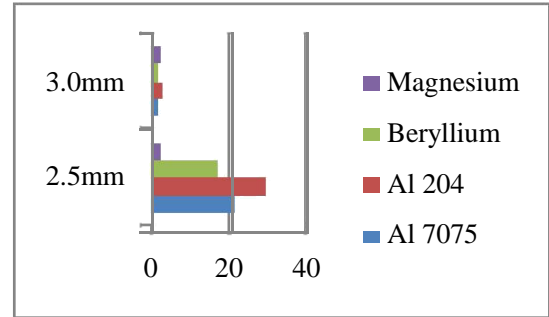

**Thermal Flux**

Figure 45: Thermal Flux for Thickness 2.5 mm and 3 mm when curved

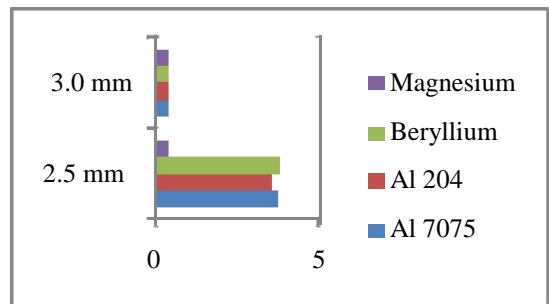

By observing the graphs, the heat flux is more for 2.5mm

**Circular**

**Thermal Gradient**

Figure 46: Thermal Gradient for Thickness 2.5 mm and 3 mm when circle

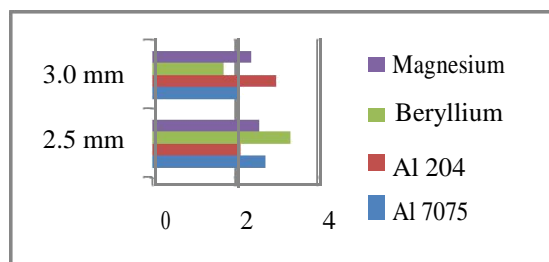

**Thermal Flux**

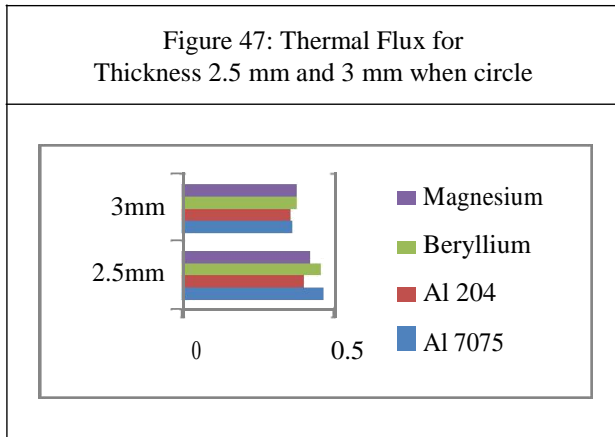

By observing the graphs, the heat flux is more for 2.5mm

**Rectangular**

**Thermal Gradient**

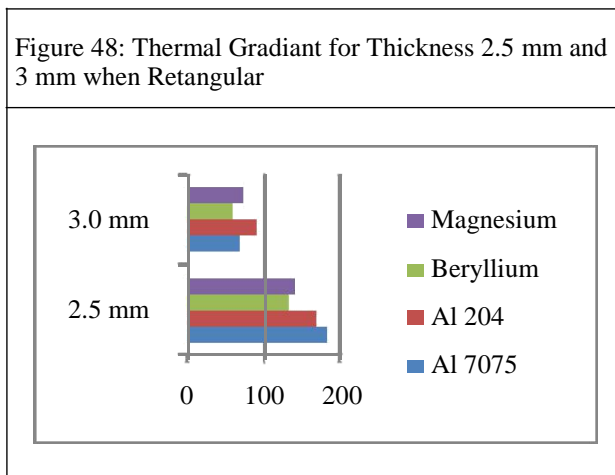

**Thermal Flux**

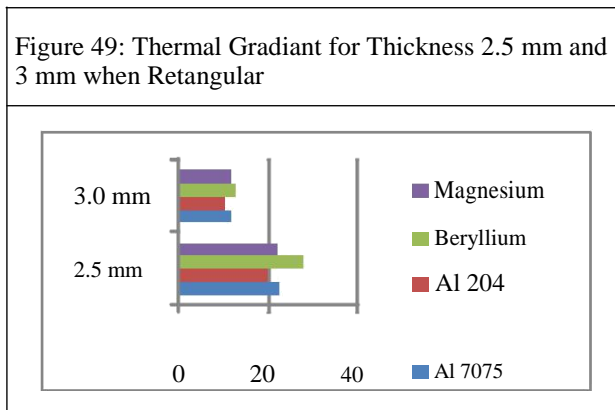

By observing the graphs, the heat flux is more for 2.5mm.

**CONCLUSION & FUTURE SCOPE**

In this thesis, a cylinder fin body for a 150cc motorcycle is modeled using parametric software Pro/Engineer. The original model is changed by changing the thickness of the fins. The thickness of the original model is 3mm, it has been reduced to 2.5mm. By reducing the thickness of the fins, the overall weight is reduced.

Present used material for fin body is Aluminum Alloy 204. In this thesis, three other materials are considered which have more thermal conductivities than Aluminum Alloy

204. The materials are Aluminum alloy 7075, Magnesium Alloy and Beryllium. Thermal analysis is done for all the three materials. The material for the original model is changed by taking the consideration of their densities and thermal conductivity.

By observing the thermal analysis results, thermal flux is more for Beryllium than other materials and also by reducing the thickness of the fin 2.5mm, the heat transfer rate is increased.

The shape of the fin can be modified to improve the heat transfer rate and can be analyzed. The use of Aluminum alloy 6061 as per the manufacturing aspect is to be considered. By changing the thickness of the fin, the total manufacturing cost is extra to prepare the new component.

**REFERENCES**

1. A Dewan, P Patro, I Khan and P Mahanta (2009), "The Effect of Fin Spacing and

Material on the Performance of a Heat Sink With Circular Pin Fins".

2. Biermann A E and Pinkel B (1935), "Heat Transfer from Finned Metal Cylinders in an Air Stream", *NACA Report*, No. 488.
3. Gibson A H (1920), "The Air Cooling of Petrol Engines", *Proceedings of the Institute of Automobile Engineers*, Vol. 14, pp. 243-275.
4. M Kondak and I Shvets (1968), *Thermal Engineering*.
5. Mehul S Patel and N M Vora (2014), "Thermal Analysis of I C Engine Cylinder Fins Array Using CFD", *International Journal of Advance Engineering and Research Development*, Vol. 1, No. 5, pp. 1-11.
6. Nabemoto A (1985), "Heat Transfer on a Fin of Fin Tube", *Bulletin of the Faculty of Engineering, Hiroshima University, (in Japanese)*, Vol. 33, No. 2, pp. 127-136.
7. Nabemoto A and Chiba T (1985), "Flow Over Fin Surfaces of Fin Tubes", *Bulletin of the Faculty of Engineering, Hiroshima University, (in Japanese)*, Vol. 33, No. 2, pp. 117-125.
8. Pai B U, Samaga B S and Mahadevan K (2003), "Experimental Investigation into the Free Air-Cooling of Air-Cooled Cylinders", *SAE Paper*.
9. Pulkit Agarwal, Mayur Shrikhande and P Srinivasan (2011), "Heat Transfer Simulation by CFD from Fins of an Air Cooled Motorcycle Engine under Varying Climatic Conditions", *Proceedings of the World Congress on Engineering*, Vol. III, London, U.K.
10. Thornhill D and May A (1999), "An Experimental Investigation into the Cooling of Finned Metal Cylinders".
11. Thornhill D, Graham A, Cunnigham G, Troxier P and Meyer R (1999), "Free Air Stream", *SAE Paper*.
12. U V Awasarmol and A T Pise (2011), "Pise Experimental Study of Effect of Angle of Inclination of Fins on Natural Convection Heat Transfer Through Permeable Fins", *Proceedings on International Conference on Thermal Energy and Environment*.