

A Review Onenhancement of Power Quality of a Grid Using Dual Voltage Source Inverter

Mr.V.Sunil Kumar & Ms.K.Lakshmi

¹ PG Student, Dept. Of Power Electronics , SKR College Of Engineering & Technology, AP.

² Asst. Professor, Dept. Of Power Electronics, SKR College Of Engineering & Technology, AP.

Abstract: *This paper reveals a dual voltage source inverter(DVSI) design to enhance the energy quality and trustworthiness of the micro grid system. The suggested scheme is made up of two inverters, which permits the micro grid to switch power made by the sent out energy resources (DERs) and to compensate the neighborhood unbalanced and nonlinear weight. The control algorithms are developed predicated on instantaneous symmetrical aspect theory (ISCT) to use DVSI in grid posting and grid injecting settings. The proposed plan has increased dependability, lower bandwidth dependence on the key inverter, less expensive due to decrease in filtration size, and better usage of micro grid ability when using reduced dc-link voltage score for the key inverter. The DVSI is manufactured by these features design a promising option for micro grid providing hypersensitive lots. The control and topology algorithm are validated through comprehensive simulation and experimental results.*

Keywords: DVSI, Instantaneous Symmetrical Aspect Theory(ISCT), DERs.

I.INTRODUCTION

The renewable energy sources are integrated to the network with Distributed Generation(DG). These DG units with co-ordinate control of local generation and storage facilities form a microgrid [1].In microgrid, power from various renewable sources are interfaced with grid and loads using power electronic converters [1],

[2].A microgrid inverter is used to exchange the power from microgrid to the grid and connected load. This microgrid inverter can be operated in

grid sharing mode for supplying a part of local load, and in grid injecting mode for injecting power to main grid. In general the unbalanced load causes low voltage on one leg, power delivery problems and resistance breakdown problems inside the motor or system.If there is a considerable amount of feeder impedance in the distribution systems, the propagation of theharmonic currents distorts the voltage at the point of common coupling (PCC). Industry automation has reached to a very high level of comfortable, plants like auto mobiles manufacturing units, chemical factories, and semiconductor industries required accurate power. The microgrid inverter is used foractive power injection as well as for load compensation; the inverter capacity that can be used for fulfilling the second task is decided by the available instantaneous microgrid real power. Consider an example of a grid-connected PV inverter, the available capacity of the inverter to supply the reactive power becomes less during the maximum solar insolation periods. At the same instant, the reactive power to regulate the PCC voltage is very much needed during this period [2]. It indicates that providing multifunctionalities in a single inverter degrades either the real power injection or the load compensation capabilities. This paper describes a dual voltage source inverter (DVSI) scheme, in which the power generated by the microgrid is injected as real power by the main voltage source inverter (MVSI) and the reactive, harmonic, and unbalanced load compensation is performed by auxiliary voltage source inverter (AVSI). This has an advantage that the rated capacity of MVSI can always be used to inject real power to the grid [4], if sufficient renewable power is available at the dc link. In the DVSI scheme, as total load power is supplied by two inverters,

power losses across the semiconductor switches of each inverter are reduced. This increases its reliability as compared to a single inverter with multifunctional capabilities. Also, smaller size modular inverters can operate at high switching frequencies with a reduced size of interfacing inductor, the filter cost gets reduced. The inverters in the proposed scheme use two separate dc links. Since the auxiliary inverter is supplying zero sequence of load current, a three-phase three-leg inverter topology with a single dc storage capacitor can be used for the main inverter [5]. This in turn reduces the dc-link voltage requirement of the main inverter. Thus, the use of two separate inverters in the proposed DVSI scheme provides increased reliability, better utilization of microgrid power, reduced dc grid voltage rating, less bandwidth requirement of the main inverter, and reduced filter size. Control algorithms are developed by instantaneous symmetrical component theory (ISCT) to operate DVSI in grid-connected mode, while considering nonstiff grid voltage [6]. The extraction of fundamental positive sequence of PCC voltage is done by $dq0$ transformation [9].

II. LITERATURE SURVEY

I. “Microgrid Power Quality Enhancement Using a Three-Phase Four-Wire Grid-Interfacing Compensator (2010)” IEEE Members & Authors :Yunwei Li, D. Mahinda Vilathgamuwa, and Poh Chiang Loh.

This paper presents a three-phase four-wire grid-interfacing power quality compensator for micro grid applications. The compensator is proposed for use with each individual distributed generation (DG) system in the micro grid and consists of two four-phase-leg inverters (a shunt and a series).

[3]. “Grid Interconnection of Renewable Energy Sources at the Distribution Level With Power-Quality

Improvement Features (2011)” IEEE Members & Authors: Mukhtiar Singh, Vinod Khadkikar, Ambrish Chandra and Rajiv K. Varma.

This paper presents a novel control strategy for achieving maximum benefits from these grid-interfacing inverters when installed in 3-phase 4-wire distribution systems. The inverter can thus be utilized as power converter to inject power generated from RES to the grid, and Shunt APF to compensate current unbalance, load current harmonics, load reactive power demand and load neutral current.

3. “ Robust Energy Management for Microgrids With High-Penetration Renewables (2013)” IEEE Members & Authors :Yu Zhang, Nikolaos Gatsis and Georgios B. Giannakis.

Due to its reduced communication overhead and robustness to failures, distributed energy management is of paramount importance in smart grids, especially in microgrids, which feature distributed generation (DG) and distributed storage (DS). The approach involves the actual renewable energy as well as the energy traded with the main grid, so that the supply–demand balance is maintained.

III. DUAL VOLTAGE SOURCE INVERTER

A. System Topology

The proposed DVSI topology is shown in Fig. 1. It consists of a neutral point clamped (NPC) inverter to realize AVSI and a three-leg inverter for MVSI. These are connected to grid at the PCC and supplying a nonlinear and unbalanced load. The function of the AVSI is to compensate the reactive, harmonics, and unbalance components in load currents. Here, load currents in three phases are represented by i_{la} , i_{lb} , and i_{lc} , respectively. Also, $i_g(abc)$, $i_{\mu gm}(abc)$, and $i_{\mu gx}(abc)$ show grid currents, MVSI currents,

and AVSI currents in three phases, respectively. The dc link of the AVSI utilizes a split capacitor topology, with two capacitors C1 and C2. The MVSI delivers the available power at distributed energy resource (DER) to grid. The DER can be a dc source or an ac source with rectifier coupled to dc link. Usually, renewable energy sources like fuel cell and PV generate power at variable low dc voltage, while the variable speed wind turbines generate power at variable ac voltage. Therefore, the power generated from these sources use a power conditioning stage before it is connected to the input of MVSI.

deviation of capacitor voltage from its reference value. Assume that the voltage controller takes n cycles, i.e., nT seconds to act, where T is the system time period. Hence, maximum energy exchange by AVSI during transient will be nST . This energy will be equal to change in the capacitor stored energy. Therefore

$$\frac{1}{2}C_1(V_{dcr}^2 - V_{dc1}^2) = nST \quad (1)$$

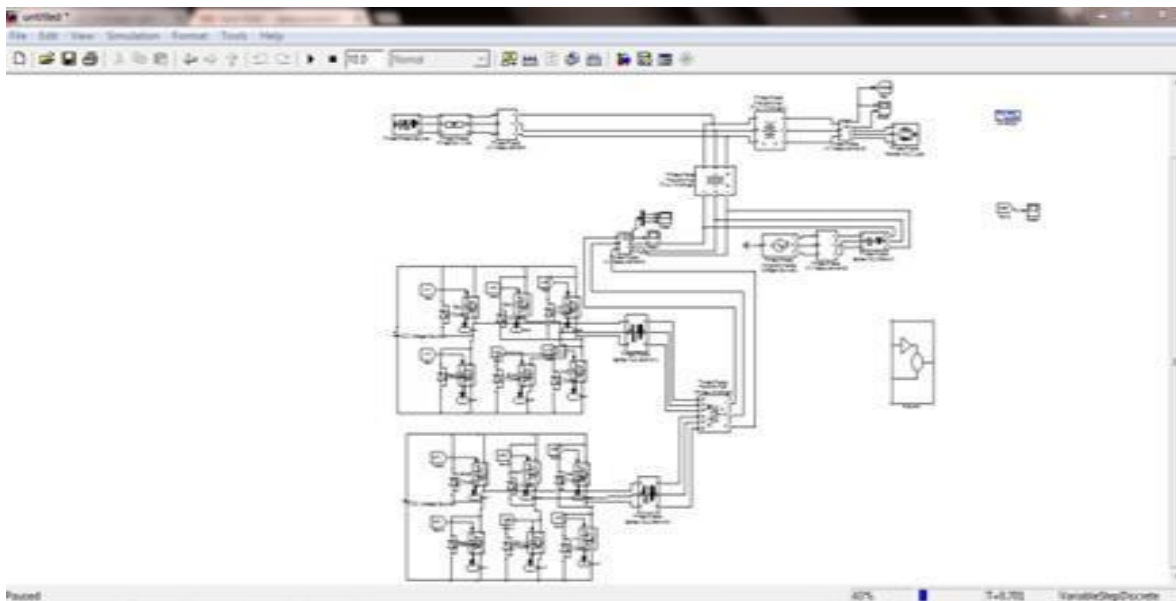

Fig1. Topology of proposed DVSI scheme.

B. Design of DVSI Parameters

AVSI: The important parameters of AVSI like dc-link voltage(V_{dc}), dc storage capacitors (C_1 and C_2), interfacing inductance (L_{fx}), and hysteresis band ($\pm h_x$) are selected based on the design method of split capacitor DSTATCOM topology. The dc-link voltage across each capacitor is taken as 1.6 times the peak of phase voltage. The total dc-link voltage reference (V_{dref}) is found to be 1040 V. Values of dc capacitors of AVSI are chosen based on the change in dc-link voltage during transients. Let total load rating is S kVA. In the worst case, the load power may vary from minimum to maximum, i.e., from 0 to S kVA. AVSI needs to exchange real power during transient to maintain the load power demand. This transfer of real power during the transient will result in

Where V_{dcr} and V_{dc1} are the reference dc voltage and maximum permissible dc voltage across C_1 during transient, respectively. Here, $S = 5$ kVA, $V_{dcr} = 520$ V, $V_{dc1} = 0.8 V_{dcr}$ or $1.2 V_{dcr}$, $n = 1$, and $T = 0.02$ s. Substituting these values in (1), the dclink capacitance (C_1) is calculated to be $2000 \mu F$. Same value of capacitance is selected for C_2 . The interfacing inductance is given by

$$L_{fx} = \frac{1.6 V_m}{4 h_x f_{max}} \quad (2)$$

Assuming a maximum switching frequency (f_{max}) of 10 kHz and hysteresis band (h_x) as 5% of load current (0.5 A), the value of L_{fx} is calculated to be 26 mH. 2) MVSI: The MVSI uses a three-leg inverter topology. Its dc-link voltage is obtained as $1.15 V_{ml}$, where V_{ml} is

the peak value of line voltage. This is calculated to be 648 V. Also, MVSI supplies a balanced sinusoidal current at unity power factor. So, zero sequence switching harmonics will be absent in the output current of MVSI. This reduces the filter requirement for MVSI as compared to AVSI. In this analysis, a filter inductance (L_{fm}) of 5 mH is used.

C. Advantages of the DVSI Scheme

The various advantages of the proposed DVSI scheme over a single inverter scheme with multifunctional capabilities are discussed here as follows:

- 1. Increased Reliability:** DVSI
- 4. Reduction in Filter Size:** In DVSI scheme, the currents supplied by each inverter is reduced and hence the current rating of individual filter inductor reduces. This reduction in current rating reduces the filter size. Also, in this scheme, hysteresis current control is used to track the inverter reference currents. As given in (2), the filter inductance is decided by the inverter switching frequency. Since the lower current rated semiconductor device can be switched at higher switching frequency, the inductance of the filter can be lowered. This decrease in inductance further reduces the filter size.
- 5. Improved Flexibility:** Both the inverters are fed from separate dc links which allow them to operate independently, thus increasing the flexibility of the system. For instance, if the dc link of the main inverter is disconnected from the system, the load compensation capability of the auxiliary inverter can still be utilized.
- 6. Better Utilization of Microgrid Power:** DVSI scheme helps to utilize full capacity of MVSI to transfer the entire power generated by DG units as real power to ac bus, as there is AVSI for harmonic and reactive power compensation. This increases the active power injection capability of DGs in micro grid.
- 7. Reduced DC-Link Voltage Rating:** Since, MVSI is not delivering zero sequence load current components, a single capacitor three-leg VSI topology can be used. Therefore, the dc link voltage rating of MVSI is reduced

approximately by 38%, as compared to a single inverter system with split capacitor VSI topology

D. GRID-TIE Inverter

A grid-tie inverter is a power inverter that converts direct current (DC) electricity into alternating current (AC) with an ability to synchronize to interface with a utility line. Its applications are converting DC sources such as solar panels or small wind turbines into AC for tying with the grid. Residences and businesses that have a grid-tied electrical system are permitted in many countries to sell their energy to the utility grid. Electricity delivered to the grid can be compensated in several ways. "Net metering" is where the entity that owns the renewable energy power source receives compensation from the utility for its net outflow of power. So for example, if during a given month a power system feeds 500 kilowatt-hours into the grid and uses 100 kilowatt-hours from the grid, it would receive compensation for 400 kilowatt-hours. In the US, net metering policies vary by jurisdiction.

E. Typical Operation

Inverters take DC power and invert it to AC power so it can be fed into the electric utility company grid. The grid tie inverter (GTI) must synchronize its frequency with that of the grid (e.g. 50 or 60 Hz) using a local oscillator and limit the voltage to no higher than the grid voltage. A high-quality modern GTI has a fixed unity power factor, which means its output voltage and current are perfectly lined up, and its phase angle is within 1 degree of the AC power grid. The inverter has an on-board computer which senses the current AC grid waveform, and outputs a voltage to correspond with the grid. However, supplying reactive power to the grid might be necessary to keep the voltage in the local grid inside allowed limitations. Otherwise, in a grid segment with considerable power from renewable sources, voltage levels might rise too much at times of high production, i.e. around noon. Grid-tie inverters are also designed to quickly disconnect from the grid if the utility grid goes down. This is an NEC requirement that ensures that in the event of a blackout, the grid tie inverter will

shut down to prevent the energy it transfers from harming any line workers who are sent to fix the power grid. Properly configured, a grid tie inverter enables a home owner to use an alternative power generation system like solar or wind power without extensive rewiring and without batteries. If the alternative power being produced is insufficient, the deficit will be sourced from the electricity grid.

F. Technology

Technologies available to grid-tie inverters include newer high-frequency transformers, conventional low-frequency transformers, or they may operate without transformers altogether. Instead of converting direct current directly to 120 or 240 volts AC, high-frequency transformers employ a computerized multi-step process that involves converting the power to high-frequency AC and then back to DC and then to the final AC output voltage. Transformer

less inverters, lighter are more efficient than their counterparts with transformers, are popular in Europe. However, transformer less inverters have been slow to enter the US market over concerns that transformer less electrical systems could feed into the public utility grid without galvanic isolation between the DC and AC circuits that could allow the passage of dangerous DC faults to be transmitted to the AC side.^[4] However, since 2005, the NFPA's NEC allows transformer less (or non-galvanically) inverters by removing the requirement that all solar electric systems be negative grounded and specifying new safety requirements. The VDE 0126-1-1 and IEC 6210 also have been amended to allow and define the safety mechanisms needed for such systems. Primarily, residual or ground current detection is used to detect possible fault conditions. Also isolation tests are performed to ensure DC to AC separation.



Fig2. Inside of a SWEA 250W Transformer-based grid-tie inverter.

IV. EXPERIMENTAL RESULT

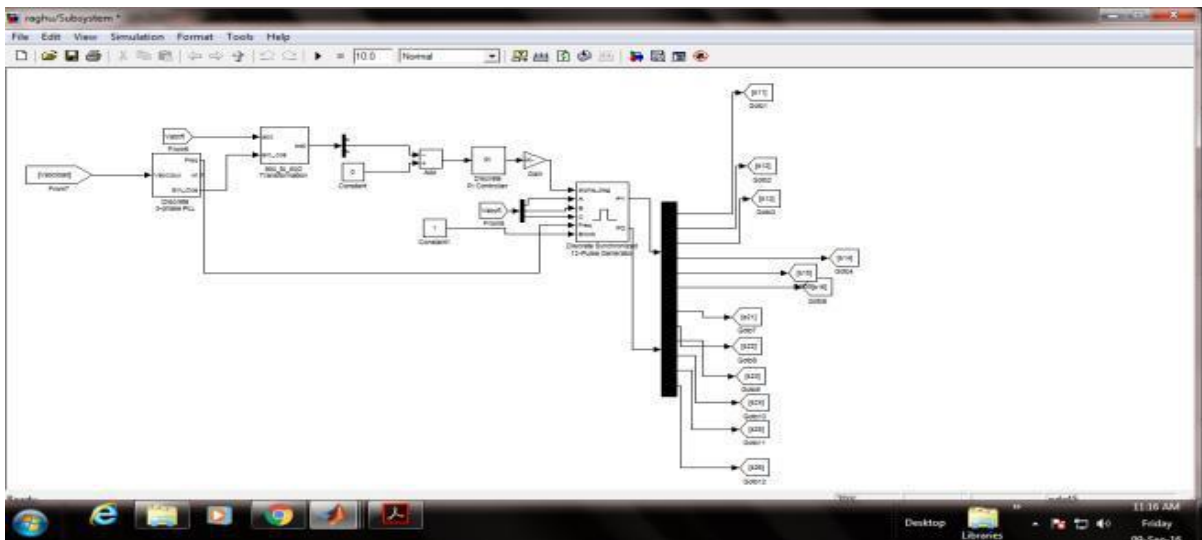

Fig3. Simulation diagram showing the control strategy of proposed D VSI scheme.

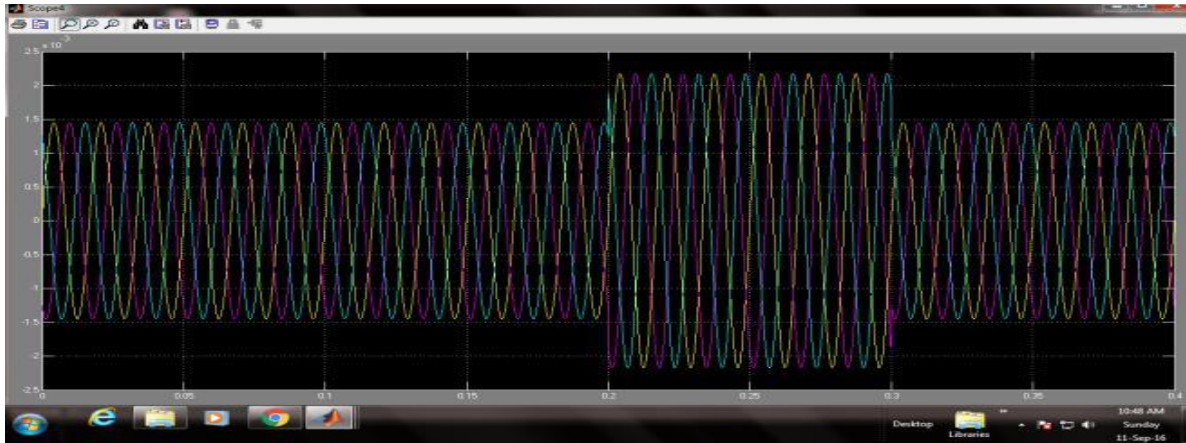

Fig4. Voltage swell during non linear load parallel to the dual inverter connected load.

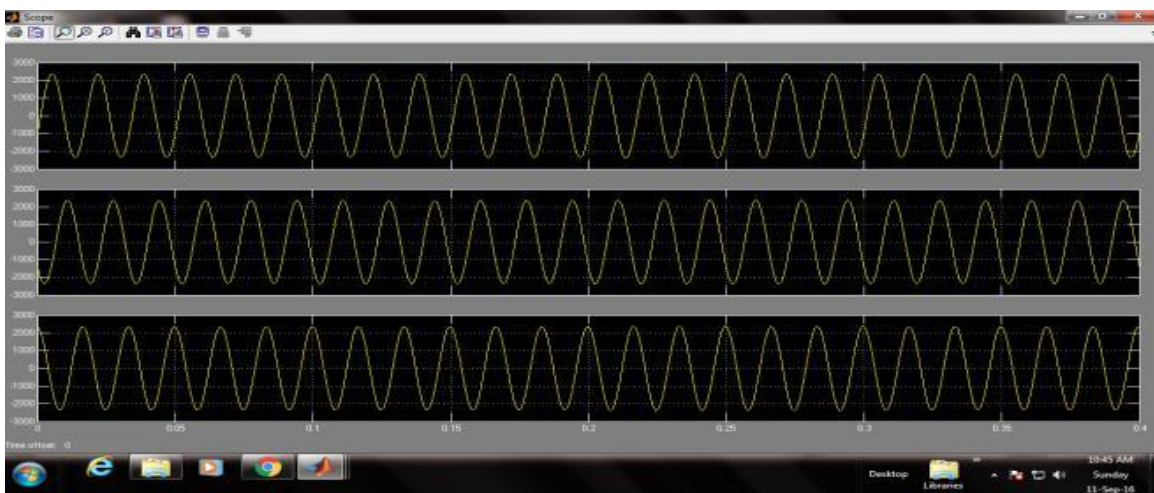

Fig5. 3-phase voltages of dual inverter fed line.

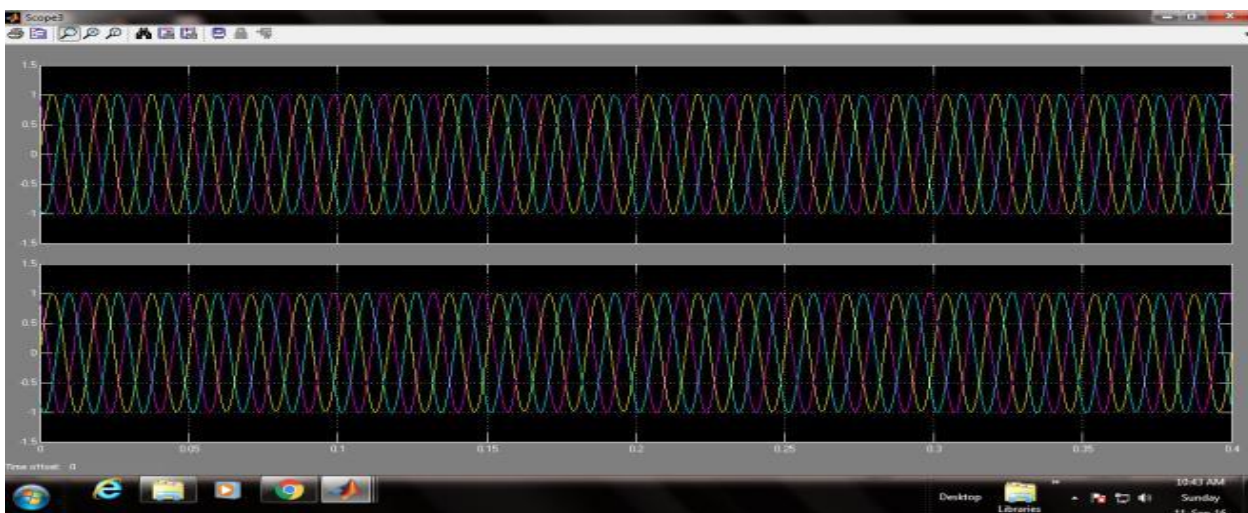

Fig6. 3-phase load voltages and currents.

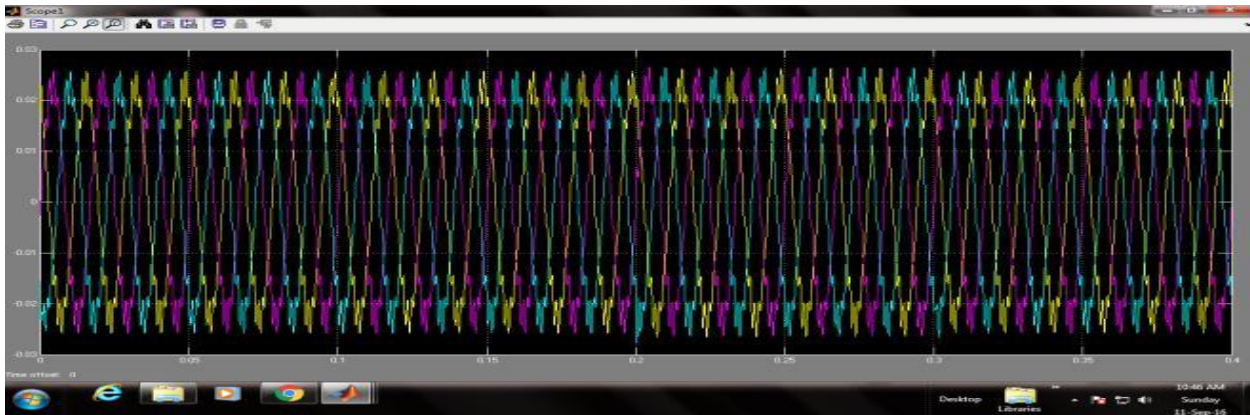

Fig7. 3-phase currents of dual fed line.

V.CONCLUSION

A DVSI scheme is proposed for microgrid systems with enhanced power quality. Control algorithms are developed to generate reference currents for DVSI using ISCT. The proposed scheme has the capability to exchange power from distributed generators (DGs) and also to compensate the local unbalanced and nonlinear load. The performance of the proposed scheme has been validated through simulation studies. As compared to a single inverter with multifunctional capabilities, a DVSI has many advantages such as, increased reliability, lower cost due to the reduction in filter size, and more utilization of inverter capacity to inject real power from DGs to microgrid. Moreover, the use of three-phase, three wire topology for the main inverter reduces the dc-link voltage requirement. Thus, a DVSI scheme is a suitable interfacing option for microgrid supplying sensitive loads.

REFERENCES

- [1]. A.Naveen Kumar, A.Dheepanchakkavarthy, Prof.Jebasalma, "A Modern Approach of Three Phase Four Wire DVSI for Pq Improvement using SRF Theory", IJRET, ISSN:2278-0181, Vol.5, Issue 03, March-2016.
- [2]. M.V.Manoj Kumar, Mahesh.K.Mishra and Chandan Kumar, "A Grid-connected Dual Voltage Source Inverter With Power Quality Improvement Features," IEEE Transactions on Sustainable Energy, Vol. 6, No.2, pp. 482-490, April 2015.
- [3]. Nikhila Emerson, S.Srinivasan, "Enhancement of Power Quality in Distributed Generation Resources Using ANT COLONY Optimization", IJAICT Vol.1, Issue 11, ISSN 2348-9928, March 2015.
- [4]. KavaliHemadri, V.VeeraNagi Reddy, "Power Quality Enhancement in Distribution System Using ANN based DSTATCOM", IJSTER, Vol.4, Issue 5, May 2015.
- [5]. J.Seeralan, V.Karthikeyan, "A Grid Power Quality Enhancement by Dual Voltage Source Inverter", International Research Journal in Advanced Engineering and Technology(IRJAET), Vol.1, Issue 4, pp.365-371, November 2015.
- [6]. N. R. Tummuru, M. K. Mishra, and S. Srinivas, "Multifunctional VSC controlled microgrid using instantaneous symmetrical components theory," IEEE Trans. Sustain. Energy, vol. 5, no. 1, pp. 313–322, January 2014.
- [7]. J.Guerro, P.C.Loh, T.-L Lee, and M.Chandorkar, "Advanced Control Architecture for intelligent Microgrids- Part II: Power quality, energy storage, and ac/dc Microgrids", IEEE Trans. Ind.Electron., Vol.60, No.4, pp.1263 -1270, December 2013.
- [8]. A.Kahrobaeian and Y.R.Mohamed, "Interactive distributed generation interface for flexible microgrid operation in smart distribution systems", IEEE Trans. Sustain. Energy, Vol. 3, No.2, pp.295-305, April 2012.
- [9]. Y.Zhang, N.Gatsis, and G.Giannakis, "Robust energy management for Microgrids with high-penetration renewables", IEEE Trans. Sustain. Energy, Vol.4, No.4, pp.944-953, October 2013.

[10]. M.Schonardie, R.Coelho, R.Schweitzer, and D.Martins, “Control of the active and reactive power using dq0 transformation in a three-phase grid-connected PV system”, in Proc.IEEEInt.Symp.Ind.Electron., pp.264-269, May 2012.

Author’s Profile



Mr.V.SUNIL KUMAR

received B.Tech in Electrical and Electronics Engineering from Priyadarshini college of Engineering and Technology, Kanuparthipadu, Nellore affiliated to the Jawaharlal Nehru technological university Anantapur in 2015, and pursuing M. Tech in Power Electronics from SKR College of Engineering and Technology, Kondurusatram(v), Manubolu (M), affiliated to the Jawaharlal Nehru technological university Anantapur in (2015-2017) , respectively.



Ms.K.Lakshmi Has Received Her B.Tech In EEE In 2013 And M.Tech PG In Electrical Power Engineering from JNTU Ananthapur In 2016. She Has Guided 4 P.G Students And 8

U.G Students. Her Research Included Electrical Power Engineering At Present she Is Working As Asst Professor In SKR Engineering College, Kondurusatram (v), Manubolu (M), SPSR Nellore, AP. India.. she Is Highly Passionate And Enthusiastic About H Teaching And Believes That Inspiring Students To Give Of Her Best In Order To Discover What She Already Knows Is Better Than Simply Teaching.