

Performance Improvement of Wireless communication System of DSCDMA with Rake Receiver

¹Mr. Khaire Ganesh B. & ²Prof. R.B. Sonawane

Dept.ofElectronics AVCOE, Sangamner India, Affiliated to university of Pune.

gnskhr@gmail.com ; rbsonawane2007@gmail.com

Abstract—

This paper develops a performance of DS-CDMA wireless communication system over a multipath fading channel is examined. The analysis is related to DS-CDMA with Rake Receiver. BER is a strategic parameter that is used in evaluating systems that transfer digital data from one place to another. Rake receiver having many fingers also called sub-receiver. In which received signal get multiplied with time delayedforms of locally generated code sequence.To takings advantage of the SNR and minimize the BER the CDMA Rake receiver is used. Using rake receiver we have better signal than without rake receiver. It is used in CDMA as effectual multipath signal reception, where several receptors are able to reconstruct the same signal with different time codes, amplitude & phase. A Fading Channel is well-known as communications channel. In this paper different fading systems also briefly explained. BER simulation is done using MATLAB as software tool.

IndexTerms—

BER (Bit Error Rate); DS-CDMA (DirectSequence-CDMA); Error Control Coding; Fading; Multipath Fading Channels; Rake Receiver

1. INTRODUCTION

Many modern communication systems, like wirelesscellular systems, operate in environments that areinterference and bandwidth limited, where propagationcharacteristics are more problematic

and multipath-inducedfading and shadowing are a common problem. Rake receiver consists of multiple fingers or correlators, in which the receive signal multiplied with time-delayedforms of a nearbyformed code series. To maximize the SNR and minimize the BER the CDMA Rake receiver is used. In a wireless mobile communication system, a signal can travel from transmitter (TX) to receiver (RX) over multiple paths; this phenomenon is referred to as multipath propagation. There are many systems that define the method of fading either small or large scale. Out of these replicas, Rayleigh fading, Rician fading and Nakagami fading replicas are most widely used. It is important to calculate the performance of wireless devices by considering the transmission characteristics, wireless channel parameters and device structure. The performance of data transmission is well calculated by observing BER [3] at the receiver. In wireless channels, several models have been proposed and investigated to calculate SNR. Nowadays We are using three modeling techniques which depends on characteristics of signal.The techniques are Additive White Gaussian Noise (AWGN), Rayleigh and Rician models. The signal is found and recover by employing several models of the received signal. So, structure with multilink we have considered. The physical layer is used particular modulation technique.

BER is mainly related to measure the overall system performance of wireless communication system which calculates the dependability of communication system [4].

Error Control coding is a technique where redundancy is added to the original bit sequence to increase the reliability of the communication [4].

Rake Receiver is used in CDMA cellular systems which can combine multipath mechanism, which are time delayed forms of the original signal transmission. This combining is done to improve SNR at receiver [1], [2].

2. WIRELESS CHANNEL MODELING

Wireless communication is one of the majority lived areas of today's life. Wireless channels have to be simulated accurately and it is very important for the implementation of the system. Performance of system totally depends on accuracy of design and simulation results. Multipath phenomenon is important also to consider that loss of signals. Fading is another major and challenging issue that leads us to the design fading models accurately depends upon different environments and conditions. Even though no model can 'accurately' describe an environment, they struggle to obtain as much exactness as possible. The better fading model is that it can be compensated with other signal. At receiver end we get totally noise free signal with high voice quality.

FADING AND MULTIPATH

Carrier-modulated communication signal experiences distortion over certain propagation media. Fading occurs due to multipath propagation referred to as multipath induced fading. Multipath means that more than one signal is received at the receiving antenna. Causes of multipath include reflections, refractions, scattering & Doppler shift. Fading is mainly due to distortions at the receiving end. The phenomenon of reflection, diffraction and scattering all give rise to additional radio propagation paths ahead of the direct optical Line Of Sight (LOS) path between the radio transmitter and receiver [14].

3. RAKE RECEIVER

The block diagram of DS-CDMA with Rake Receiver is as shown in figure 2. In a multipath channel, delayed reflections interfere with the direct signal in a DS-CDMA. This can be detected by a rake receiver. A RAKE receiver uses several baseband correlators to individually multipath components. The correlators or fingers are combined to increase SNR (Signal To Noise Ratio). A RAKE receiver, used particularly in CDMA systems that combine multipath signals, which are time-delayed forms of the transmitted original signal. At the transmitting end many signals are transmitted because of reflections it causes each signal having different amplitude, phase and delays. At the receiving end a RAKE receiver is used to combine multipath signals & recover them. This combination is done to increase the performance of the system i.e. to increase signal to noise ratio (SNR) at the receiver. A RAKE receiver efforts to accumulate the time shifted forms of the unique signal through provided that a separate sub-receiver for each of the multipath signals those are coming from transmitting side. It uses a multiple path diversity principle. It is similar to a rake that degenerates the energy from the multiple signals which are propagated.

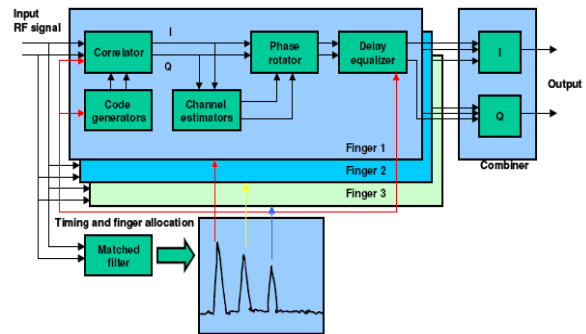

Figure 1: Block diagram of a RAKE receiver

A rake receiver consists of multiple fingers or correlators or sub receivers, in which the received signal gets multiplied with time-delayed forms of a temporary generated code sequence. The main function of a rake receiver is that to separate the signals such that each finger only achieves signals coming in over a recovered path.

i.e. main component of signal. The spread code have to be selected with a very small autocorrelation value because for any non-zero time counterbalance that avoids crosstalk between fingers or sub receivers. It does not determine a full periodic autocorrelation which shows that the crosstalk between signals in dissimilar fingers, but rather than this two partial correlations have to be considered with influences from two uninterrupted bits or symbols. It is necessary to find sequence that have at least satisfactory partial correlation values, but the cross talk due to non periodic correlations leftoversconsiderablyadditional difficult. The rake receiver is designed to optimally detect as DS-CDMA signal transmitted over dispersive multipath channel.

Like a garden rake, the rake receiver collects the energy received from the different delayed propagation paths. According to the principle of maximum ratio, the SNR at the output side or receiver end is the sum of SNR's in the distinct divisions, delivered that, We assume that only AWGN channel is present and codes with time offset are truly orthogonal.

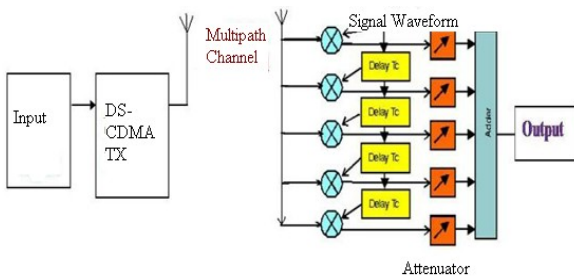

Fig. 2. Simple Block Diagram of DS-CDMA with RAKE Receiver.

4. FADING CHANNELS

A Fading Channel also named as communications channel which has to go through different fading phenomenon's, during communication communication channels has to go through many different distortions i.e. fading. In today's world surroundings, the many propagation effects combine together and multipath is created by these communication channels. All received signal is added at the receiver. Some signal have direct path so these

signal get subtracted. In wireless communication channel, transmitted signal can travel transmitter mobile station to receiver station over many paths. There are two types of fading slow fading / fast fading and frequency - selective

4.1 TYPES OF SMALL SCALE FADING

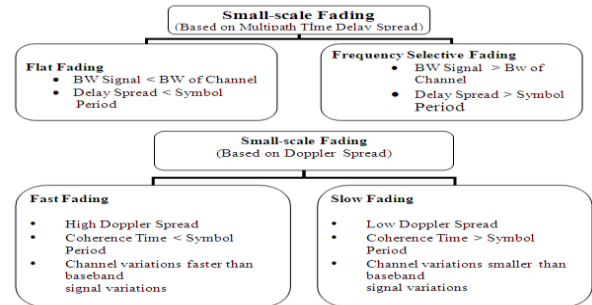

Figure 3. Types of small scale fading

4.1.1 Rayleigh fading model

The Rayleigh fading is primarily caused by multipath reception [6]. Rayleigh fading is a statistical model for the effect of a propagation environment on a radio signal. It is a reasonable model for troposphere and ionospheres' signal propagation as well as the effect of heavily built-up urban environments on radio signals. Rayleigh fading [7] is most applicable when there is no line of sight between the transmitter and receiver.

4.1.2 Rician fading model

The Rician fading model [6] is similar to the Rayleigh fading model, except that in Rician fading, a strong dominant component is present. This dominant component is a stationary (non fading) signal and is commonly known as the LOS (Line of Sight Component).

4.2.3 Additive White Gaussian Noise Model

The simplest radio environment in which a wireless communications system or a local positioning system or proximity detector based on Time of flight will have to operate is the AWGN [4] environment. AWGN is the commonly used to transmit signal while signal travel from the channel and simulate background noise of channel. The mathematical expression in received signal $r(t) = s(t) + n(t)$ that passed through the AWGN channel

where $s(t)$ is transmitted signal and $n(t)$ is background noise.

4. MULTIPATH FADING CHANNEL MODEL

A tapped-delay line model shown in figure 1 demonstrates both the properties of flat and frequency selective fading. Each multipath signal has a different time delay (τ), amplitude level (α) and phase shift (ϕ), which will interfere with one another at the receiver, producing a totally distorted version of the original transmitted signal with the additive of noise [5].

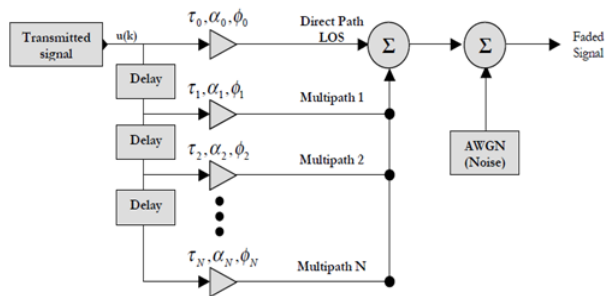

Figure 4: Tapped delay line model of a multipath fading channel.

5. BINARY PHASE SHIFT KEYING MODULATION

The phase of a constant amplitude carrier signal is switched between two values according to the two possible signals m_1 and m_2 corresponding to binary 1 and 0, respectively. Normally, the two phases are separated by 180° . If the sinusoidal carrier has an amplitude A_c and

energy per bit E_b , then the transmitted BPSK signal for $0 \leq t \leq T_b$ is either:

For binary 1 input (Signal m_1)

$$S_{BPSK}(t) = \sqrt{\frac{2E_b}{T_b}} \cos(\pi 2f_c t + \theta_c) \quad (1)$$

For binary 0 input (Signal m_2)

$$S_{BPSK}(t) = -\sqrt{\frac{2E_b}{T_b}} \cos(\pi 2f_c t + \theta_c) \quad (2)$$

Where, $E_b = \frac{1}{2} A_c^2 T_b$

6. SIMULINK MODELS

Figure 5 shows a single-user system Simulink model in which the signal is transmitted over multiple paths. This is similar to a mobile channel environment where the signals are received over multiple paths, each of which has different amplitudes and delays. To take advantage of the multipath transmission, the receiver employs diversity reception which combines the independent paths coherently. The model uses random binary data which is BPSK modulated (real), spread by PN codes of and then transmitted over different channel. The receiver consists of a despreader followed by a BPSK demodulator.

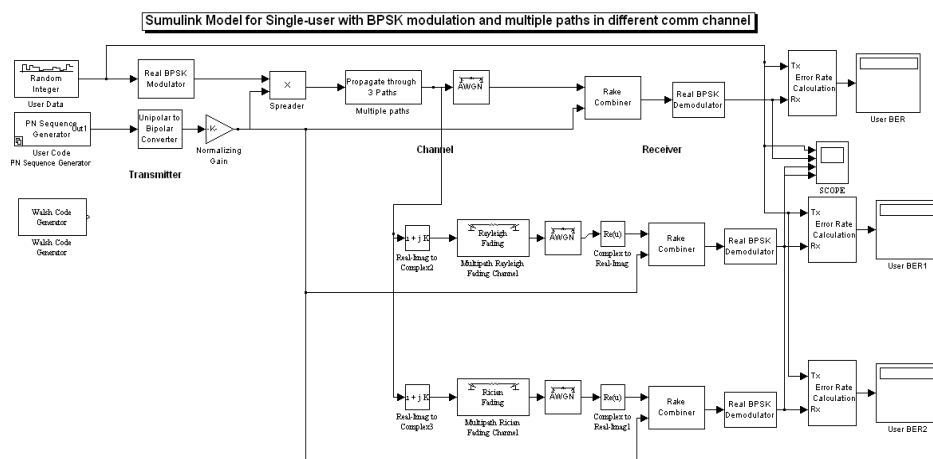
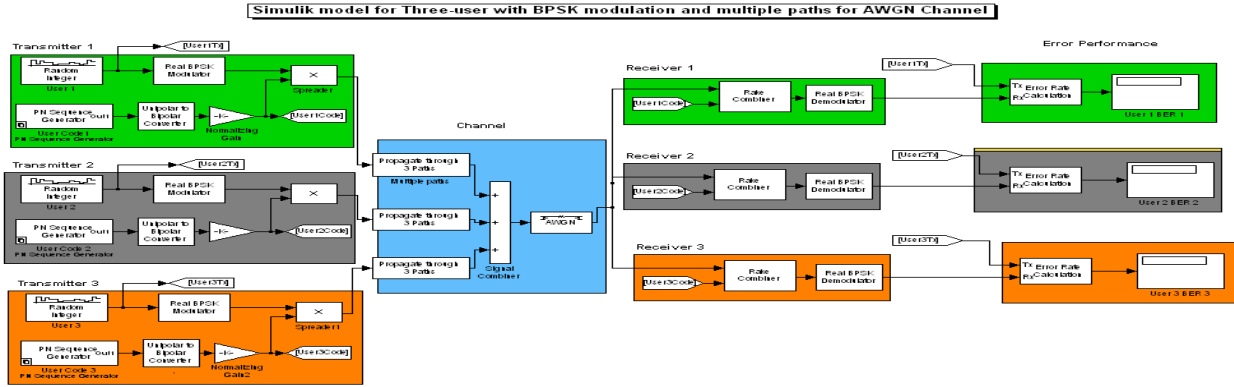

Figure 5 Simulink model Single user Different Channels

As shown in figure 6 , Multi-user data transmission system with the multi data streams being independently spread by different PN codes Note, to keep the system simple, no fading effects are

considered here and the receiver assumes knowledge of the number of paths and their respective delays.



7. RESULTS AND DISCUSSION

BER of DS-CDMA with Rake Receiver measured through MATAL Simulink Model using BPSK in baseband. CDMA is technology for digital transmission of radio signal in telecommunication systems. In this technology, multiple users can transmit the data simultaneously in a channel using same frequency. Each user is assigned a distinguished code for transmission; the data was transmitted to receiver in AWGN and Fading channels. During transmission, SNR values of signal changes to calculate BER value to plot BER vs. SNR graph in AWGN and Fading channel.

SNR	Only USER 1 present	USER 1 & 2 present	USER 1, 2 & 3 present
-10	0.3529	0.3526	0.3525
-4	0.2231	0.225	0.2268
2	0.0673	0.0704	0.0730
4	0.0313	0.0356	0.03731
6	0.0094	0.0121	0.0136
8	0.0014	0.0026	0.0046
10	0.0001	0.0002	0.0006

Table 2 BER for AWGN Channel with Multipath and Rake fingers 3.

SNR in dB	BER in AWGN (%)	BER in Rayleigh (%)	BER in Rician (%)
-10	0.3529	0.4762	0.4621
-4	0.2231	0.4515	0.4252
2	0.0673	0.4065	0.3603
4	0.0313	0.3845	0.3305
6	0.0094	0.3593	0.3002
8	0.00145	0.3325	0.2691
10	0.000125	0.3052	0.2393

Table 1 BER in AWGN, Rayleigh and Rician fading channels over BPSK.

I. CONCLUSIONS

This paper presents a DS-CDMA cellular system using the RAKE receiver. Rake receiver is used for CDMA technique rather than conventional CDMA with matched filter. The added advantage of this technique is to minimize the BER with maximize SNR.

The BER performance will also increase, if increase the number of fingers in Rake Receiver. Compared the BER of the system for different path numbers over Rake. The simulations is done in MATLAB environment. Few Results have shown in appendix.

Adding multiuser degrade the performance of system. BER increases as number of user increases, it has been observed due to adding user causes interference which is distributed (share) among existing users equally and SNR decreases slightly. it has observed by simulink model with three users.

APPENDIX

Results that have been observed are shown below

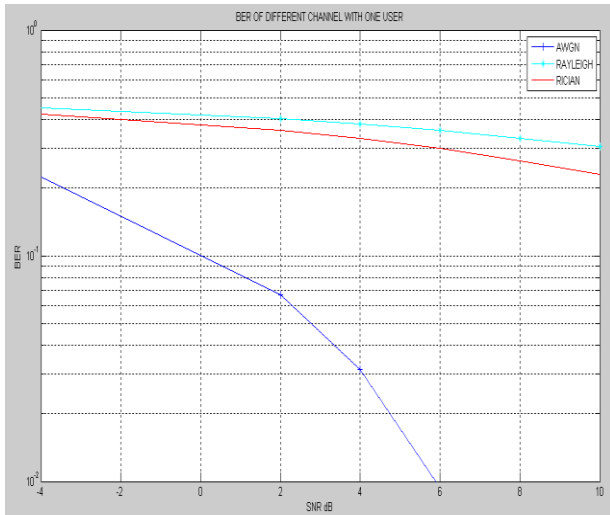

Figure 7 BER Vs SNR graph shows comparison of different channels.

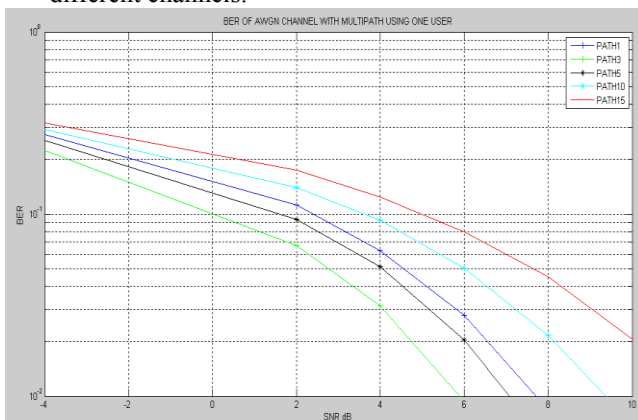

Figure 8 BER Vs SNR graph for multipath in AWGN channel.

REFERENCES

[1] J. S Proakis, "Digital Communications", McGraw-Hill, New- York, 1995.
 [2] Tommi Heikkila, Rake Receiver, Postgraduate Course in Radio Communications Autumn 2004.

[3] Diversity Techniques in Wireless Communication Systems, 16:332:546 Wireless Communication Technologies Spring 2005.
 [4] Wideband DS-CDMA for Next-Generation Mobile Communications Systems, IEEE Communication Magazine September, 1998.
 [5] IEEE standard for wireless LAN: Medium Access Control and Physical Layer Specification, P802.11, January 1999.
 [6] Mohammed Slim Alouini and Andrea J. Goldsmith " Capacity of Rayleigh fading channels under different Adaptive Transmission and Diversity combining Techniques", IEEE Transactions on Vehicular Technology, Vol. 48, No. 4, July 1999.
 [7] Gary Breed, High Frequency Electronics, 2003 Summit, Technical Media LLC "Bit Error Rate: Fundamental Concepts and measurement issues".
 [8] Fumiyaki Adachi, "error Rate Analysis of Differentially Encoded and detected 16-APSK under Rician fading", IEEE Transactions on Vehicular Technology, Vol. 45, No. 1, February 1996.
 [9] Jiho Ryu, Jeong Keun Lee, Sung-Ju Lee and Taekyoung Kwon, "Revamping the IEEE 802.11a PHY Simulation Models", MSWim" 08, October 27-31, 2008, Vancouver, BC, Canada.
 [10] A. Alimohammad, S.F.Fard, B.F.Cockburn and C.Schlegal, "Compact Rayleigh and Rician fading simulation based on random walk processes", IET Communications, 2009, Vol. 3, Issue 8, pp 1333-1342.
 [11] Yahong Rosa Zheng and Chengshan Xiao, "Simulation models with correct statistical properties for Rayleigh fading channels", IEEE Transactions on communications, Vol. 51, No. 6, June 2003.
 [12] "Quadrature Amplitude Modulation", digital Modulation Techniques" www.digitalmodulation.net/qam.html
 [13] Lightwave Magazine, September 2004 article on "Explaining those BER testing mysteries".

- [14] James E. Gilpy, Transcript International Inc., August 2003, "Bit Error Rate Simulation using Matlab"
- [15] A. Sudhir Babu "Evaluation of BER for AWGN, Rayleigh and Rician Fading Channels under Various Modulation Schemes", *International Journal of Computer Applications (0975 – 8887) Volume 26– No.9, July 2011*
- [16] "Performance and Analysis of DS-CDMA Rake Receiver" by Y Mohan Reddy, M Nanda Kumar, K Manjunath, *International Journal of Advanced Research in Computer Engineering & Technology, Volume 1, Issue 3, May 2012*
- [17] "Performance analysis of DS-CDMA rake receiver over AWGN channel for wireless communications" by N.Anand Ratnesh, K.Balaji, J.V.Suresh, L.Yogesh, *International Journal of Modern Engineering Research (IJMER) Vol.2, Issue.3, May-June 2012 pp-859-863*
- [18] Performance and Analysis of DS-CDMA Rake Receiver and Analyzing the BER Performance in Presence of Nonlinear Distortion in DS-CDMA System by Y Mohan Reddy, K Manjunath, K Yogaprasad. "*International Journal of Advanced Research in Computer Science and Electronics Engineering Volume 1, Issue 5, July 2012*"
- [19] Performance Evaluation of Rake and Pre-Rake Receiver for a Wireless DS-CDMA System. "*International Journal of Engineering and Technology Volume 2 No. 7, July, 2012*"
- [20] Improved BER Detection of CDMA IS95A Forward Traffic Channel." *International Journal of Computer Information Systems, Vol. 4, No.4, 2012*"
- [21] BER Improvement of DS-CDMA with Rake Receiver Using Multipath Fading Channel .



Mr. Khaire Ganesh B. Received B E degree in Electronics & Telecommunication from university of Pune, currently

he is doing M Ein Dgital System from Amrutvahini College of Engineering, Sangamner. His area of interest is wireless communication.



Prof. R.B. Sonawane Received M E degree in Electronics He has a 22 years of teaching Experience. He Is Working As a Professor In Amrutvahini College of Engineering, Sangamner . His reaserch interest is in the area of communication,