

Arduino Based Electronic Notice Board and Home Appliances Control by Using Gsm Technology

Bhargavi Motapothula , Pavani Majji, Swathi Nunna , Anjali Kutada

Department of Electronics and Communication Engineering LAKIREDDY BALIREDDY COLLEGE OF ENGINEERING, Mylavaram ,INDIA

Email: mbhargavi98@gmail.com,
pavani.majji07@gmail.com, swathi1996.nunna@gmail.com,

DR.E.V.Krishna Rao

Professor, Department of Electronics and Communication Engineering LAKIREDDY BALIREDDY COLLEGE OF ENGINEERING , Mylavaram ,INDIA

Email: krishnaraode@yahoo.co.in , anjalimahi147@gmail.com

Abstract: Notice boards plays a major role in Educational institutions or any organisations or bus stations and railway stations the information can be shared by means of messages. But sending various messages at a time becomes tedious process by using paper notices . In order to overcome the difficulties we are introducing SMS based notice board . This paper deals with the SMS based notice board incorporating widely used GSM SIM900 for displaying messages via user's mobile . The main idea behind this paper is to provide the simple and flexible way for the user to display notices on the LED display through messages by using GSM SIM900. This GSM SIM 900 module will be used anywhere irrespective of the place where the network connectivity will be available. In this paper we are not only dealing with the SMS based notice board but also with the home appliances control with the help of ATmega 328 controller . With the help of this controller we are controlling home appliances like Fan and light with the help of the messages sent to GSM SIM900. The GSM SIM900 will receive the commands what we sent from the mobile and operation will perform accordingly.

Keywords: ATmega 328 controller , GSM SIM900 LED Display , Mobile

I. INTRODUCTION

With increasing number of notices many trees are being cut and which leads to environmental pollution .The main reason behind this paper is to save lot of trees and also reduce the efforts of human. In this paper , the hardware what we are using is capable of displaying messages and controlling of home appliances electronically with the help of mobile . So, the hardware can be used

for doing two functions . In case of displaying notices , the user can send the message with the

help of mobile to GSM SIM900. The GSM module will receive the commands and send it to LED display. On the LED display the messages will be displayed so the required information will be conveyed. In this case the user can easily know the information by seeing LED Display . If we use the SMS based notice boards electronically there is a fast and reliable communication will be there. Maintenance of GSM based system is easy and the cost for installing the GSM system is flexible. In addition with displaying messages electronically, we are also controlling the home appliances with the help of Arduino .The hardware consists of an ATmega328 controller which is interfaced with the GSM module for transferring data. GSM module has a sim card slot in which the SIM is inserted and the messages has been sent from the mobile to the SIM card. In case of smart home which is nothing but home appliances control, the proposed system will be useful anywhere irrespective of place. So the required user may control the devices by switching it to ON and OFF by sending messages to the SIM which is inserted in GSM SIM900 with the help of mobile phones . The motivation behind this system is to minimize the efforts of aged people in case of operating appliances . It is also useful in situations like whenever the person is not available at home the person will operate the devices with the help of messages send to the GSM module and get serviced. The appliances will be controlled only when the person is in the specified range and there will be network connectivity will be available in the range . If we use this type of system mainly in educational institutions it will reduce the papers for conveying messages . The controlling of appliances will be appliances will be applicable to both the institutions as well as at home.

II. LITERATURE SURVEY

As cellular networks are came into existence in 1970's for increasing the number of frequencies which in turn lead to the development of AMPS(Advanced Mobile Phone System). AMPS is analog based communication comes under 1st generation where as GSM(Global System For Mobile Communications) comes under the category of 2nd generation. The 3rd generation of cellular networks are given based on the GSM standards is UMTS(Universal Mobile Telecommunication System). Before GSM came into existence , people are using CDMA(Code Division Multiple Access) communication for transmission of data as well as for calls. The CDMA requires more energy and power , So the CDMA communication will be replaced by GSM technology. In GSM we are transmitting the data in the form of digital and we are intimating the people by sending messages. This messages can be viewed by the LED display. In the Home automation point of view, Initially we have seen many controllers are integrated with WI-FI , ZIGBEE and BLUETOOTH which are used for controlling the home appliances by sending SMS. The drawbacks in those methods are Short range of communication. The main purpose of using GSM is long range of communication which is upto 35KM range and also GSM requires less power to operate. So this is the reason behind the choosing of GSM SIM900.

III. PROPOSED METHOD

The proposed system is GSM based home automation system and electronic Notice board. Previously the notice board will uses the paper notices and these notices can be replaced by the

IV. COMPONENTS REQUIRED

ARDUINO UNO:

Arduino is a type of electronics in which both hardware and software can be used. It provides flexibility to the user. Arduino Uno is a commonly used ATmega328 microcontroller developed by arduino.cc having 32KB flash memory and 8KB of ROM . The board will have both analog and digital pins. In which some of the pins may act as both input and output pins.

SMS based electronic notice board. The Home Automation System suffers through many problems. Although, this system can be implemented with other communicating modules like Bluetooth module, WI-FI module etc but they have range limitation i.e. They can operate up to a certain distance depending on the range . But GSM based system allows the user to control the device from any part of the world provided that he should be subscribed to a service provider. The system will also give the current status of appliances. The schematic of proposed method is shown in Fig.1., In this schematic diagram power supply is given to LED display and for ARDUINO UNO board. In this mobile is connected directly connected to the GSM SIM900 with the help of sim card inserted in it. Max 232 is connected to the LED display in order to provide the constant output voltage. In this we are using 16*2 LCD crystal display to know the status of the hardware in case of processing the data.

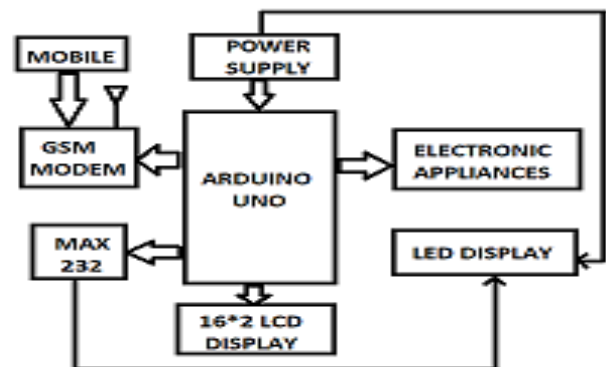

Fig.1.,Block Diagram

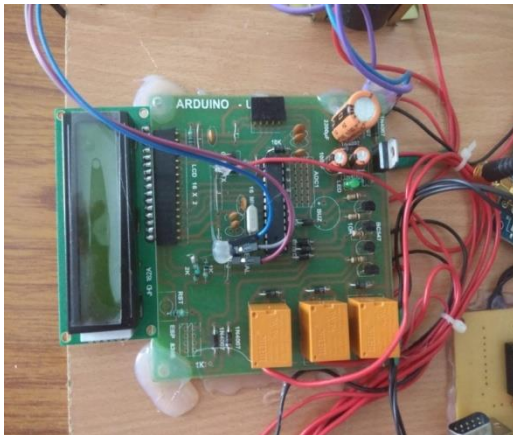

Fig.2., ARDUINO UNO

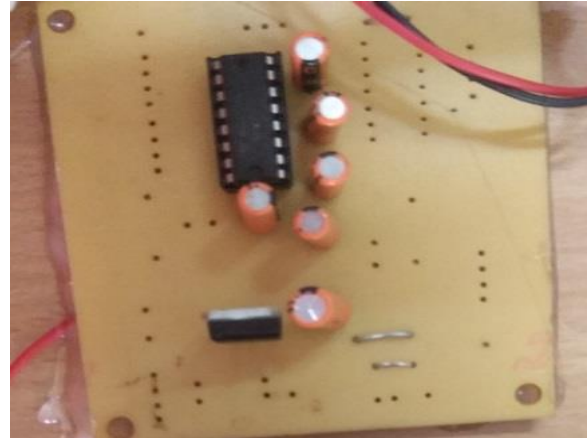

Fig.4., MAX 232

GSM Modem:

GSM is a type of Quad-band architecture, which has frequencies like 850MHZ or 900 MHZ or 1800MHZ or1900MHZ as shown in Fig.3., In this paper we are using GSM SIM900. This GSM module will be used to send messages as well as for accessing internet also . By using this GSM module we can transfer the information up to 35KM range. This GSM module operation will be based on the attention commands (AT commands).GSM module will draws a large current of 2A when transmitting of data will be there.



Fig.3., GSM SIM900

16*2 LCD Display:

A liquid-crystal display (LCD) as shown in Fig.5., LCD is a type of display which uses the properties of crystals in the form of modulating of light. Modulating of light is nothing but increasing the intensity of light .Crystals don't have the property of emitting the light directly. For providing the light we are using some of the reflectors to generate images in the form of color .LCDs can be used in digital clocks with large number of pixels .In this type of LCD we are having 16 rows and 2 columns for displaying text .This LCD has the capability of displaying 32 characters including spaces.In the background of LCD it is having a LED in order to provide the light as crystals are not capable of providing of light.

MAX 232:

MAX232 is a type of IC(Integrated Circuit) which transforms one form of signal into another form .With the help of this IC we can convert serial communication that is serial port signals into TTL compatible signals. MAX232 will acts as a transceiver which is used to convert the Received ,Transmitted and control signals as shown in Fig4.,



Fig.5., LCD Display

LED Display:

An LED display is a type of display in which all the Light Emitting Diodes(LEDs) are arranged in flat like structure as shown in Fig.6.,.This display has the similar type of LEDs which emits the light. Now a days these type of LED displays can be used any where only because of their brightness and they can be visible in sunlight too. This displays can be used in bus stations, railway stations etc.,This displays can share the information quickly because of their visibility.



Fig.6., LED Display

Power supply:

Power supply is the main source for any electronic or electrical devices to be operate . with out the power supply we can not operate the devices . Large amount of supply will be converted to small and required amount of supply with the help of transformers. With the help of transformer we can convert the AC supply to DC supply because all the appliances will operate with Input supply as DC.

Relay:

Relay is a type of circuit which is used provide the isolation between the devices . Internally relays are having coils whenever we are giving power supply the magnetism will be produced and the switches will come together . We are having four types of configurations in relays . Those are SPDT (Single Pole Double Through) SPST(Single Pole Single Through),DPDT(Double Pole Double Through), DPST(Double Pole Single Through).

USB driver :

USB driver is a type of connector through which we can connect MAX232 and LED display.

Mobile:

Mobile is used to send the messages to the LED display as well as control the home automation by giving respective commands as mentioned in the program.

V. SYSTEM DESCRIPTION

The system what we haveproposed will work on the following steps.

- Connect all the pins
- Then give power supply to LED Display and Arduino board
- Initialise the LED Display and GSM modem
- Format all the previous messages
- Enter the respective commands to display messages
- control the home appliances with the help of Arduino

The flowchart for the proposed method is shown in Fig.7., According to the steps given in the flowchart the system will works and gives the output.

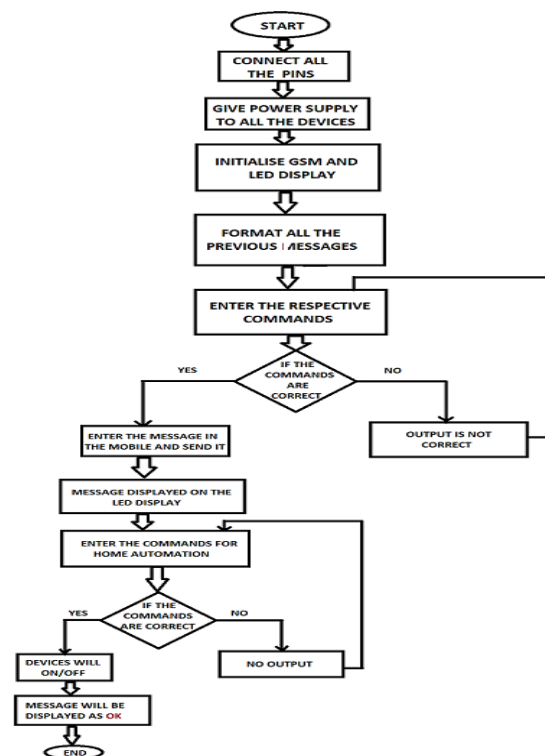

Fig.7., Flowchart for Proposed Method

VI. IMPLEMENTATION OF PROPOSED METHOD

- In this method we are doing two processes
- a. Displaying message on the LED display for displaying Notices
 - b. Controlling of home appliances by using arduino

a. The GSM Module which is used consisting of a SIM card slot is having a SIM card inserted in it . This GSM module works with Attention commands (ATcommands) set. The pins TXD, RXD and GND are connected to the GSM module from Arduino UNO. So, that the message is transmitted from mobile to GSM module and in the background it is using a attention command is AT+CMGS. Until the AT+CMGS command is executed the LED display showing the previous messages which are stored in the SIM . So, we have to format the previous messages by using the command which is given in the programming procedure . If we have to send the message to the LED display first it should reach the GSM module and then it reaches the LED display. In this we are providing an interface between LED display and Arduino uno by using MAX232 .

b. The arduino uno(ATmega328) controller used to control the home appliances. The relays what we are using on arduino board having coils inside it, whenever we give the power supply the coils come together produced magnetism property and thus the appliances will operate. This home automation can be done by the messages sent to GSM and thus we can ON/OFF the devices by giving respective commands .

VII. RESULTS:

WHEN THE MESSAGES ARE GIVEN TO DISPLAY NOTICES

The process of displaying of messages will be given by the functions declared in the program and the message will be send to the SIM which is inserted in the GSM modem and the message will be displayed on the LED Display as shown in Fig.8.,.



Fig.8., Message shown on the display

FAN CONTROL

The controlling of fan can be done with the help of Arduinio Uno and the corresponding messages will be sent to the GSM from the mobile as shown in Fig.9.,



Fig.9., Controlling of Fan

LIGHT CONTROL

The controlling of Light can be done with the help of Arduinio Uno and the corresponding messages will be sent to the GSM from the mobile as shown in Fig10.,



Fig10., controlling of light

FORMATTING THE PREVIOUS MESSAGES

If we have to update the messages we have to Send the message as FORMAT to clear the previous messages .Then enter the new message in the mobile and send it to the SIM card to which we have inserted in the SIM Slot of GSM SIM900 as shown in Fig11.,.



Fig11., Formatting the messages

VIII. ADVANTAGES

The following are the advantages of proposed method

In case of Electronic Notice board

- Used for displaying notices with the reduction of paper
- Reduce the physical effort for printing the notices

In case of Home Automation

- Reduces the efforts for aged people
- Time saving to operate devices
- Energy consumption is less

IX. APPLICATIONS

It can be used for

- Advertisements
- Traffic Light Control
- Bus stations, Railway stations
- Stock Exchanges

X. CONCLUSION

From the analysis of proposed method, this paper will give a brief idea about the implementation of Wireless electronic notice board and control of home appliances with the help of ATmega 328 microcontroller and GSM SIM900. As this system is more easy and flexible for operation as well as to share the information in organizations in the form of notices. This type of information sharing will minimize the efforts of people in pasting the paper notices and also in printing the forms. In case of home appliances control it will reduce the difficulties in the operation of devices like Light and Fan etc.,

XI. FUTURE SCOPE

In future we can enhance this system for High power consuming devices like air conditioners, microwave ovens, Geysers, washing machines can be controlled with the help of ATmega328 controller in case of Home Automation. Not only in the case of home automation we can also provide the security in Notice boards too. We can provide the more security by giving one time password for the authenticated users for sharing the information.

References:

- [1] R. Teymourzadeh, S. Ahmed, K. W. Chan, and M. V. Hoong, "Smart gsm based home automation system," in Systems, Process Control(ICSPC), 2013 IEEE Conference on, Dec 2013, pp. 306–309.
- [2] Muhammad Ali Mazidi, Janice G. Mazidi, Rolin D. McKinlay, The 8051 microcontroller and embedded systems using assembly and C, 2nd edition 01-Sep-2007, Pearson Education India.
- [3] www.wikipedia.org
- [4] <http://www.newsms.com/doc/configuring-smsconnections/gsm-modems>
- [5] <http://arduino.cc/en/main/software>