

Study on the Feasibility of Optical Reflectance Topographic System

Saravana Kumar T.¹& Prof., Jeeva J.B.²

^{1,2} Department of Biomedical Engineering, School of Bio Science and Technology (SBST), VIT University, Vellore, India.

Abstract-

Light reflected back from the surface of skin is consists of two elements: normal reflectance or else the "glow" echoing from skin surface and backscattering of the light from the deep and shallow tissues inside. The normal reflectance comprises of the noticeable indications associated to surface nature, whereas the light received from the backscattering is full on information relevant to skin tone, erythema multiforme, and other intra-cutaneous anatomy. A weightless hand operated device that combines an optical source that lime lights the area to be diagnosed and the photodiode array. The photodiode array picks up the scattered light from the skin surface. The output from the photodiode is made into voltage of acceptable level and read by the computer for processing. The maxim is that the light backscattered from regular and irregular tissue is predominantly distant due to differences in their absorption, transmittance and reflectance qualities of light. These differences are so evident that it can be used to identify the existence of cancer in the superficial layers of skin.

Keywords:

Reflectance; Backscattered light; Laser reflectometer; Tissue equivalent Phantom

I. INTRODUCTION

Diagnosis of human body with the usage of light as a tool is an ingenious thinking. Presently, tissue delineation by the use of laser as a source is widely acclaimed as a

propitious detection tool, by the reason that optical radiation is noninvasive [1]. By figuring out the tissue-laser synergy one can determine the pattern of superficial tissue. Hence, diagnosis with the help of optics is promisingly acceptable, for early finding of any irregular pattern of tissue; faster than the present available methods.

Human skin is the integument, or shield, of our human body and it gives safety for vital organs inside in addition as a sensory organ. The skin is made up of three specific tissue layers. They are the epidermis, an peripheral layer that constitutes the foremost protective layer, the stratum corneum or the dermis, a fibrous portion that lends strength and support for the epidermis; and the subcutis, a subcutaneous fatty region underneath the dermis that nourishes the two upper layers by its blood vessels and in addition cushions and insulates the body [2].

The shielding property of the skin confines the body from the constant threats of various offenders. This resulting strain on the skin most often results in various changes in the corporal structure. The cause of occurrence of this strain and whether it actually develops into a malignant by damaging the neighboring tissues or just stays as a benign is the greatest risk to the health of the person. Benign noncancerous swells results visible displeasing attention but anyways they are regarded harmless, whereas cancerous malignant lesions which are able to proceeding into cancer are very pernicious and demands prompt consideration [2]. Cancer usually originates in the superficial part of tissue and skin i.e., epidermis. Identifying the irregular patterns in the superficial tissue portion through naked eye is unachievable task [1].

The tissue equivalent phantoms play an important and concluding role in determining the functioning of any novel diagnostic approaches. Thus, the tissue equivalent phantom helps in calibration, inspection and standardization of the method before deploying for clinical trials. The success of this experiment not only lies on the design of the optical setup but also in the selection of appropriate material for making the ideal phantom, so that it is able to mimic the properties of the tissue. Therefore the aspiration of this work is to develop a reflectometer that is used for measuring the back scattered light form the skin and to make a phantom that mimics the real tissue and after proper analyses with the phantom taking it over to human soft tissues.

II. MATERIALS AND METHODS

A. Laser Reflectometer

The laser reflectometer is a device which consists of a light source that illuminates the region under diagnosis and also collects the backscattered light by the help of photo diodes. These photo diodes pick up light which are backscattered through reflectance. As said before, it consists of a laser source and three photo diode array which are place at appropriate distance from the light source and thus results total collection of backscattered light [3, 4]. The specification of the laser light source is 670nm, 3mW. Trans-impedance amplifier is used for amplifying the weak signal from the backscattered light and a Data acquisition card for communicating with PC. The pitch distance for the photo diode and laser is 3mm and for the diode to diode is 2mm. The backscattered light photons originating from the topmost tissue layer are received by the first photo diode from the source whereas the backscattered light from the depths are received by the next photo diodes. The schematic of laser reflectometer for measuring the surface profile is shown in Fig. 1.

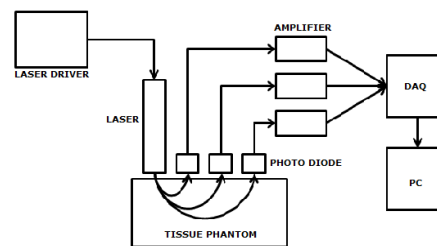

Fig. 1. Light Reflectometer

B. Phantom Preparation

White paraffin wax in calculated quantity is melted along with proportional amount of red wax coloring agent (Camel wax crayon, Ltd.) to makeup a 100ml molten mixture. This molten mixture is formed by continuous thorough mixing of the dye with the paraffin. Normally for giving color to the molten mix four dyes are preferred. They are red, black, brown and white [3]. After homogenous mixing of the dye the mix is transferred to the beaker whose size matches is same as our requirements. Here the beaker is of 10cm by diameter and 5cm by height. The mix is poured to a height of 2cm and to mimic the presence of irregularity in the phantom [1], a stone is embedded inside the mold and it is again covered with the mix. This is then allowed for cool down. After solidification, the phantom mold was carefully taken out from the casting beaker.



Fig. 2. Tissue Equivalent Phantom

B. Data Acquisition

Data acquisition and logging is done by first forming a grid over which the reflectometer setup can be moved across it. The grid is formed in 2x2 mm matrix fashion. For each grid position the

three photo-diode values are collected. This value gives the backscattered light from the tissues and these signals are given to a trans-impedance amplifier to get converted signal i.e., current to voltage. Then this amplified signal is taken to PC through a DAQ card. In PC, the digitized value of the signal is displayed. The laser reflectometer is scanned over the phantom and the values are collected and logged in EXCEL sheet for processing. The grid is useful in covering the entire scan area precisely. Hundred samples are taken for each diode for a particular grid position. This was done to ensure the proper working of the reflectometer in identification of the known abnormality in the phantom. After this prelim went successful, the reflectometer was ready to be tested on subjects. The muscle region between the index and the middle finger was chosen. Because this region is most suitable with thin skin layer bounded by bones of the finger on the sides. Like the gridding we did on the phantom, this muscle region was also marked, and the laser reflectometer was moved across it and the readings were taken. The marking were made such that they were over from the metacarpals of the index and middle finger. The interspace between the metacarpals contains the soft tissue. The marking had 8 points from the middle of both the fingers, with the centre point straight over the soft skin between the two fingers. The gridding on the hand over which the scanning was done is shown in Fig 4. The LabVIEW coding for collecting the signal is shown in Fig 5.



Fig. 3. Scanning Grind lines

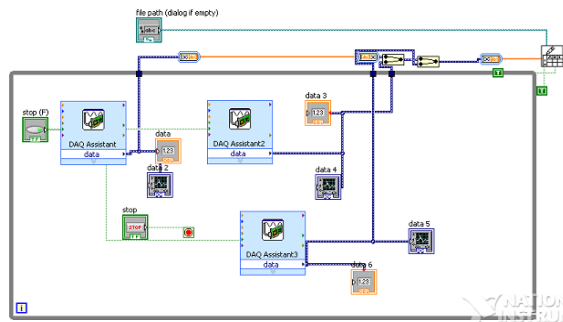

Fig. 4. Data acquisition through LabVIEW

III. RESULT & DISCUSSION

The collected data is then tabulated for each diode for each subject. These collected values were then plotted into a graph form. The exponential decreasing nature of the signal (the reflectance profile) in the Fig 5, is due the distance between the source and the photodiode. The photodiode very near to the source gets more reflected light and hence the intensity is also more and it decreases with distance and that explains the exponential decreasing curve. From the Fig 6(a, b, c) the elevation in the centre region shows the presence of soft tissues. Since this region is made of soft tissues, the reflectance is this area is more and hence the light incident on the photodiode is also high, whereas the side region is depressed and this is due to the presence of bones. Bones has the property of absorbing light and hence the light incident on the photodiode is less and so as the values. The Fig 7(a) shows good results because of the proximity with the source whereas Fig 7(b, c) are more or less same with minimal variations because of their distance from the source.

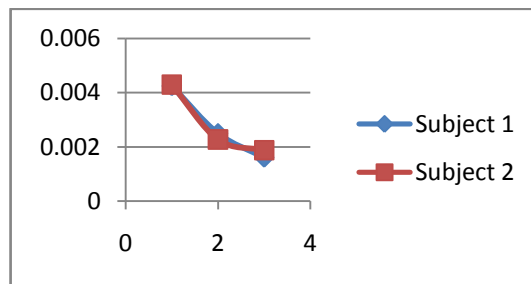

Fig. 5. Reflectance profile

The backscattered light photon concentration figure has huge interrelationship to the network and objective figures of the phantom which in turn relates to the tissues. When light reaches the skin, some of them are reflected while some are absorbed. This phenomenon takes place in skin, where there are variations in skin texture and tone [5, 6]. Pigmentation, dimension, and variations in texture in deeper sections are the elements that materialize the amount of light to get scattered back [1, 3]. The above findings can be more encouraged in resolving the optical characters for real organ parts. Phantoms which are made comparable to tissue by adding wax coloring agent in precise amount to the white paraffin wax.

Since the third diode is at distance of 18mm which is quite far from the source the amount of light received by this diode is not enough for proper finding of the skin texture but also this is useful in find the texture of the deeper tissue because of its position.

IV. CONCLUSION

To consummate, this approach could be employed in imaging for medical application by optical portrayal of human organs in a noninvasive gizmo.

REFERENCES

- [1] R. Srinivasan, D. Kumar and Megha Singh, Optical tissue-equivalent phantoms for medical imaging, Trends in Biomaterial Artificial Organs. Vol. 15(2) pp 42-47 (2002)
- [2] Bardia Amirlak, Ladan Shahabi, Skin Anatomy Medscape, Feb-2013
- [3] Steven L. Jacques, PhD, Jessica R. Roman, MS, and Ken Lee, MD., Imaging Superficial Tissues With Polarized Light, Lasers in Surgery and Medicine 26:119–129 (2000)
- [4] Cubeddu R., Pifferi A., Taroni P., Torricelli A., and Valentini G, A solid tissue phantom for photon migration studies, Phys. Med. Biol, 42, 1971-1979 (1997)
- [5] G.Jagajothi, S.Raghavan, Estimation And Measurement Of Biological Tissues Using Optical Simulation Method, Progress In Electromagnetic Research M, Vol. 6, 155–165, 2009
- [6] Fodor. L, Elman. M, and Ullmann. Y Aesthetic Applications of Intense Pulsed Light ISBN 978-1-84996-455-5

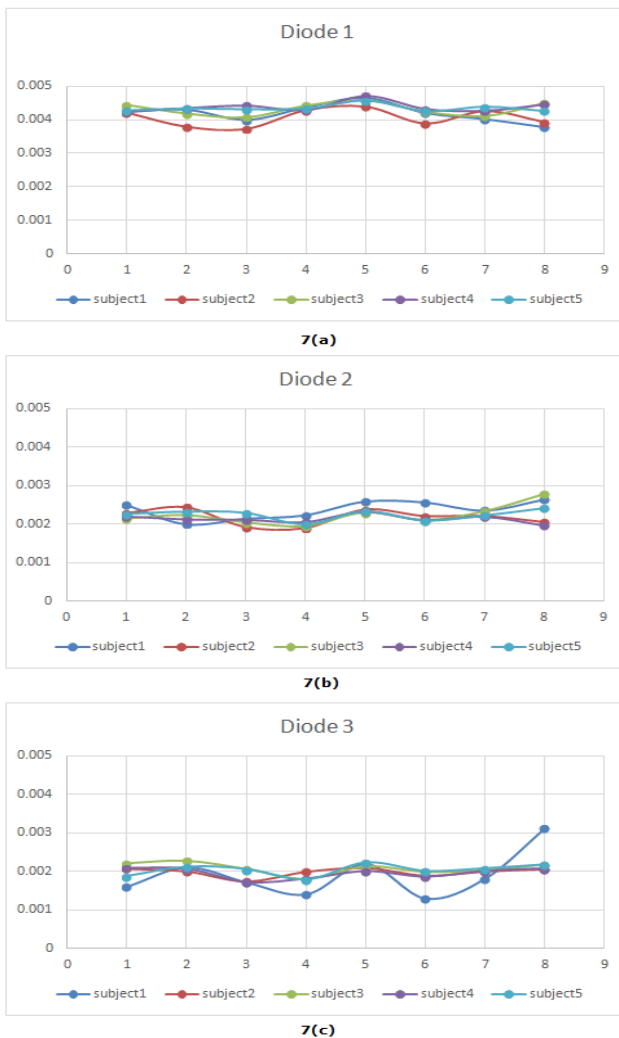

Fig. 6. Signals from the (a) diode 1, (b) diode 2 and (c) diode 3.