



## **Industry Process Automation Using Programmable Switching**

**Mr. Balaji. V. Phad (Author)**

Integrated Power System Dept.

Tulsiramji Gaikwad-Patil College of Engineering and Technology, Nagpur University, MH

Email: keshavphad28@gmail.com

**Dr. H. K. Naidu (Co-Author)**

Integrated Power System Dept.

Tulsiramji Gaikwad-Patil College of Engineering and Technology, Nagpur University, MH

Email: hod.electrical@tgpct.com

**Prof. Pratik Ghutke (Co-Author)**

Integrated Power System Dept.

Tulsiramji Gaikwad-Patil College of Engineering and Technology, Nagpur University, MH  
Maharashtra

Email: pratik.ghutke@tgpct.com

**Abstract** - The project consists of a Power meter reader system with GSM (sms sender device) interface. The energy department needs to send its employees every month in order to take energy meter readings. This is an expensive as well as a time consuming system. Our project determines a more efficient way to get energy meter readings.

Both Electricity Company as well as user get their energy meter readings via sms every month. User may also control the system using sms. The energy meter is interfaced to a microcontroller of 8051 family. The energy meter readings are also read by the microcontroller and displayed on an LCD Screen, this data is also sent via sms through a GSM modem interfaced to the microcontroller.

The GSM modem also has sms receiving capability. On receiving particular user request it sends required signal to the microcontroller in order to do counting for required operation. It can switch loads On/Off as desired.

### **I. INTRODUCTION**

The main objective of the project is to develop a GSM based energy meter reading system and load control through SMS. Electricity department sends employees to take meter reading every month, which is an expensive and time consuming job. The proposed project provides a convenient and efficient method to avoid this problem. The electricity department and the user can get the readings of the energy meter of consumers via SMS.

Papers presented in ICIREST-2018 Conference can be accessed from

<https://edupediapublications.org/journals/index.php/IJR/issue/archive>

The loads can also be controlled by the user of this system via SMS using this project.

A microcontroller input is effectively interfaced to a digital energy meter that takes the reading from the energy meter and displays the same on an LCD. The reading of the energy meter is also sent to the control room by an SMS via SIM loaded GSM modem. This GSM modem can also receive commands from the cell phone to control the owner's electrical loads. It uses a standard digital energy meter that delivers output pulses to the microcontroller to perform counting for necessary action. On receiving command it can switch ON/OFF the loads.

Further this project can be interfaced with a non-volatile memory IC like EEPROM along with a keypad so that the user can change the mobile number as per the requirement.

### **II. BRIEF LITERATURE SURVEY**

[1] Automatic Meter Reading (AMR) technology, electrical utilities (EUs) have been exploiting their own infrastructure to bill their customers in an efficient and economical way. Since the amount of data that has to be sent is quite low related to the available time to perform this task, AMR applications have been demanding low bit rates. At this moment, EUs are exploring and demanding other services as load and alarm management, remote monitoring and disconnections, etc. In this



context, the Low Voltage modems should provide more throughout while keeping the cost of the hardware low.

The results of this low complexity AMR technology are that in order to deploy an AMR network, the cost of the equipment on the customer premises and the added value services that the system provides are two key factors in its business case.

[2] It describes the different methods by which distribution transformer loads can be allocated for power-flow studies. Individual distribution loads are calculated using four different methods of allocation. The results of the power-flow studies are compared to those determined using the actual customer meter readings.

Daily kWh, Monthly kWh, Transformer kVA.

[3] A microprocessor-based automatic meter reading system is implemented, which provides a cost-effective, reliable, and interference free data transfer between remote meter reading units and the utility control centre. The meter reading and management processes are free from human involvement. Based on the existing telephone networks, it is very flexible for the utility companies to access, service and maintain this meter reading system. A user friendly and window based user interface is designed which fully utilizes the personal computer's terminate and stay resident programming technique to achieve communications between the remote meter reading units and the personal computers in the utility control center. This paper describes the hardware design of the remote reading unit and the software implementation of the communication module and user interface.

[4] We propose a novel Automatic Meter Reading (AMR) system using the IEEE 802.15.4-compliant wireless networks. The mesh network based automatic utility data collection system (AUDCS) provides a cost-efficient solution by exploring the self organization, self-healing capabilities of the mesh networks and utilizing the state-of-art semiconductor chips and the radio transceivers compliant with IEEE

### III. RESEARCH AND OBJECTIVE

#### 1. Modeling of Device.( all Units)

- Input controlling unit
- GSM Operating unit
- Energy meter and Processing Unit

#### 2. Design of Controller using microcontroller 8051.

3. Design of GSM based configuration model .
4. Design of combinational cycle of energy meter, Loads etc.
5. Design of relays for each load and project model.
6. Connection all units in sequential order.
7. Observing the billing of each operating load and which is controlled

### IV. BLOCK DIAGRAM

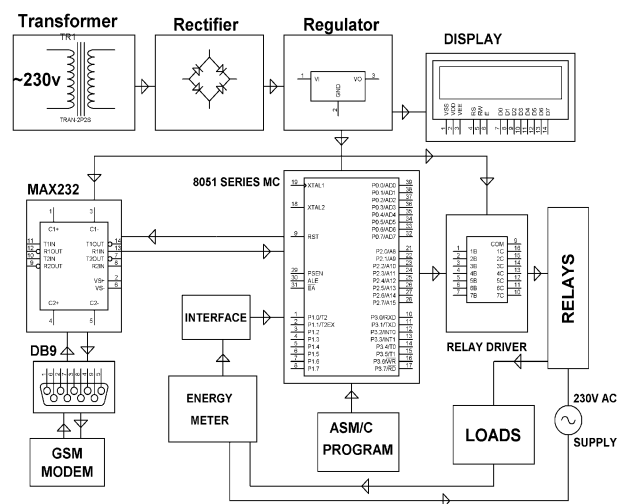

Figure 1: Block diagram of industry process automation using programmable switching GSM

### V. HARDWARE REQUIREMENTS

8051 series Microcontroller, Level Shifter IC, GSM modem, LCD, LED, Crystal, Relay driver IC, Resistors, Capacitors, Diodes, Transformer, Voltage Regulator, Opto Isolator, Digital Energy Meter, Lamp.

### VI. SPECIFICATIONS PREFERRED

The specifications used for the design and development of this wireless energy meter are given below. This system is also used to disconnect the power supply to the house in case of nonpayment of bill and also in case of heavy usage of load than specified.

1. Input voltage: 230V
2. Operating frequency: 50HZ
3. GSM modem: Tri band GSM modem
4. MC input voltage: 5V
5. Memory: Non- volatile



- 6. Display System: LCD display
- 7. GSM Frequency: 400-450 MHZ

#### VII. CONCLUSION

GSM based energy meter is easy to installation and beneficial for both energy Provider and Customer. This reduces the manual cost and also reduces the errors done by the humans. This also reduces the problems faced by customer like over running of the meter, over load, and also reduces thefts. Whenever fault occurs it indicates to the customer. Then customer can inform to the company then energy Provider Company can cut the power easily by sending the SMS to that particular ID number which is connected to the SIM number. The statistical load used and profile help the customer to manage their energy consumption. This helps them to reduce their outstanding dues. This system can be used even in the remote areas by changing the type of the modem, and its range of frequency for communication. This device reduces all cases of revenue problems to the country and helps us to improve our usage.

#### REFERENCES

- [1] W.Amer, Y. Attitude, A. Nadeem, Abdul Ghafoor 2010. Comprehensive E-monitoring, E-management and E-billing system with ZOOM-in ZOOM-out Capabilities to Reduce Electricity Distribution Loses for Developing Countries. 4th IEEE Annual System Conference, PP:174-177.
- [2] Shi-Wei Lee, Design of an Automatic Meter Reading System, IEEE IECON 22nd International conference, Aug 1996.
- [3] H.G.Rodney, Tan IEEE, C.H.Lee and V.H.Mok, 2007. Automatic Power Meter Reading System using GSM Network. The 8th International Power Engineering Conference, PP: 465-469
- [4] T.Chandler, The Technology Development of automatic metering and monitoring systems, IEEE International Power Engineering Conference, Dec 2005.
- [5] Power Meter Store. Measure Power at the plug. Web. 30 november 2010