



A Novel Simulation And Implementation Of Single Phase Buck-Boost Inverter.

¹Snehal Gatkiné

P.G.Student ,

Department of Electrical Engineering,
Tulsiramji Gaikwad-Patil College of
Engineering & Technology,
Nagpur, India

snehalgatkiné@gmail.com

²Hari Kumar Naidu,

HOD,

Department of Electrical Engineering,
Tulsiramji Gaikwad-Patil College of
Engineering & Technology,
Nagpur, India

hod.electrical@tgpcet.com

³Vaishali Pawade,

Guide ,

Department of Electrical Engineering,
Tulsiramji Gaikwad-Patil College of
Engineering & Technology,
Nagpur, India

vaishanipawde@gmail.com

Abstract -The buck-boost inverter provides boosting and inversion function in a single power processing stage based on the front end buck-boost converter characteristics. The static stabilizer offers a reasonable on slow servo controlled stabilizers well as other static tap changing stabilizer. The basic topology is with buck-boost transformer with high primary to secondary ratio for voltage correction of 25%. The control voltage is imposed on the primary of buck-boost transformer. The voltage regulation of this topology is achieved electronically with the step changes in voltage. This task is accomplished through a feedback and control system implemented. The system used IGBTs as power switches. Direct AC-AC converter circuit improves the overall system response and fast voltage correction. Number of storage capacitor increase life of the system. 20 KHz PWM control operation using Microcontroller Atmega16 to achieve time of 1 to 1.5 cycles. Simulation results assure the proposed idea of single phase buck-boost inverter.

Keywords- buck-boost inverter , PWM .

1.Introduction

The good functioning of the majority of electrical and electronic equipment depends on the supply voltage correctness and steadiness. Nowadays, many industries and private users are subjected in long-lasting fluctuations that can be inconvenient or even dangerous. AC voltage stabilizers are used for obtaining a steady AC supply with very close tolerances from fluctuating mains. They find application in a very wide variety of fields. Static Voltage Stabilizer is an IGBT based PWM type buck-boost voltage stabilizer which has tight regulation and fast correction speed which is impossible to obtain conventional

methods. In this topology there is no need to convert the AC input to DC and again convert it back to regulated AC output. This simplifies the design, reduces the component count and improves the efficiency and reliability. The power stage is an IGBT chopper control.

The chopping frequency is around 20 KHz which ensures absolutely silent operation and pure sine wave output (no waveform distortion). The control section is based on micro controller which ensures quick correction of output which is not possible in conventional relay type stabilizer or servo controlled stabilizers. Since the circuit is fully solid state (no mechanical or moving parts) there will not be any wear and tear like the brush wear in servo stabilizer or relay degrading in relay based stabilizer. This is especially useful in places where we need very fast correction speed, constant output voltage, overload current limiting and short circuit protection, soft start, high voltage cut-off and low voltage cut-off, automatic bypass, no wear and tear, long life and maintenance free which is impossible with other conventional relay type or servo control stabilizers.

3. Brief Literature Survey

[1] This paper presents A single phase two-quadrant PWM rectifier to power fixed DC voltage at the



input of inverter module will be presented in this paper. The proposed PWM rectifier can be operated as a Single phase bridge rectifier to maintain well-regulated and boosted DC-link voltage for Inverter module. The control of this converter is realized using analog type closed loop circuit. A proportional-Integral type controller is designed, and the PWM type switching control signal for IGBT is generated by Op-amp circuitry. In idle case, the proposed PWM rectifier can be arranged to act as a single phase full bridge rectifier.

[2] This is an SMPS type voltage stabilizer for mains voltage (AC input and AC output). This is a new switching topology where PWM is made directly in AC-to- AC switching, without any harmonic distortion. In this topology there is no need to convert the AC input to DC and again convert it back to regulated AC output. This simplifies the design, reduces the component count and improves the efficiency and reliability.

[3] In this the author analyzed that the Voltage stabilizer provides an output voltage with a specified limit for supplying to load irrespective of wide fluctuation in the input voltage, independent of load power factor and without introducing harmonic distortion. The voltage stabilizer adjusts automatically the voltage variation whether high or low to the proper voltage level necessary for the safe operation of equipment's.

[4] This paper proposes the design and implementation of a microcontroller-based single-phase automatic voltage regulator (AVR). The basic building blocks for this design include a PIC 16f 628 microcontroller, a triac, a step-up transformer, a zero crossing circuitry and a load voltage sensing circuitry. This design is based on the principle of phase control of ac voltage using a triac. The trigger pulse for the triac is delayed by the microcontroller to provide the desired regulator terminal voltage. This voltage is always sensed and fed back to the microcontroller via a measuring unit to get a continuous control system.

One of the intentions to develop this AVR is to use it in domestic heating and lighting controls.

[5] In this present paper, stress has been laid upon the present scenario of power quality in every grid. With more and more use of nonlinear electrical loads instead of linear loads, we get increased efficiency with reduced power requirements; however this degrades the power quality of whole power system. Power quality is basically determined by the voltage.

3.Objective and Research

AN APPROACH FOR STABILIZATION OF VOLTAGE:

In this IGBT based PWM type static voltage stabilizer only the difference in voltage is switched through IGBT and will be added or subtracted from the mains. This is done electronically without any step changing in voltage which occurs when the system regulates. This is achieved by a feedback control system using microcontroller. The output voltage is sensed by the microcontroller and corrections are made by varying the duty cycle of the PWM. This stabilizer boosts up Block diagram of the voltage if it is low and bucks the voltage if it is high.

The secondary winding of the buck/boost control transformer is connected in series to the supply line going to the load. Its primary winding is fed with a voltage from a IGBT based AC-AC converter. AC-AC converter input is connected across the output supply. The voltage is induced in the secondary winding gets added to or is subtracted from the mains voltage depending upon its phase with respect to the line voltage. The induced voltage will either be in phase or out of phase by 180 with the supply voltage. Buck or boost voltage is obtained based on the output and is obtained by changing AC-AC converter output polarity. Output voltage amplitude is changed by changing the PWM duty cycle, PWM duty cycle of 20 KHZ frequency vary from 0-95% to regulate the output voltage in case of buck and boost mode. The correction time of the SVS is as low as 30ms. Microcontroller core based digital control ensures the cycle by cycle correction to meet the voltage sensitive machine and load voltage requirement. Static Voltage Stabilizer has inherent input and output voltage (high/low) cut off detection and will trip in specified time to protect the load. Beyond the nominal input voltage range, stabilizer will continue feeding the load at unregulated voltage. As soon as the unregulated voltage tries to cross the cut off limit, Stabilizer will protect the load by disconnecting the supply. The integrated controller for voltage



stabilizer CONTROLS the output voltage, TRIPS under fault conditions and also DISPLAYS input, output voltage and load current, on LCD display panel simultaneously.

symmetrical and easy to control. The other desirable features include good efficiency during optimal number of device switching's and reduced switching issues. The proposed inverter has a number of attractive features, such as covering the low and variable input voltage, low switching losses, boosting and inversion functions, few voltage and current sensors, and finally resulting in a low cost solutions.

4. Block Diagram

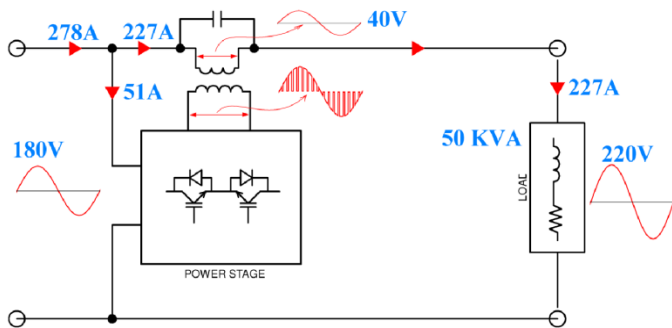

Figure 1: Block diagram of Static Voltage Stabilizer (buck mode)

5. Hardware Requirements

MATLAB SIMULINK, ATMEL STUDIO 6.0,
 PCB ARTIST, SINAPROG

6. Conclusion

A single phase buck-boost inverter has been proposed in the paper. The topology is simple,

References

- [1]Pratik J. Munjani¹, Nitin H. Adroja², Vinod J. Rupapara³ Modelling of PWM Rectifier for Static Automatic Voltage Regulator, International Journal of Advance Engineering and Research Development (IJAERD) ETCEE-2014 Issue, March 2014, e-ISSN: 2348 - 4470 , print-ISSN:2348-6406
- [2] Matrín "Electronic Devices & Instruments" AC –AC PWM mode Static voltage Stabilizer using IGBT and DSP".
- [3] "AUTOMATIC VOLTAGE STABILIZER" prepared by Electrical Division MSME-Development Institute Ministry of MSME Government of India 34, Industrial Estate Nunhai , Agra- 282001
- [4] Nang KaythiHlaing "Microcontroller-Based Single-Phase Automatic Voltage Regulator" 978-1-4244-5539-3/10/\$26.00 ©2010 IEE
- [5] S.Gupta "POWER QUALITY IMPROVEMENT USING PWM VOLTAGE REGULATOR" IJMIE Volume 2, Issue 5 ISSN: 2249-0558