



Design, Modelling and Analysis for Experimental Investigation of Double Spring Damper Shock Absorber Performance

Vidhyadhar P.Kshirsagar¹

Assistant Professor, Mechanical Engineering Department
Tulsiramji Gaikwad-Patil College of Engineering and Technology, Nagpur

ABSTRACT: This paper includes the design, modelling and analysis of conceptual hybrid double spring damper shock absorber. The function of all the components like piston valve, compression and rebound chamber and the flow analysis of the fluid through these valves are studied in detail by designing the double spring damper shock absorber using 3d software. The performance evolution of double spring damper shock absorber with experimental investigation using simulation and modelling. Damping characteristics of double spring damper shock absorber is analysed. The proposed hybrid model of the double spring damper shock absorber is considered as two modes of damping force according to the position of piston. For the simulation validation of vehicle-dynamic characteristics, the double spring damper shock absorber is mathematically modelled. And the vehicle dynamic characteristic of the double spring damper shock absorber is analysed using quarter car model.

Keywords: 3D software, Double spring damper shock absorber, Modelling, Simulation.

I. INTRODUCTION

A shock absorber is one of the components of the suspension of a car. It is designed to deflect vertical and lateral vibrations of the car in movement. It consists of a spring, which is designed to deflect the vertical vibrations and a hydraulic damper, to deflect lateral vibrations of a car [1]. The dampers employed in automotive suspension are designed to perform symmetric damping characteristics in compression and rebound in order to achieve a better compromise between rides, road-holding, cushion, and handling and control performance of the vehicle. Considerably higher wheel velocity in the upward direction, when compared to that in the downward direction, the dampers provides significantly higher damping force in rebound. The non-linear and asymmetric damping properties of shock absorbers have been mostly characterized in terms of peak force-peak velocity characteristics. A number of suspension models based upon fluid flows through damper and valves, the suspension characterize the asymmetric force velocity characteristics. Since these models require prior knowledge of various coefficients to be derived from the measured data for a specific damper, their applications have been limited for analysis of vehicle ride and handling [2]. The spring stiffness,

K, of the spring on this shock absorber is 502 lb/in². The force generates by a spring, which moves a distance S away from its equilibrium position is given by the following equation:

$$F_{\text{spring}} = K \times S$$

A hydraulic damper dissipates an applied energy by pushing a hydraulic fluid through orifices in the piston and orifices at the bottom of the inner tube. When a force is applied to the damper the piston is moved down, pushing on the fluid. The fluid tries to squeeze through the orifices that are in the piston and also through the valves at the bottom of the inner tube and compresses the gas in the outer tube. The addition of forces required moving the fluid through the valves and the resisting force from the vehicle body with compression downward. This counteracting force is also called the damping force[1].The objective of this paper has been to design the conceptual model of double spring damper shock absorber, mathematically model a shock absorber and various analyses. The experimental tests have been done by placing a simulation of shock absorbers with various conditions. The results of these tests were then taken and analysed for the damping forces. Generally there are three types of vehicle suspensions were considered and modelled as

Papers presented in ICIREST-2018Conference can be accessed from

<https://edupediapublications.org/journals/index.php/IJR/issue/archive>

follows: oil damper mounted in parallel with a compression helical spring, for which a Kelvin-Voigt model, consisted of a dashpot and an elastic element connected in parallel is considered; colloidal damper without attached compression helical spring, for which a Maxwell model, consisted of a dashpot and an elastic element connected in series is considered; and colloidal damper mounted in parallel with a compression helical spring, for which a standard linear model, consisted of a Maxwell unit connected in parallel

with an elastic element is considered. The vibration transmissibility from the rough road to the vehicle's body for all these suspensions was determined under the constraint that damping varies versus the excitation frequency. Then, the optimal damping and stiffness ratios were decided in order to minimize the transmissibility of vibration from the rough pavement to the vehicle's body.³ This condition ideally achieved with new concept of double spring, damper shock absorber.

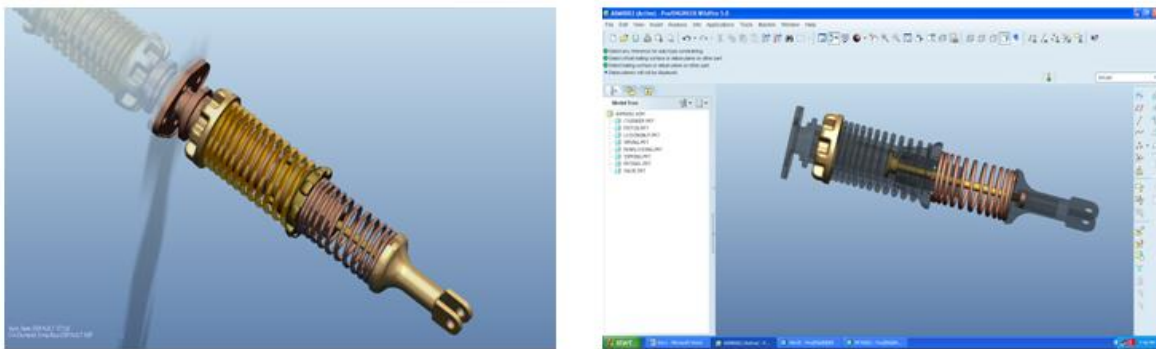

Fig 1.1 Double springs damper shock absorber modelling in pro-e w 5.0

II. METHODS TO ESTIMATE THE RIDE COMFORT

The vehicle's ride comfort is different from one passenger to another, depending on its taste and physical constitution. However, the ride comfort of a certain vehicle can be calculated based on the equivalent acceleration a_c which is proportionally depending on the root-mean-square of the weighted transfer function of vibration from the rough road to the vehicle's body [3], [4], [5].

$$a_c \propto \sqrt{\sum_i [F(f_i) |H(f_i)|]^2}. \quad (1)$$

The vibration transmissibility from the rough road to the vehicle's body for all these suspensions is determined under the constraint that damping varies versus the excitation frequency. Then, the optimal damping and stiffness ratios are decided in order to minimize the vibration transmissibility, Discrete frequency values of vibration transfer to vehicle are taken in the range 0.1–100 Hz, as follows: $f_i = 0.1, 0.125, 0.16, 0.2, 0.25, 0.315, 0.4, 0.5, 0.63, 0.8, 1, 1.25, 1.6, 2, 2.5, 3.15, 4, 5, 6.3, 8, 10, 12.5, 16, 20, 25, 31.5, 40, 50, 63, 80$ and 100 Hz. The so-called filter or weighting function $F(f_i)$ represents the vibration transfer function of the human body. For vibration transmitted in vertical direction from seat to the vehicle's rider, according to the K -factor method, the filter can be taken as [4].

$$F(f_i) = \begin{cases} 10^{(3f_i-15)/20}, & 0 \leq f_i \leq 4 \\ 10^{-3/20}, & 4 \leq f_i \leq 8 \\ 10^{(-0.75f_i+3)/20}, & f \geq 8 \end{cases} \quad (2)$$

On the other hand, according to ISO 2631 method, the frequency weighting can be introduced as [5]:



$$F(f_i) = \Gamma(f_i)\Delta(f_i) \frac{7.875f_i^2}{\sqrt{0.0256 + f_i^4}} \frac{10^4}{\sqrt{10^8 + f_i^4}}, \quad (3)$$

Where the functions $G(f_i)$ and $D(f_i)$ can be calculated as:

$$\Gamma(f_i) = \sqrt{\frac{f_i^2 + 156.25}{0.3969f_i^4 + 32.21875f_i^2 + 9689.94141}}, \quad (4)$$

$$\Delta(f_i) = \sqrt{\frac{0.8281f_i^4 - 3.68581f_i^2 + 26.1262}{0.8281f_i^4 - 7.36421f_i^2 + 104.29465}}. \quad (5)$$

In order to estimate the transfer function of vibration from the rough road to the vehicle's body, an adequate model should be adopted. In general, a vehicle with four wheels can be modelled as a system with 6 degrees of freedom (full-vehicle model [4], [5], [6]). However, when the frequency in vertical direction of the vehicle's body is below 2 Hz, it is possible to neglect the rolling and to assume that the left and right parts of the vehicle are identical (half vehicle model [6], [7]). Moreover, experience has proven that even if the pitching movement is neglected (quarter-vehicle model [6]), the ride-comfort can be predicted quite accurately. Accordingly, in this theoretical work, a quarter-vehicle moving on a rough pavement is considered as a suitable model to estimate the transmissibility and comfort.

III. MODELLING OF QUARTER CAR MODEL OF DOUBLE SPRING DAMPER SHOCK ABSORBER

In modelling the forces on the suspension of a car we can use a quarter car models, which focus on one wheel of the car for deriving the governing equations. As the first part of this project we focused on the behaviour of the suspension of a car and used a quarter car models to derive the governing equation. The following equation was derived using the free body diagram shown in Fig 3.1 below. It is the force summation around the wheel of a car in vertical direction, including the shock absorber. The input force to the system is the normal force from the road (i.e. F_n).

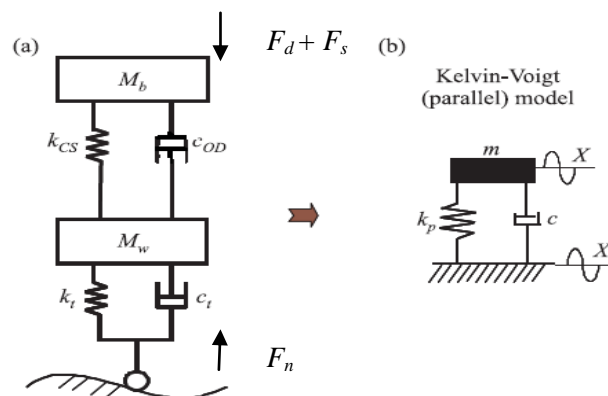

Fig 3.1 Modified Kelvin-Voigt quarter car shock absorber model3



$$\sum F = ma$$

$$-F_n + \gamma \frac{dS}{dt} + KdS + mg = m \frac{d^2 S}{dt^2}$$

In the above equation, F_n refers to the normal force from the road, g is the hydraulic constant, dS/dt is the velocity by which the shock absorber is moving, K is the spring constant, m refers to the portion of the weight of the car that is on one wheel of the car [1].

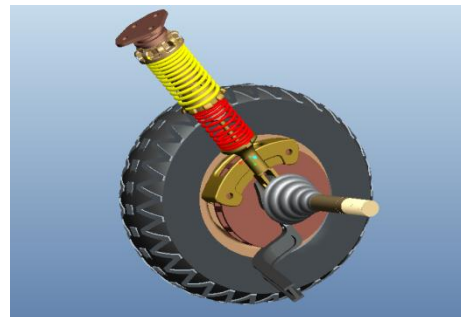
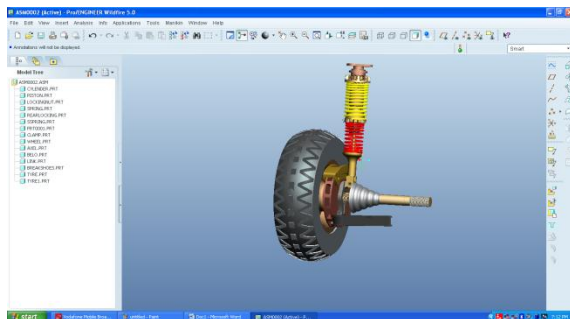

Fig 3.2 3D model complete assembly of double spring damper shock absorber in pro-e w 5.0

IV. THE METHOD TO MATHEMATICALLY MODEL AND SIMULATE THE SHOCK ABSORBER.

This model is produced using MATLAB Simulink and it simulates the behaviour of the shock absorber as various input forces are applied to it. The following are inputs and outputs of the program:

- Inputs:** - Force as function of time
 - Damping ratio's for different clicks (?)
 - Spring Constant (K)
 - Duration of time (t)

- Outputs:** -Graphs/values of $V(t)$
 -Graphs/values of $S(t)$.

It should be noted that an iterative approach has been taken to verify the shock absorber governing equation: the inputs to this program such as the force and the damping ratio are in fact the outputs from the experimental results of the MTS tests and the outputs of the program (velocity and displacement) are the inputs to the experiments. In other words, the experiment outputs were inputted into the program and after running the simulation the program outputs were compared with original experimental inputs. This method and the comparisons are fully described in the following sections. Before simulating the system, a mathematical model needs to be developed that represents the behaviour of the shock absorber. As mentioned before, this system is represented by a first order differential equation and in order to simulate it, a transfer function needs to be derived. The following presents the derivation of this transfer function:

$$F_{Applied} = \left(\gamma \left(\frac{dS}{dt} \right) + KS \right) \quad \text{let } S = x \quad F_{Applied} = \left(\gamma \left(\frac{dx}{dt} \right) + Kx \right)$$

Papers presented in ICIREST-2018Conference can be accessed from

<https://edupediapublications.org/journals/index.php/IJR/issue/archive>



$$F_{Applied} = (\gamma)(sx) + Kx \quad \text{—————} \quad F_{Applied} = (\gamma \cdot s + K)(x)$$

$$\therefore \frac{x}{F_{Applied}} = \frac{1}{(\gamma \cdot s + K)}$$

$$x = \frac{1}{(\gamma \cdot s + K)} \cdot F_{Applied}$$

The following block diagram Fig 4.1 presents the mathematical model of the shock absorber, which has been created in MATLAB Simulink. This model contains the transfer function that represents the behaviour of the shock absorber as its main block. As mentioned, the inputs include the force as a ramp function (compression or rebound) and as a sinusoid. The damping coefficient, spring constant and the duration of each cycle are other inputs to this program. The outputs are the displacement and the velocity.

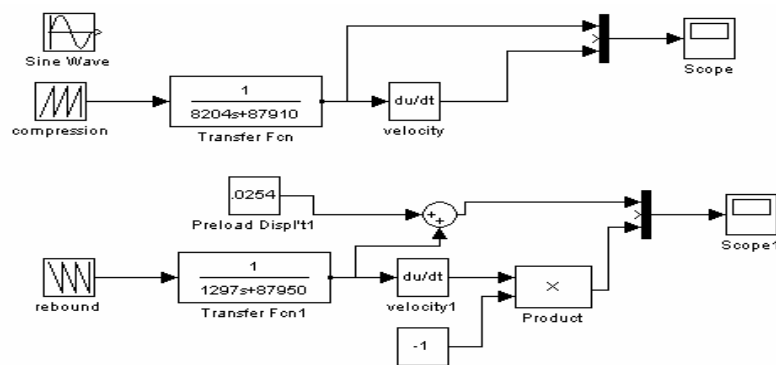

Fig 4.1 MATLAB Simulink block diagram for shock absorber

The following graphs Fig 4.2 illustrate an example of inputs and outputs of the simulation for the ramp function.

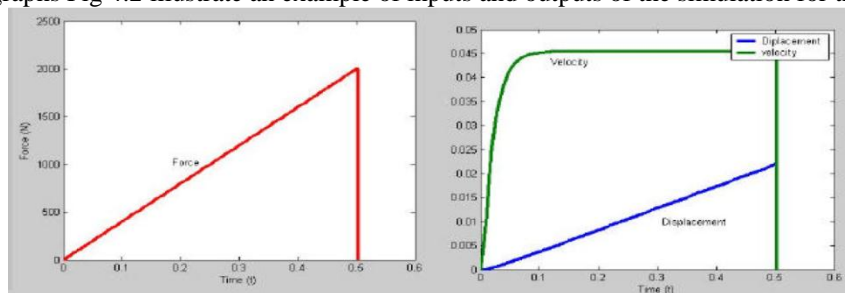

Fig 4.2 Ramp test simulation inputs and outputs

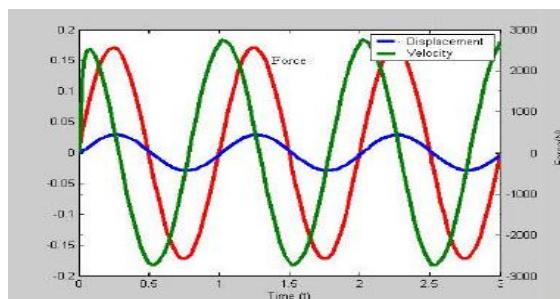

Fig 4.3 Sinusoidal test simulation inputs and outputs

V. CONCLUSION

In this work, design the conceptual double spring damper shock absorber types of suspensions were considered and modelled as follows: oil damper mounted in parallel with a compression helical spring, for which a Kelvin-Voigt model, consisted of a dashpot and an elastic element connected in parallel was considered; colloidal damper without attached compression helical spring, Firstly, the vibration transmissibility from the rough road to the vehicle's body for all these suspensions was determined under the constraint that damping varies versus the excitation frequency which evaluate simulation of shock absorber velocity and displacement. Then, the optimal damping and stiffness ratios were decided in order to minimize the transmissibility of vibration from the rough pavement to the vehicle's body with sinusoidal test in simulation , i.e., to maximize the vehicle's ride comfort with double spring damper shock absorber.

REFERENCES

- [1] S. Moradi Monfared, Mehrdad Ghods, Jeewan Bhanot Applied Science 330 (Intermediate Design) The University of British Columbia April 21, 2003
- [2] M.A.Jadhav, S.B. Belkar, R.R.Kharde Analysis of Displacement Sensitive Twin Tube Shock Absorber International Journal of Engineering Research and Development Volume 5, Issue 5 (December 2012), PP. 31-41

- [3] Claudiu Valentin Suci, Tsubasa Tobiishi, and Ryouta Mouri Modeling and Simulation of a Vehicle Suspension with Variable Damping versus the Excitation Frequency Journal of telecommunication and information technology. Volume 3 Issue 2 (January 2012) PP.42-41

- [4] S. Komamura, *Automotive Suspension*. Tokyo: Kayaba Technical, 2005 (in Japanese).

- [5] "Mechanical Vibration and Shock – Evaluation of Human Exposure to Whole-Body Vibration". ISO 2631-1, 1997.

- [6] A. Hac and I. Youn, "Optimal semi-active suspension with preview based on a quarter car model", *Trans ASME, J. Vibration Acoustics*, vol. 114, pp. 84–92, 1992.

- [7] A. Hac and I. Youn, "Optimal design of active and semi-active suspensions including time delays and preview", *Trans ASME, J. Vibration Acoustics*, vol. 115, pp. 498–508, 1993

Papers presented in ICIREST-2018 Conference can be accessed from

<https://edupediapublications.org/journals/index.php/IJR/issue/archive>