



Design Automation using Customization of CATIA V5

Mr. Neeraj Wayzode

Assistant Professor, Mechanical Engineering Department
 Tulsiramji Gaikwad-Patil College of Engineering and Technology, Nagpur

ABSTRACT

This paper, describe about how the customization (automation) of design task can be approached. This is explained by use of solid modeling software CATIA V5. The automation is done by means of macros (piece of code). This macros works in the environment of the windows operating system and with the visual basic as event driven programming. The user has to supply some basic design requirements of the coupling and rest of the data is calculated by formulas coded in the macros. Also, the design is checked for permissible stress limits as per the materials. If it is safe then with the help of these parameters, part model of is created. This part model can be used to draft various views of the coupling which can directly be used for manufacturing processes.

Keywords: Design, Customization, CATIA V5, Automation

1. INTRODUCTION

A coupling is termed as a device used to make permanent or semi- permanent connection where as a clutch permits rapid connection or disconnection at the will of the operator.

Couplings are used to connect two shafts for torque transmission in varied applications. It may be to connect two units such as a motor and a generator or it may be to form a long line shaft by connecting shafts of standard lengths say 6-8m by couplings. Coupling may

be rigid or they may provide flexibility and compensate for misalignment. They may also reduce shock loading and vibration. A wide variety of commercial shaft couplings are available ranging from a simple keyed coupling to one which requires a complex design procedure using gears or fluid drives etc. However there are two main types of couplings: **Rigid couplings** are used for shafts having no misalignment while the **Flexible couplings** can absorb some amount of misalignment in the shafts to be connected.

2. DESIGN OF COUPLING

Flange Coupling:

It is a very widely used rigid coupling and consists of two flanges keyed to the shafts and bolted. The two flanges are coupled together by means of bolts and nuts. The flange coupling is adopted for heavy loads and hence it is used for large shafting.

Consider a flange coupling as shown in figure

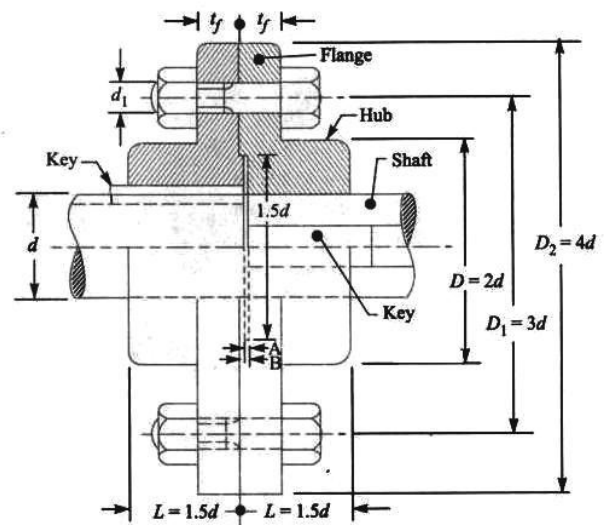

Papers presented in ICIREST-2018Conference can be accessed from

<https://edupediapublications.org/journals/index.php/IJR/issue/archive>



Fig 1: Flange Coupling

d = diameter of shaft or inner diameter of hub,
 D = outer diameter of hub,
 d_1 = Nominal or Outside diameter of bolt,
 D_1 = Diameter of bolt circle,
 n = number of flange,
 t_f = thickness of flange,
 τ_s, τ_b and τ_k = allowable shear stress for shaft, bolt and key material respectively.
 τ_c = allowable shear stress for flange material,
 σ_{cb} and σ_{ck} = allowable crushing stress for bolt and key material respectively.

The flange coupling is designed as discussed below:

2.1 Design of hub

The hub is designed by considering it as a hollow shaft, transmitting the same torque (T)

$$T = \frac{\pi}{16} \tau_c \frac{(D^4 - d^4)}{D}$$

as that of a solid shaft.

The outer diameter of hub is usually taken as twice the diameter of shaft. Therefore from the above relation, the induced shearing stress in the hub may be checked.

The length of hub (L) is taken as 1.5 d .

2.2 Design of key

The key is designed with usual proportions and then checked for shearing and crushing stresses. The material of key is usually the same as that of shaft.

2.3 Design of Flange

The flange at the junction of the hub is under shear while transmitting the torque.

Therefore, torque transmitted,

$$T = \text{Circumference of hub} \times \text{Thickness of flange} \times \text{shear stress of flange} \times \text{radius of hub}$$

$$T = \pi D \times t_f \times \tau_c \times \frac{D}{2} = \frac{\pi D^2}{2} \times \tau_c \times t_f$$

2.4 Design of Bolts

The bolts are subjected to shear stress due to torque transmitted. The number of bolts (n) depends upon the diameter of shaft and the pitch circle diameter of bolts (D_1) is taken as 3 d .

We know load on each bolt = $\frac{\pi}{4} (d_1)^2 \tau_b$

Total load on all bolts = $\frac{\pi}{4} (d_1)^2 \tau_b \times n$

and torque transmitted, $T = \frac{\pi}{4} (d_1)^2 \tau_b \times n \times \frac{D_1}{2}$

From this equation, the diameter of bolt (d_1) may be obtained. Now the diameter of bolt may be checked in crushing.

We know that area resisting crushing of all the bolts = $(n \times d_1 \times t_f)$

And crushing strength of all the bolts = $(n \times d_1 \times t_f) \sigma_{cb}$

Torque, = $(n \times d_1 \times t_f \times \sigma_{cb}) \frac{D_1}{2}$

With the help of Visual Basic programming and above equations we can obtain the required dimensions of a coupling for generating a three dimensional model in CATIA V5

3. CATIA V5

CATIA (Computer Aided Three dimensional Interactive Application) is a multi-platform CAD/CAM/CAE commercial software suite developed by French company Dassault Systems and it is marketed world-wide by IBM. CATIA is the world's leading CAD/CAM/CAE software. CATIA V5 is an



open system for developing advanced macros for special needs. A macro is a piece of code (written in a certain programming language) which groups a set of operations that define a certain task. These macros may be useful for creating, analyzing, measuring, modifying, translating, optimizing surfaces, solids, wireframes and more. Macros are also useful for assembly operations, CAM operations and all multidisciplinary applications. Macros are developed using VBScripts and VBA. In order to develop a macro in CATIA V5 all we need is the inputs, outputs and necessary supporting data from the user.

3.1 CATIA Customization/Automation Objects

In CATIA the part objects, which are used for developing part model i.e. three dimensional object are structured under a tree as shown in the following figure. As and when needed the part object can be extracted with the macro programming for customization or automation of CATIA V5

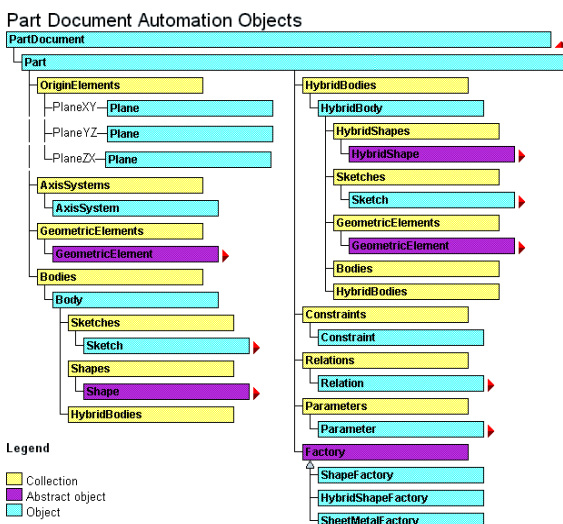

Fig 2: Part Modeling Object Tree

The **PartDocument** object aggregates, or includes, the part tree structure starting with the **Part object** located at the top of the part specification tree.

These **PartDocument** objects are: OriginElement, GeometricElements, Bodies and **Part objects** are: Constraints, Relations, Parameters, Factory3D, ShapeFactory (Sketches, GeometricElements, Shapes)

4. METHODOLOGY

Generation of Part Model

Part model is generated by few inputs given by designer. The designer has to select type of coupling, Material for coupling, input Power and Revolution. The parameters for coupling design are then calculated by the formulas, which is invoked by, calculate button on the main form. Also the design is checked whether it is safe or not, if it is safe, click on generate button. With this all design parameters are send to a subroutine to generate part model of Coupling. With this, part model of coupling is completed. If required the user can get different views of the coupling i.e. orthographic views along with isometric view for use while manufacturing.

The following figures gives an overview about how the customization of CATIA V5 looked

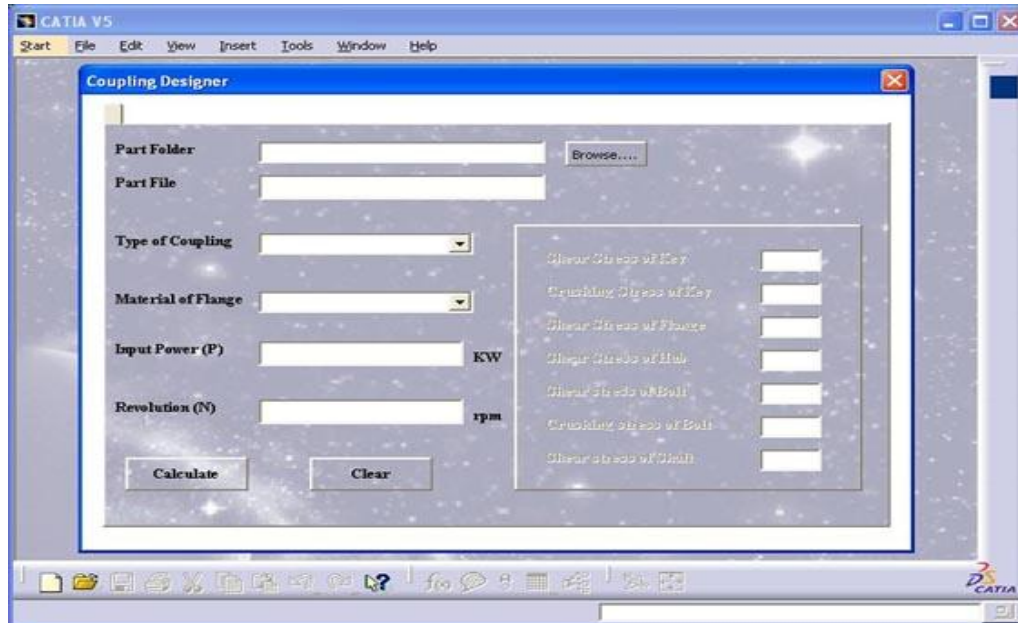

Fig 3: Input Parameter Form

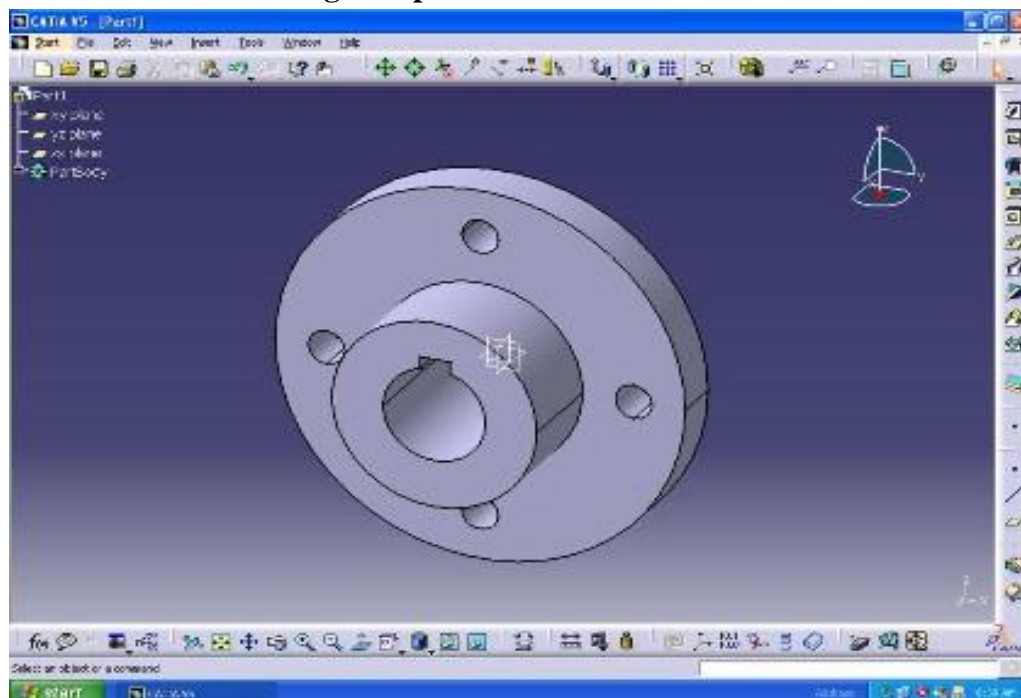

Fig 4: 3D View of Flange Coupling (Part Modeling)

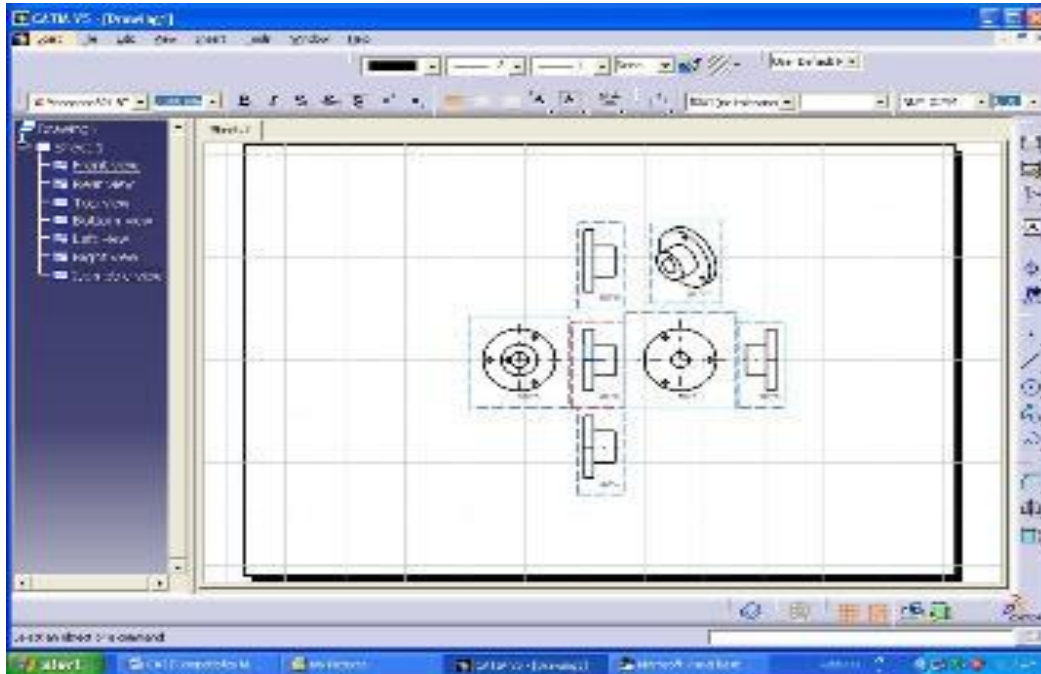

Fig 5: Drafted View of Flange Coupling

5. CONCLUSION

The objective was to customized CATIA V5 for design of a shaft coupling with minimum user requirements (inputs). With the help of this customization/automation a Coupling is generated. Also the time required for generating part model (three dimensional model) of Coupling is reduced to few minutes. This part model can be used to draft different views of the coupling which can directly be used for manufacturing processes. Thus, this automation / customization will increase productivity of the designer with increase in quality of design which in turn reduces lead time for design of shaft coupling.

Papers presented in ICIREST-2018Conference can be accessed from

<https://edupediapublications.org/journals/index.php/IJR/issue/archive>

6. REFERENCES

- [1] R.S.Khurmi & J.K.Gupta. Atextbook of Machine Design, S Chand Publications.
- [2] María Gloria Del Río-Cidoncha, Juan Martínez-Palacios, Francisco Ortuño-Ortiz, (2007),"Task automation for modelling solids with Catia V5", Aircraft Engineering and Aerospace Technology, Vol. 79 Iss: 1 pp. 53 - 59
- [3] Nathan Clark and Tom Schneider, "Working With the CATIA/Visual Basic Interface" Vought Aircraft Industries, Inc.
- [4] Adeyeri Michael Kanisuru, Adeyemi Michael Bolaji, Ajayi Olumuyiwa Bamidele & Abadariki Samson
- [5] Olaniran "Computer Aided Design of Couplings", International Journal of



International Journal of Research
eISSN: 2348-6848 & pISSN: 2348-795X Vol-5 Special Issue-13
International Conference on Innovation and Research in
Engineering, Science & Technology
Held on 23rd & 24th February 2018, Organized by Tulsiramji Gaikwad
Patil College of Engineering & Technology, Nagpur,
441108, Maharashtra, India.



- Engineering (IJE), Volume (5): Issue
(5): 2011 pp 313-332
- [6] Eric Bush, "Macro?... Polo! What
macros are and how they can help you"
Vought Aircraft Industries, Inc., 2009

[7] <http://www.maruf.ca/files/caadoc/CAAScdInfTechArticles/CAAINfInvoking.htm>