

Wireless Sensor Networks: An Energy Efficient Protocol Based on Hierarchical Routing Technique

Pardeep Nehra

Department of Computer Science
E-Mail:- par.nehra82@yahoo.com

ABSTRACT: *The area of wireless sensor networks (WSNs) is one of the emerging and fast growing fields in the scientific world. This has brought about developing low cost, low-power and multi-function sensor nodes. However, the major fact that sensor nodes run out of energy quickly has been an issue and many energy efficient routing protocols have been proposed to solve this problem and preserve the longevity of the network. This is the reason why routing techniques in wireless sensor network focus mainly on the accomplishment of power conservation. Most of the recent publications have shown so many protocols mainly designed to minimize energy consumption in sensor networks. This dissertation work proposes a hierarchical routing technique which shows energy efficiency. Our technique selects cluster head with highest residual energy in each communication round of transmission and also takes into account, the shortest distance to the base station from the cluster heads. Simulation results show that hierarchical routing technique with different level of hierarchy prolongs the lifetime of the network compared to other clustering scheme and the energy residual mean value after some communication rounds of simulation increases significantly.*

KEYWORDS: WSN, ADC, Information Technology, Routing Protocols.

INTRODUCTION:

Wireless Sensor Networks have emerged as new area in wireless technology. In the near future, the wireless sensor networks are expected to consist of thousands of inexpensive nodes, each having sensing capability with limited computational and communication power which enable us to deploy a large-scale sensor network. Due to recent technological advances, the manufacturing of small and low-cost sensors has become technically and economically feasible. These sensors measure ambient

conditions in the environment surrounding them and then transform these measurements into signals that can be processed to reveal some characteristics about phenomena located in the area around these sensors. A large number of these sensors can be networked in many applications that require unattended operations, hence producing a wireless sensor network (WSN). In fact, the applications of WSNs are quite numerous. For example, WSNs have profound effects on military and civil applications such as target field imaging, intrusion detection, weather monitoring, security and tactical surveillance, distributed computing, detecting ambient conditions such as temperature, movement, sound, light, or the presence of certain objects, inventory control, and disaster management. Deployment of a sensor network in these applications can be in random fashion (e.g., dropped from an airplane in a disaster management application) or manual (e.g., fire alarm sensors in a facility or sensors planted underground for precision agriculture). Creating a network of these sensors can assist rescue operations by locating survivors, identifying risky areas, and making the rescue team more aware of the overall situation in a disaster area.

Typically, WSNs contain hundreds or thousands of these sensor nodes, and these sensors have the ability to communicate either among each other or directly to an external base station (BS). A greater number of sensors allows for sensing over larger geographical regions with greater accuracy. Basically, each sensor node comprises sensing, processing, transmission, mobilizer, position finding system, and power units (some of these components are optional, like the mobilizer). Sensor nodes are usually scattered in a sensor field, which is an area where the sensor nodes are deployed. Sensor nodes coordinate among themselves to produce high-quality information about the physical environment. Each sensor node bases its decisions on its mission, the information it currently has, and its knowledge of its computing, communication, and energy resources. Each of these scattered sensor nodes has the capability to collect and route data either to other sensors or back to an external BS(s). A BS may be a fixed or mobile node capable of connecting the sensor network to an existing communications infrastructure or to the Internet where a user can have access to the reported data. In the past few years, intensive research that addresses the potential of collaboration among sensors in data gathering and processing, and coordination and management of the sensing activity was conducted. In most

applications, sensor nodes are constrained in energy supply and communication bandwidth. Thus, innovative techniques to eliminate energy inefficiencies that shorten the lifetime of the network and efficient use of the limited bandwidth are highly required.

Wireless Sensor Network: A sensor network is an infrastructure comprised of sensing (measuring), computing, and communication elements that gives an administrator the ability to instrument, observe, and react to events and phenomena in a specified environment. The administrator typically is a civil, governmental, commercial, or industrial entity. The environment can be the physical world, a biological system, or an information technology (IT) framework. Network(ed) sensor systems are seen by observers as an important technology that will experience major deployment in the next few years for a plethora of applications, not the least being national security. Typical applications include, but are not limited to, data collection, monitoring, surveillance, and medical telemetry. In addition to sensing, one is often also interested in control and activation.

Sensor nodes are scattered in a special domain called a sensor field. Each of the distributed sensor nodes typically has the capability to collect data, analyze them, and route them to a (designated) sink point. The components of a (remote) sensing node as shown in Fig. include the following:

- _ A sensing and actuation unit (single element or array)
- _ A processing unit
- _ A communication unit
- _ A power unit
- _ Other application-dependent units

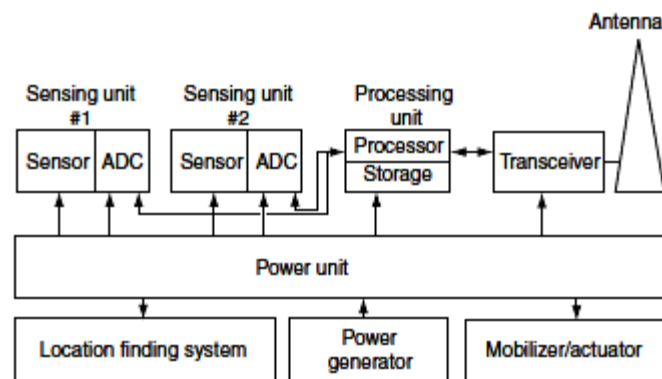

ADC = Analog-to-Digital Converter

Typical Sensing Node

OBJECTIVES:

Despite the innumerable applications of WSNs, these networks have several restrictions, such as limited energy supply, limited computing power, and limited bandwidth of the wireless links connecting sensor nodes. One of the main design goals of WSNs is to carry out data communication while trying to prolong the lifetime of the network and prevent connectivity degradation by employing aggressive energy management techniques. The design of routing protocols in WSNs is influenced by many challenging factors. These factors must be overcome before efficient communication can be achieved in WSNs.

Node deployment in WSNs is application-dependent and can be either manual (deterministic) or randomized. In manual deployment, the sensors are manually placed and data is routed through predetermined paths. However, in random node deployment, the sensor nodes are scattered randomly, creating an ad hoc routing infrastructure. Energy Consumption Without Losing Accuracy: Sensor nodes can use up their limited supply of energy performing computations and transmitting information in a wireless environment. As such, energy-conserving forms of communication and computation are essential. Transmission Media: In a multihop sensor network, communicating nodes are linked by a wireless medium. The traditional problems associated with a wireless channel (e.g., fading, high error rate) may also affect the operation of the sensor network. In general, the required bandwidth of sensor data will be low, on the order of 1–100 kb/s. Related to the transmission media is the design of MAC.

High node density in sensor networks precludes them from being completely isolated from each other. Therefore, sensor nodes are expected to be highly connected. This, however, may not prevent the network topology from being variable and the network size from shrinking due to sensor node failures. In addition, connectivity depends on the possibly random distribution of nodes. In WSNs, each sensor node obtains a certain view of the environment. A given sensor's view of the environment is limited in both range and accuracy; it can only cover a limited

physical area of the environment. Hence, area coverage is also an important design parameter in WSNs.

A REVIEW OF LITERATURE:

Various methods for minimizing energy consumption in wireless sensor network have been proposed such as described the LEACH protocol as a hierarchical self organized cluster based approach for monitoring application. The data collection area of the data is randomly divided into clusters. LEACH uses time division multiple access (TDMA), to transmit data from the sensor nodes to the cluster head. Then CH aggregates the data and transmits it to the base station for processing. One of the features of LEACH is localized coordination and control for the formation and operation of clusters. The cluster head rotate randomly. It eliminates the overhead of dynamic cluster formation created by LEACH. In this protocol, the nodes transmit to the CH and transmission of data is done by the cluster head, which is selected in a rotational manner, to the BS. PEGASIS protocol is found to save more energy and is more robust in node failure when compared to LEACH. Developed a protocol that creates clusters of the similar size and uses multi-hop routing between CH and the BS. The cluster head which forward the last hop is selected randomly from the sets of cluster heads to minimize the load of cluster head which are located nearest to the base station. In Wei Li proposed a geometric programming model to extend the network lifetime of the sensor network by clustering sensor nodes into groups. He developed an iterative method for solving the geometric programming by choosing the optimal location of cluster heads. The optimum mentioned in his proposition refers to minimizing energy consumption based on to inter-sensor network under specific constrained. Clustering of approaches is useful in the monitoring of habitat and environs. This however, necessitates the use of continuous stream of sensor data. It propose DDBC (Directed Diffusion Based on Clustering). DDBC is an energy-efficient directed diffusion routing protocol which is based on the reduction of the network topology and gives suppression to the redundancy message in plain flooding in order to minimize energy consumption in wireless sensor network. He gave a description of a contention based medium access protocol, S-MAC, which minimizes energy consumption in wireless sensor network by using virtual clusters. They

developed the common sleep schedule for the clusters and overhearing is avoided by the use of in-channel signaling. He proposed a novel adaptive, distributed, energy efficient clustering algorithm, AEEC for wireless sensor network. Their approach selects cluster heads based on the node energy related to that of the whole network which can bring about efficiency in heterogenous networks. It also made a survey of the routing technique in wireless sensor network and mentioned that hierarchical routing technique has the advantages related to scalability and efficient communication.

Routing Protocols in WSN					
Flat network routing		Hierarchical network routing		Location based routing	
Protocol	Power Usage	Protocol	Power Usage	Protocol	Power Usage
SPIN	Ltd.	LEACH	Max.	GAF	Ltd.
DD	Ltd.	TEEN & APTEEN	Max.	GEAR	Ltd.
REEP	Max.	PEGASIS	Max.	LEGR	Max.
CADR	Ltd.	NSEEAR	Max.		
COUGAR	Ltd.	MECN & SMECN	Max.		
EADD	Ltd.	TTDD	Ltd.		

CONCLUSION: It can be proved that the proposed hierarchical routing technique offers when compared to the non-hierarchical routing. We investigated the advantage of the proposed technique by comparing the time in which the first node dies during the 400 rounds of simulation (network lifetime) to that of the non-hierarchical routing technique. We observed that the first node dies faster in the non-hierarchical formation since all nodes tend to send captured data via one randomly selected cluster

head per round to the base station. The constrained load on the elected cluster heads during the 400 round of simulation drastically reduced the CHs' energy over a short period. The impressive increment in life span of the network from our proposed hierarchical technique is seen as a result of efficient routing decision and optimization of energy in cluster head selection of each cluster formed. Since the sensor nodes in each cluster send data to the cluster head within its cluster range and then the aggregated data is sent to the cluster head closer to the base station, which further aggregates data of its own cluster and that of the incoming data, from cluster head whose distance is farther to the BS, before sending the data to the base station. Thus, a considerable amount of energy is saved which indicate improved network lifetime in the case of first level hierarchy when compared to non hierarchical technique. We observed that the Non-hierarchical technique had an estimated lifetime of 10 rounds, First level hierarchical technique had an estimated lifetime of 110 rounds and Second level hierarchical technique had an estimated lifetime of 130 rounds. The progressive increase of network lifetime employed by our proposed technique offers efficient energy usage for each node in the entire network. Also, it was observed that the Non-hierarchical technique network completely stopped functioning at an earlier simulation rounds compared to our proposed technique. We saw that the functional capacity for Non-hierarchical network lasted till an estimated value of 120 rounds of simulation, while the functional capacity of the First level Hierarchical approach and Second level hierarchical approach lasted till an estimated value of 180 rounds and 330 rounds of simulation. Furthermore, we also observed in With this increase, the WSN's lifetime was further prolonged when compare to the two cluster formation and the non hierarchical technique.

REFERENCES:

1. R. Draves, J. Padhye, and B. Zill, (2004), Routing in Multi-Radio, Multi- Hop Wireless Mesh Networks, Proc. ACM MobiCom, Sept./Oct.
2. T. Goff, N. Abu-Ahazaleh, D. Phatak and R. Kahvecioglu, (2001), Preemptive Routing in Ad Hoc Networks, Proc. ACM MobiCom,
3. Y.C. Hu and D.B. Johnson,(2002), Design and Demonstration of Live Audio and Video over Multi-Hop Wireless Networks, Proc. Military Comm. Conf.



4. Seattle Wireless,(2009), <http://www.seattlewireless.net>.
5. Rozner E,Seshadri J,Mehta Y A and Qiu L ,(2009), SOAR: Simple Opportunistic Adaptive Routing Protocol for Wireless Mesh Networks, Volume-8, Issue.12:1622-1635.
6. I.F. Akyildiz, W. Sue, Y. Sankarasubramaniam, and E. Cayirci, (2002), A Survey on Sensor Networks IEEE Comm. Magazine, Vol. 40, Issue. 8:102-114.
7. T. Melodia, D. Pompili, and I.F. Akyildiz,(2004), Optimal Local Topology Knowledge for Energy Efficient Geographical Routing in Sensor Networks, Proc. IEEE INFOCOM, Volume.3,Issue 1705-1716.
8. T.S. Rappaport, A. Annamalai, R.M. Buehrer, and W.H. Tranter, (2002), Wireless Communications: Past Events and a Future Perspective, IEEE Comm. Magazine, Volume. 40,Issue.5:148-161.