

Accident Notification System

Supriya C Shetty , Aysha Shahistha , Sabeera Abida Ayisha , Rufaida Shoukat Ali , Kavyashree

¹²³⁴Shree devi institute of technology

⁵Asst Professor, Computer Science and Engineering Shree Devi Institute of Technology,kenjar,Mangalore

supriyacshetty1996@gmail.com , ayshashahistha34@gmail.com , ayishasabira682@gmail.com ,
rufaida013@gmail.com , Kavya16.naik@gmail.com

Abstract-This paper presents review on the accident detection techniques and some future possibilities in this field. Now-a-days lots of accidents happen on highways due to increase in traffic and also due to rash driving of the drivers. And in many situations the family members or the ambulance and police authority is not informed in time. This result in delaying the help reached to the person suffered due to accident. Road accidents constitute the major part of the accident. The purpose of the project is to find the vehicle where it is and locate the vehicle by means of sending a message using a system which is placed inside of vehicle system Most of the times we may not be able to find accident location because we don't know where accident will happen. Our project Real Time Vehicle Tracking and Accident Detection with GPS is designed to avoid such situations.

Keywords-Global Positioning System(GPS),Esp8266, Arduino Nano, Impact sensor,IR sensor .

1. INTRODUCTION

Now-a-days lots of accidents happen on highways due to increase in traffic and also due to rash driving of the drivers. And in many situations the family members or the ambulance and police authority is not informed in time. This result in delaying the help reached to the person suffered due to accident. Our project Real Time Vehicle Tracking and Accident Detection with GPS is designed to avoid such situations. Road

2. LITERATURE SURVEY

The Rapid growth of technology and infrastructure has made our lives easier. The advent of technology has also increased the traffic hazards and the road accidents take place frequently which causes huge loss of life and property because of the poor emergency facilities. This paper will provide an optimum solution to this draw back. This paper presents vehicle accident detection and alert system with SMS to the user defined mobile numbers. The GPS tracking and gateway alert based algorithm is designed and implemented with Arduino Nano in embedded system domain. The proposed Vehicle accident detection system can track geographical information automatically and sends an alert SMS regarding accident. Experimental work has been carried out carefully. The result shows that higher sensitivity and accuracy is indeed achieved using this project. EEPROM is interfaced to store the mobile numbers

accidents constitute the major part of the accident. Our project Real Time Vehicle Tracking and Accident Detection with GPS is designed to avoid such situations.

Transportation has great importance in our daily life and its development has made many of our chores much easy. But it can cause disaster to us and even can kill us through accidents. During 2008, Road Traffic Injuries ranked fourth among the leading causes of death in the world. Nearly 1.3 million people die every year on the world's roads and 20 to 50 million people suffer non-fatal injuries, with many sustaining a disability as a result of their injury.

The purpose of the project is to find the vehicle where it is and locate the vehicle by means of sending a message using a system which is placed inside of vehicle system. Most of the times we may not be able to find accident location because we don't know where accident will happen. In order to give treatment for injured people, first we need to know where the accident happened through location tracking and sending a message to your related one or to the emergency services. So in this work we are using the basic microcontroller AT89S52 for cost effective and also for easy understanding. Here we used assembly programming for better accuracy and GPS and gateway which helps to trace the vehicle anywhere on the globe. The exact location of the vehicle is sent to our remote devices (mobile phones) using gateway

permanently. This made the project more user-friendly and reliable.

This paper proposes a new dimension in order to allow early response and rescue of accident victims; saving lives and properties. Proposed system uses the capability of GPS and gateway along with the android phone to provide a solution which can be used to precisely detect the accident spot and to send the emergency notification to the nearby hospital's ICU and to the victim's relatives Sensors and the switches/other components used in system is distributed throughout the car hence provides more flexibility while mounting into the vehicle. Using the open source android adds another advantage as we can work on top of some already built APIs for GPS and gateway interfacing hence decreasing the total project completion time. Overall the system performance is increased.

In highly populated Countries like India, everyday people lose their lives because of accidents and poor emergency facilities. These lives could have been saved if medical facilities are provided at the right time. This paper implies system which is a solution to this drawback. Accelerometer sensor can be used in car security system to sense vibrations in vehicle and GPS to

give location of vehicle, so dangerous driving can be detected Automatic accident detection and reporting system is designed in this paper. When accident occurs, it is sensed by Accelerometer. Short message including location of accident obtained using GPS, is sent via gateway network. It provides more than 70% safety for four wheelers.

3. PROPOSED IMPLEMENTATION

System design

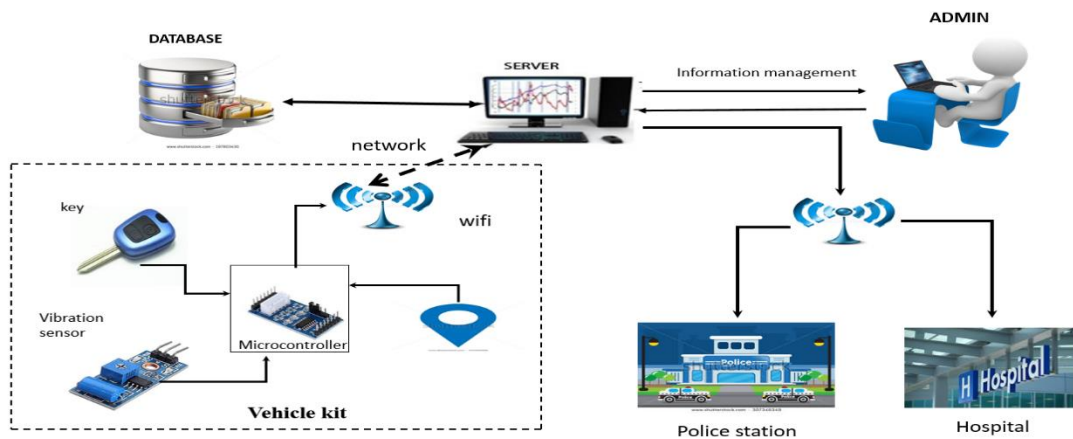

Fig3.1.The complete architectural design of proposed system.

Description

We are using AT89S52 microcontroller in our system. When the system is switched on, LED will be ON indicating that power is supplied to the circuit. When the PUSH ON SWITCHES that we are using in our system sense any obstacle,

they send interrupt to microcontroller. The GPS receives the location of the vehicle that met with an accident and gives the information back via RS232. This information will be sent to a mobile number through a message. This message will be received using gateway modem present the circuit. The message will give the information of longitude and latitude values. Using these values the position of the vehicle can be estimated.

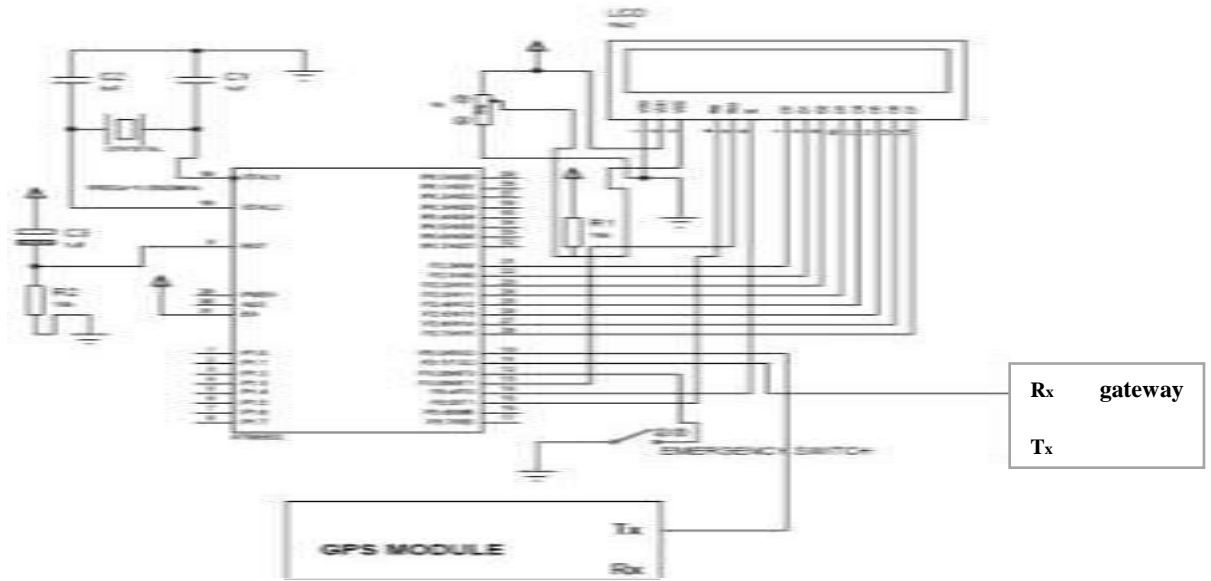

Fig.3.2.Circuit Diagram

Hardware used

1.

Microcontroller

We are using AT89S52 controller. When PUSH ON SWITCHES senses the obstacles, they send signal to interrupt pin of microcontroller. It operates on AT commands.

2.LCD

16x2 LCD is used. LCD displays latitude and longitude values of location.

3.GPS

GPS satellite transmits data that indicates its location and the current time. GPS continuously sends latitude and longitude values to microcontroller.

4.GATEWAY

wifi is used, it receives co-ordinates from microcontroller and sends message to mobile number store in our system.

Software used

1.Eagle

In our project, we are using EAGLE (Easy Applicable Graphical Layout Editor) software for PCB designing. Eagle is easy to used, flexible, easy to learn.

2.Keil

The keil software is design to solve the complex problems facing embedded software developers. Microcontroller operates on hex commands. Keil compiler is very good for converting hex commands into machine language.

Working

In this project we are going to use an accident detection unit which will be fitted inside the front and rear bonnet of the car. This accident detection unit consists of PUSH ON SWITCHES. In case of accident, if the car is hit to some other vehicle or an object then PUSH ON SWITCHES senses obstacles and send

signal to interrupt pins of microcontroller. Microcontroller is the central processing unit CPU of our project. Once microcontroller gets signal from push on switches, then it will immediately turn on the buzzer. A key will be provided for the driver. If the accident is very normal, or driver has hit the wall in some situations like parking then driver will press the key. This will inform the microcontroller that this is a very normal

accident. But if driver is not in situation to press the switch or if the accident is really a major accident then driver will not press the key. Then microcontroller will get the coordinates from the GPS modem then it will send this information to the gateway, gateway is used to send this information via SMS. SMS will be sent to the family member of the driver, so that they can take immediate action to help the persons suffering due to this accident.

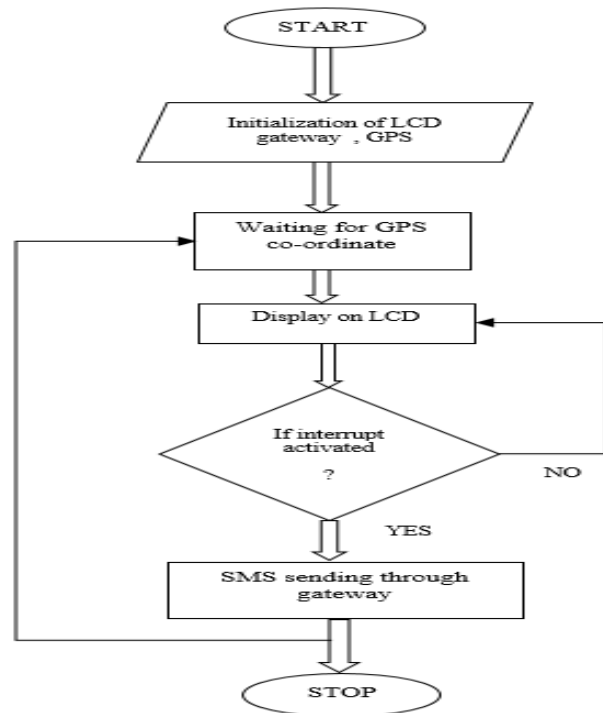

Fig 3.3.Flow Chart

4. ADVANTAGES& APLLICATIONS

Advantages

1. Easy to detect the exact location of the vehicle.
2. It provides security to the vehicle in very reasonable cost.
3. Intelligent high-tech safety system.
4. It saves the precious time required to save the accident victims.

Applications

1. Used in automotive and transport vehicles from lighter vehicles like cars, to heavier automotive like ships and aero planes.
2. Security and remote monitoring of vehicles especially during military operations.
3. This system is also can be interfaced with Vehicle airbag system such that when the sensors detect the accident, the air bags get opened.
4. School transport vehicle accident detection.
5. This project can be used for cab or car of companies.

5. CONCLUSION & FUTURE SCOPE

Conclusion

In this project, we have successfully designed vehicle accident detection and tracking system by using gateway and GPS. When accident occurs, it senses by PUSH ON SWITCHES. The coordinates of location of accident obtained by GPS, are sent via gateway network to user defined mobile number. It is the fact that implementation of system will increase cost of vehicle but it is better to have some percent safety rather than having no percent of safety.. The proposed method is verified to be highly beneficial for the automotive industry. The proposed system can also be used for traffic estimation and accidents survey in the country by health department with slight modification.

Future scope

1. This system can be interfaced with vehicle airbag system that prevent vehicle occupant from striking interior objects such as the steering wheel or window.
2. This can also be developed by interconnecting camera to controller module that takes the photograph of the accident spot that makes the tracking easier



REFERENCE

[1] THE 8051 MICROCONTROLLER AND EMBEDDED SYSTEMS by muhammed ali mazidi and Janice gillispieMazidi,pearson Education.

[2] AUTOMATIC VEHICLE ACCIDENT DETECTION AND MESSAGING SYSTEM USING GSM AND GPS MODEM by C Prabha , R Sunitha, R Anitha, IJARFFIF 7,July 2014.

[3] CAR ACCIDENT DETECTION SYSTEM USING GPS,GSM AND BLUETOOTH by Vikram singh, Kushwaha, Deepa Yadav, IJERGS May-June 2015.

[4] VEHICLE ACCIDENT DETECTION AND REPORTING SYSTEM USING GPS AND GSM by Aboli Ravindra Wakure, Apoorva Rajendra Patkar, IJERGS April 2014.