

A Hybrid Multilevel Inverter by Using Diode Clamped and Cascaded H-Bridge Inverter Topologies

¹P.VENKATA RAMA KRISHNA ²V.SUNITHA

¹Assistant Professor, Dept. Of EEE, Mother Theresa Institute of Engineering & Technology, Palamaneru, AP.

²PG Scholar, Dept. Of EEE, Sree Vidyanikethan Engineering College, Tirupati, AP.

ABSTRACT:

A novel multilevel inverter topology with reduced number of power switches is proposed. A multilevel inverter is a power electronic device that is used for high voltage and high power applications of low switching stresses and lower total harmonic distortion, hence reduces the size and bulk of passive filters. This new topology is based on a combination of conventional diode clamped and H-bridge topologies. The proposed idea has not only achieves high power ratings but also enables the use of renewable energy source. It dramatically reduces the switching losses; cost and low order harmonics and thus effectively improves total harmonic distortion. A 15 level inverter will be simulated with the implementation of PWM techniques and its effects on the harmonics spectrum will be. The system will be modified with the help of MATLAB/Simulink.

Keywords: multilevel inverter, harmonic content, diode clamped, H-bridge.

1. INTRODUCTION:

Multilevel inverter provides a suitable solution for medium and high power systems to synthesize an output voltage which allows a reduction of harmonic content in voltage and current waveforms. Renewable energy power supplied into the utility grid has been paid much attention due to increase in fossil fuel prices, environmental pollution and energy demand boom. Among various renewable energy resources such as solar, wind, tidal, geothermal, biomass etc., the solar photovoltaic system being more attractive and promising green resource. The solar photovoltaic (PV) modules directly converts the light energy into the electrical energy, but energy obtained from the PV module acts as low voltage DC source and has relatively low

conversion efficiency. In order to improve the efficiency and convert low voltage DC source into usable AC source, the power electronics converters are used to transform DC into AC. The simulation results presented in this paper verifies the operation of proposed MMC topology.

1.1. INVERTER:

Inverter is an electronic device that changes DC source to AC source. The input voltage, output voltage and the overall power handling depend on the design of specific circuitry. The inverter does not produce any power, the power is provided by the DC source. It is widely used in industrial and domestic application.

1.2. MULTILEVEL INVERTER:

The MLI (multilevel inverter) is a type of inverter circuit which is used to increase the efficiency of the inverter operation and reduce the THD level in the operation of inverter. In order to reduce the losses we also reduce the number of switch used in the circuit. The pulse width modulation technique is used to get the desired output.

2. DIODE CLAMPED TOPOLOGY:

This topology was first proposed in 1981. They are also known as neutral point. As the name suggest, and unlike cascaded H-bridge inverters, they need clamping devices. Diodes are used as clamping devices. Three phase diode clamped multilevel inverter have three legs with a common DC bus. This Dc voltage is subdivided into switches via capacitors. For n-levels, n-1 switches are required. For n-levels, n-1 capacitors are required for clamping Dc voltages. If one switch is turned on, the other one from the pair should be necessarily off. Each diode has to block the voltage equal to number of switches above it times the supplied DC voltage.

3. H-BRIDGE TOPOLOGY:

The term H bridge is derived from the typical graphical representation of such a circuit. An H bridge is built with four switches (solid-state or mechanical). One of the basic and well known topologies among all multilevel inverter is cascaded H-bridge multilevel inverter. It can be used for both single and three phase conversion.

4. PROPOSED SYSTEM:

In this proposed system we proposed new multilevel inverter with reduced number of switches and the switching losses is also get reduced and level is increased up to 9 or 15 level with reduced (THD). In order to obtain a dc voltage of 0 Hz, we have to use a low pass filter. So that a capacitive filter circuit is used where a capacitor is connected at the rectifier output and a dc is obtained across the filtered waveform is essentially a dc voltage with negligible ripples & it is ultimately fed to the load. The driver circuit forms the most important part of the hardware unit because it acts as the backbone of the inverter AS it gives the triggering pulse to the switches in the proper sequence. The driver unit contains the following important units.

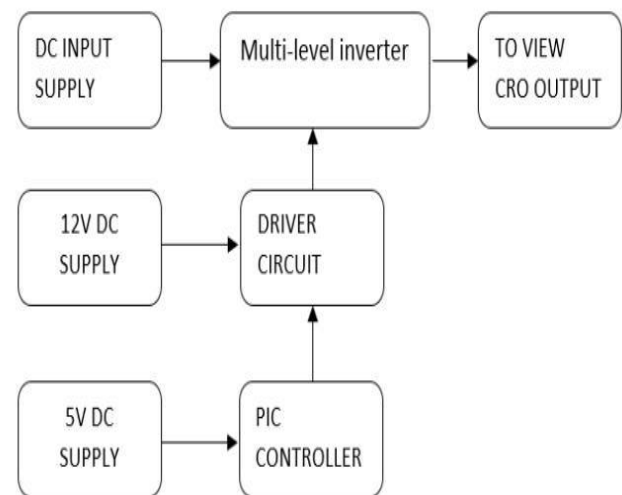

Fig.1. Block diagram of MLI

In conventional approach, PWM techniques are used by the comparison of reference and carrier signals to provide the required gating signals for the inverter switches. The number

of output voltage levels obtained from this approach is given in the following equation: $m = 2N_s + 1$ where m denotes the output voltage levels and N_s is the individual inverter stages. The number of switches (l) required to achieve m levels is given in the following equation: $l = 2(m - 1)$ For the implementation of 15-level CMLI, the number of switches required is 28 with seven individual inverter stages. In addition to the 28 switches, 182 clamping diodes in case of NPC or diode clamped multilevel inverter and 91 balancing capacitors in case of FC type multilevel inverter along with 14 DC bus capacitors are needed to achieve 15-level output. The proposed paper deals with the following topologies for the reduction of switches. Increasing the number of levels will subsequently reduce the harmonic distortion which in turn improves the power quality. Most of the existing multilevel topologies claim to reduce total number of device count. This objective can be misleading since the devices used in a multi-level inverter vary significantly in terms of their costs and complexities. Diodes and capacitors are cheap, and offer an easy placement in printed circuit boards. On the other hand, power switches are expensive, and a careful implementation of transistor gate drivers is required for their operation. Additional elements, snubbing network, and resonant circuits may also be required in some applications of these power switches. Based on that, an optimization for the reduced number of total device count as carried out

may be misleading and less useful when one goes for a practical implementation. Instead, it appears more prudent to target a reduced number of switches only, when we seek an optimum implementation of multi-level inverters.

5. CIRCUIT DIAGRAM:

The circuit diagram of 15 level multilevel inverter using both diode clamped and H-bridge topologies is shown in Fig 1. The resistive load is connected across the H bridge connected switches. Here we use mosfet as switching device.

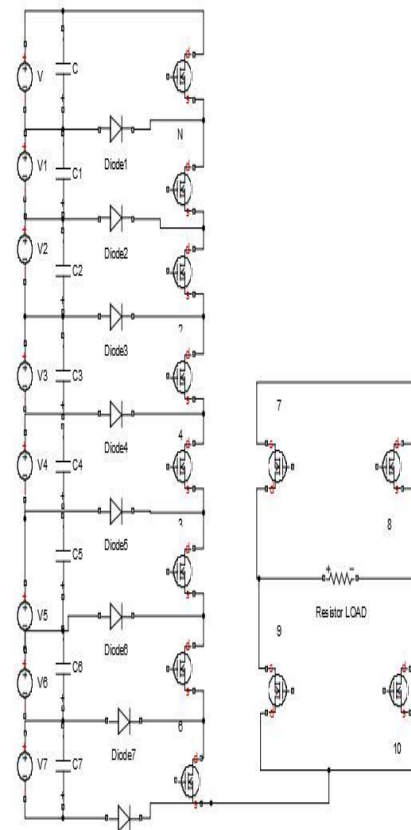

Fig.2.Circuit Diagram of 15 level MLI

6. SIMULATION:

6.1 SIMULATION DIAGRAM:

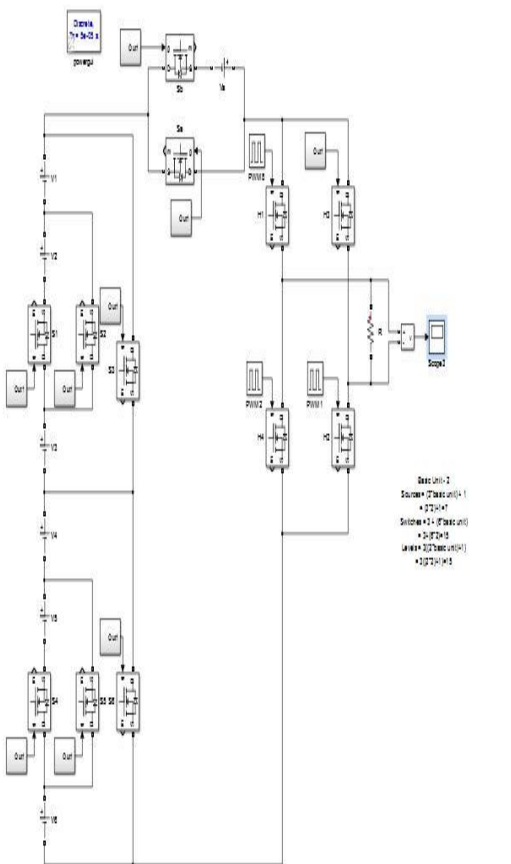

Fig.3. simulation circuit of 15 level MLI

6.2 SIMULATION RESULTS:

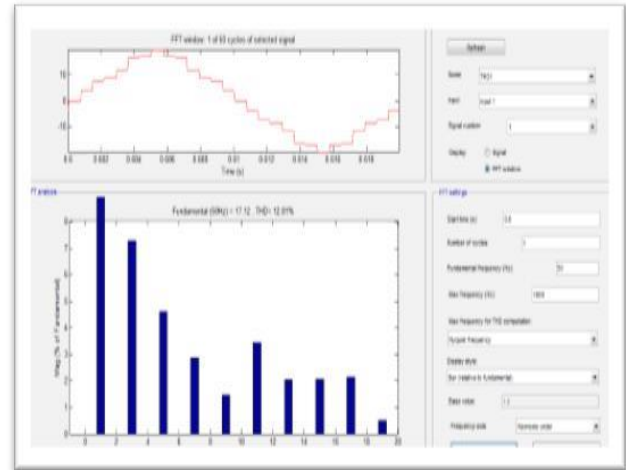
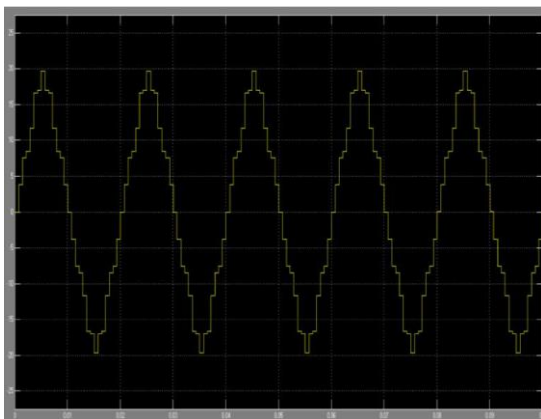

Fig.5 THD in output waveform

7. CONCLUSION:

A multilevel inverter with individual dc sources has been proposed for use in large electric drives. Simulation and experimental results have shown that with a control strategy operates the switches at the fundamental frequency; these converters have low output voltage THD and high efficiency. In summery the main advantages of using multilevel converters for large electric drives include the following,

They are suitable for large volt-ampere rated and /or high voltage motor drives.

1. These multilevel converters systems have higher efficiency because the devices can be switched at minimum frequency.
3. No EMI problem or common mode voltage/current problem exists.
4. No charge unbalance problem results when the converters are in higher charge mode or drive mode.

REFERENCES:

1. Nagaraj vinoth kumar, “MULTILEVEL INVERTER TOPOLOGY”, *journal of engineering* , vol3, 2017.
2. R.saravananandP.Amanoharan, *etall.:* “MULTILEVEL INVERTER BASED UPQC”, *,ind adv eng tech* ,vol 7, jan 2016.
3. Manoj kumar and mamta singh, “An improved pso based selective harmonic elimination In multilevel inverter” ,*IJEDR*, vol 3, 2015.
4. E. Babaei, S. Laali, and S. Alilu, “Cascaded multilevel inverter with series connection of novel H-bridge basic units”, *Ind. Electron. IEEE Trans.*, vol. PP, no.99, p.1, Dec. 2014.
5. Ned Mohan, Power Electronics first Course. Wiley, 2012.
6. S. Kouroand, “Recent advance sand industrial applications of multilevel converters”,*Ind. Electron.*, vol. 57, no. 8, pp. 2553–2580, Aug. 2010.

ABOUT AUTHOR



**P. VENKATA RAMA
KRISHNA, Assistant
Professor.**