

Implementation of Energy Management of Power for various types of Grid connected Systems

G.Krishnaiah

M.Tech (Digital Systems and Computer Electronic)

Abstract: *The passive generators are usually wind energy conversion systems. The fluctant wind conditions the grid requirement generated power not depends. This paper describes the dc-wind /hydrogen /super capacitor hybrid power system and the purpose of the control system is to coordinate these different sources. Particacally their power exchange ,in order to make the controllable the generated power. An active wind generator can be built to provide some ancillary services to the grid are the results in this paper. The control system should be adapted to integrate the power management strategies..Two power management stratgesis are presented and compared experimentally. We executed that the source following strategy has better performance on the grid power regulation than the grid following strategy.*

Keywords: Distributed power, energy management, hybrid power system (HPS), power control, wind generator (WG).

I. INTRODUCTION

The fast boom within the call for electric powered power requires the extra installation of electricity capacities. The energy capacities from fossil fuels were extraordinarily consumed and their reserves have been swiftly depleted compared to the opposite sources. Consequently, there is currently a focal point on renewable strength usage and improvement as appropriate opportunity electricity. Among the renewable sources wind, solar and fuel cells are developing insignificance and benefit the hobby of energy researchers. After the 1980s, the fee of power supplied by using wind energy has been extensively dropping. These cost discounts are because of new technology, more green, and extra dependable wind generators. Renewable energy sources (RES) have been attracting special attention all over the world since decades because of the following reasons:

1. Reduces dependency on imported fossil fuels.
2. Reduction of emission of the green house gases.
3. secured energy supply at all the times.

The low efficiency and high cost are the main drawbacks of RES. There is no proper control over the produced electrical power in case of Wind generators, Photovoltaic panels. If they are integrated without proper control strategies, they may lead to grid instability or even failure of grid, which ultimately may lead to total collapse of the system. Hence it is necessary to achieve stable active, reacting power at the generators. The electrical system must provide some ancillary service when connected to a micro grid. A hybrid power system with energy storage system and good power management strategies can be a solution [1-4]. Energy storage systems are used to compensate or absorb the difference between the generated wind power and the required grid power so that active, reactive powers are controlled. These are long term Energy storage systems including Hydrogen technologies, combining fuel cells (FCs) and electrolyzers (EL). Power management strategies are implemented to control the power exchange among different sources and to provide some services to the grid. They also provide ancillary services to the grid. According to researchers, wind electrolysis is a very attractive candidate for an economically viable renewable hydrogen production system [5], [6]. Hydrogen, as an energy carrier, contributes directly to the reduction of dependence on imported fossil fuel [7], [8]. Flywheel systems are also suitable for fast-dynamic energy storage [9], [10]. However, this mechanical system is currently hampered by the danger of —explosive shattering of the massive wheel due to overload (tensile strength because of high weight and high velocity). SCs are less sensitive in operating temperature than batteries and have no mechanical security problems.

Figure (1) shows the scheme of the studied system with common DC/ common AC collection buses interface. The scheme uses a primary common DC bus collection with an added secondary common AC bus for feeding any AC loads and public grid interface. The proposed hybrid green energy scheme is digitally simulated for different operation conditions and load

excursions. The developed control scheme comprises novel multi-loop coordinated dynamic error driven controllers with supplementary regulation loops to control the different subsystems [6,7].

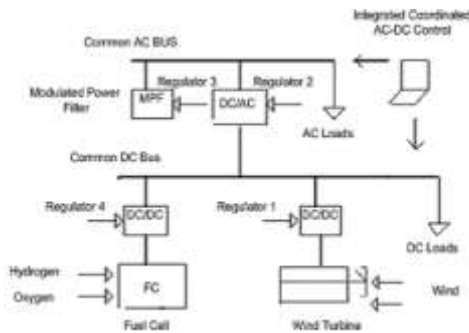

Fig. 1 Integrated (Wind-FC) Green Energy Utilization Scheme for Village Electricity

II. HYBRID POWER SYSTEM (HPS) AND CONTROL SYSTEM

A. Structure of HPS

In this paper a DC coupled structure is used to decouple the grid voltages and frequencies from other sources. All sources are connected to main DC bus before being connected to the main grid inverter (fig 2). Every source is electrically connected with a power electronic converter to get the best possible power control actions. The HPS structure and its global control system can be used for various combinations of sources

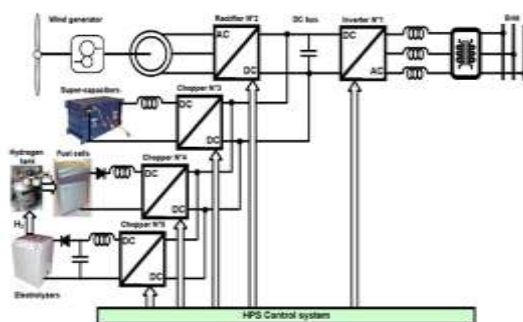

Fig 2. Structure of the studied wind/hydrogen/SCHPS

B. Structure of Control system

Power converters introduce some control inputs for power conversion. In this paper, the structure of the control system can be divided into different levels Fig. 3.

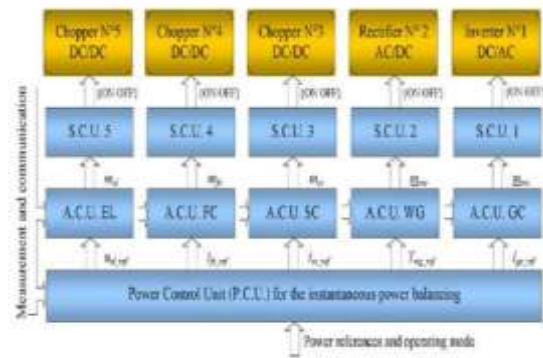

Fig.3.Hierarchical control structure of the HPS

The switching control unit (SCU) is designed for each power converter. In an SCU, the drivers with opto couplers generate the transistor's ON/OFF signals from the ideal states of the switching function $\{0, 1\}$, and the modulation technique (e.g., pulse width modulation) determines the switching functions from the modulation functions (m).

The automatic control unit (ACU) is designed for each energy source and its power conversion system. The ACU consists of control algorithms to calculate the modulation functions (m) for each power converter according to their reference values. The power control unit (PCU) is designed to perform the instantaneous power balancing of the entire HPS in order to satisfy the grid requirements. These requirements are real- and reactive-power references, which are obtained from the secondary control center and from references of droop controllers. In a PCU, some power-balancing algorithms are implemented to coordinate the power flows of different energy sources. The control schemes in the ACUs are shown in Fig. 4 with block diagrams.

- 1) The EL power conversion system is controlled by setting the terminal voltage equal to a prescribed reference through the dc chopper N°5. The EL stack is considered as an equivalent current source.
- 2) The FC power conversion system is controlled with a reference of the FC current through the dc chopper N°4. The FC stack is considered as an equivalent voltage source.
- 3) The SC power conversion system is controlled with a current reference through the dc chopper N°3. The SC bank is considered as an equivalent voltage source.

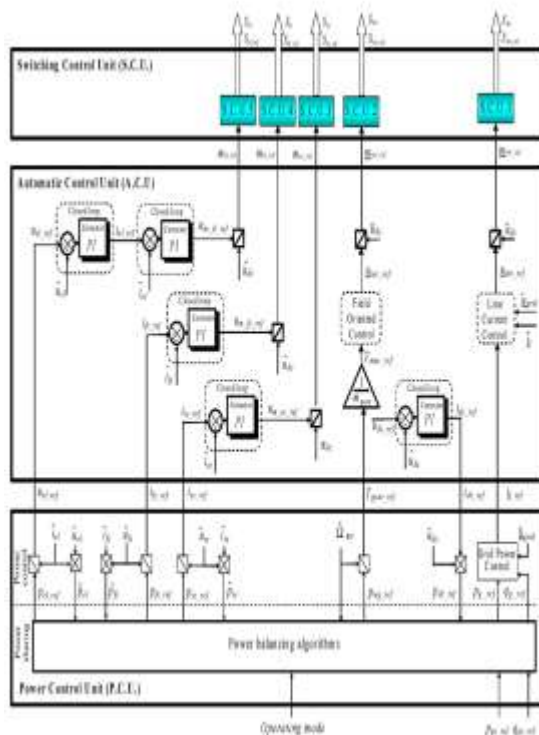

Fig 4. Modeling and control of the HPS by the Energetic Macroscopic Representation

4) The wind energy conversion system is controlled with a reference of the gear torque by the three-phase rectifier N°2.

5) The grid connection system consists of a dc-bus capacitor and a grid power conversion system. The grid power conversion system is controlled with line-current references by the three-phase inverter N°1, because the grid transformer is considered as an equivalent voltage source .

III. PCU

the PCU is also divided into two levels: the power control level and the power sharing level (Fig. 5). The power sharing level coordinates the power flow exchanges among the different energy sources with different power -balancing strategies.

A.Power Control Level:

To achieve maximum amount of power from wind energy conversion system, maximum power point tracking system is used.

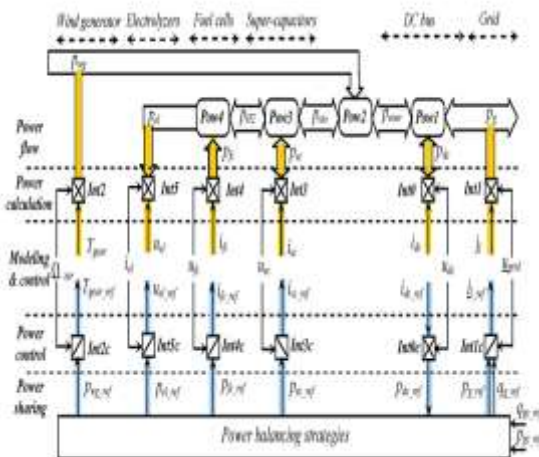

Fig 5 Multilevel representation of the power modeling and control of the HPS

The maximal-power-point- tracking (MPPT) strategy extracts the maximum power of the available wind energy according to a nonlinear characteristic in function of the speed.

In this wind/hydrogen/SC HPS, five power-electronic converters are used to regulate the power transfer with each source. According to a chosen power flow, the following two power balancing strategies can be implemented.

- 1) The grid-following strategy uses the line-current loop to regulate the dc-bus voltage.
- 2) The source-following strategy uses the line-current loop to control the grid active power, and the dc-bus voltage is regulated with the WG and storage units.

IV. POWER BALANCING STRATEGIES

A. Grid-Following Strategy:

With the grid-following strategy, the dc-bus voltage is regulated by adjusting the exchanged power with the grid, while the WG works in MPPT strategies. In steady state, the dc-bus voltage is regulated, and the averaged power exchange with the dc-bus capacitor can be considered as zero. Hence, in steady state, the grid power (p_g) is equal to the total power from the sources (p_{sour}). In order to help the wind energy conversion system respect the active -power requirement, the energy storage systems should be coordinated to supply or absorb

the difference between this power requirement (P_{gc_ref}) and the fluctuant wind power (P_{wg}).

B. Source-Following Strategy:

The total power (P_{sour}) from the energy storage and the WG can also be used to provide the necessary dc power (P_{dc}) for the dc-bus voltage regulation. Therefore, the HPS can directly supply the required powers for providing the ancillary services to the microgrid, like the regulations of the grid voltage and frequency.

V. SIMULATION RESULTS

Matlab simulation is carried out for both strategies, grid, source respectively).

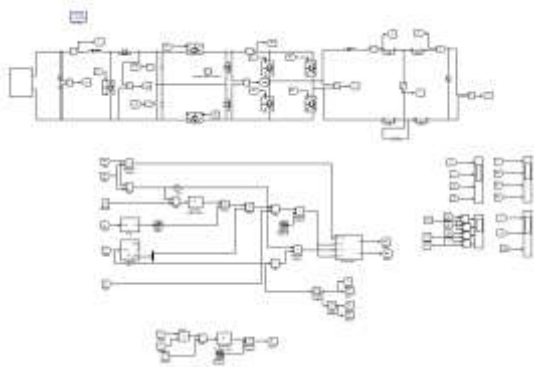

Fig 6 Simulink model

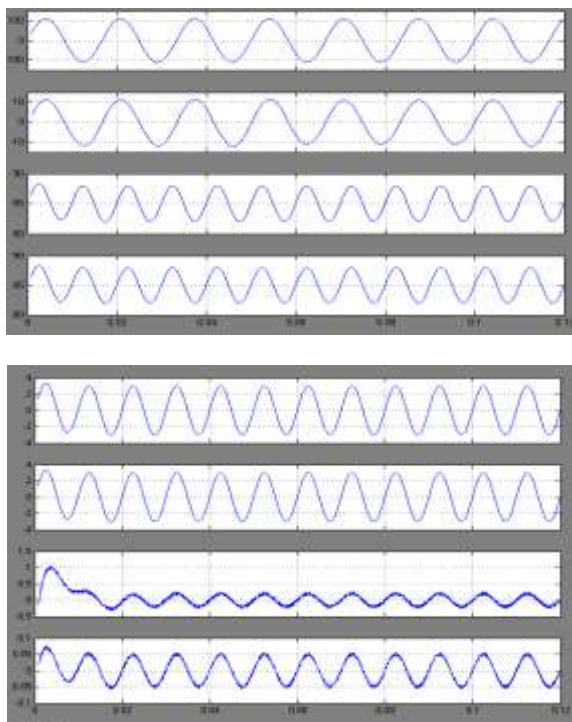

Fig 7 Power profiles of the different sources.

The active-power requirement from the microgrid is assumed to be $P_{gc_ref} = 600W$. Similar power profiles are obtained for the energy storage systems (Fig. 7). When the generated wind power is more than 600 W, the EL is activated to absorb the power difference, but when the generated wind power is less than 600 W, the FC is activated to compensate the power difference.

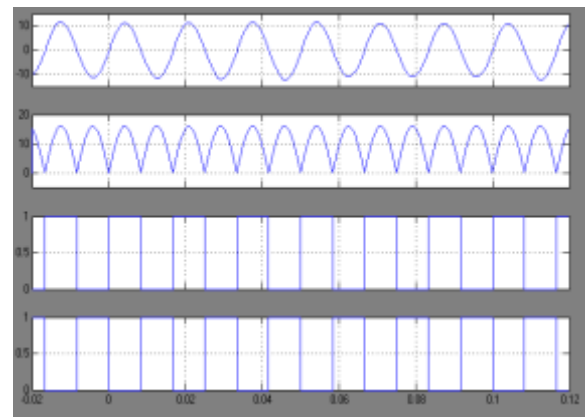

Fig 8

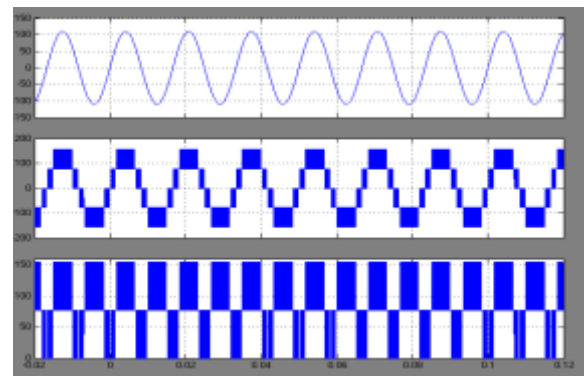

Fig 9

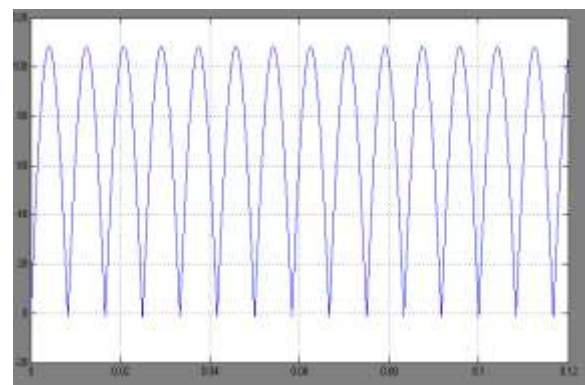

Fig 10

V. CONCLUSION

In this proposed scheme a DC coupled HPS has been studied with the three kinds of source s: 1)WG generator (WG), including three kinds of sources:

- 1) a RES: WG;
- 2) a fast-dynamic storage: SCs; and 3) a long-term storage: FC, EL, and H2 tank.

The two energy management strategies the grid following and the source following are presented The Dc bus voltage is well regulated with source following strategy. The simulation results shows that he with the introduction of energy storage system, better control over the active and reactive power is observed. With the encouraging results for the grid connected sources, non conventional energy sources will be utilized frequently. Hence with proper energy balancing and power control strategies grid following or source following strategies can be used. With further advances in technologies, SC's can be made less sensitive in operating temperature than batteries and have no mechanical security problems.

REFERENCES

- 1) J. M. Guerrero, J. C. Vasquez, J. Matas, M. Castilla, and L. G. de Vicuna, "Control Strategy for flexible micro grid based on parallel line-interactive UPS systems, IEEE Trans. Ind. Electron, vol. 56, no. 3, pp. 726–736, Feb. 2009.
- 2) C. Sudipta, D. W. Manoja, and M. G. Simoes, "Distributed intelligent energy Management system for a single-phase high-frequency AC micro grid," IEEE Trans. Ind. Electron, vol. 54, no.1, pp. 97–109, Feb. 2007.
- 3) D. M. Vilathgamuwa, C. L. Poh, and Y. Li, "Protection of micro grids during utility voltage sags," IEEE Trans. Ind. Electron., vol. 53, no. 5, pp. 1427–1436, Oct. 2006
- 4) M. Prodanovic and T. C. Green, —"High-quality power generation through distributed control of a power park micro grid" IEEE Trans. Ind. Electron., vol. 53, no. 5, pp 1427–1436, Oct. 2006
- 5) R. M. Dell and D. A. J. Rand, —Energy storage "A key technology for global energy sustainability," Power Sources, vol. 100, no. 1/2, pp. 2–17, Nov. 2001.
- [6] Mohamed A. H. El-Sayed, Adel M. Sharaf, "An Efficient Hybrid Wave/Photovoltaic Scheme for Energy Supply in Remote Areas" , accepted for publication in international journal of Renewable Energy Technology.
- [7] H. Fargali, F. Fahmy, M. A. El-Sayed, "Control and optimal sizing of PV-Wind powered rural zone in Egypt" Al-Azhar Engineering 10 th International conference, Cairo, Dec. 24-26, 2008.
- 8) M. Lebbal, T. Zhou, B. Francois, and S. Lecoeuche, "Dynamically electrical modeling of electrolyzers and hydrogen production regulation," in Proc Int. Hydrogen Energy Congr. Exhib., Istanbul, Turkey, Jul. 2007.

BioData



G. Krishnaiah completed M.Tech (Digital Systems and Computer Electronic).