

Design and Analysis of C.I. Engine Combustion Chamber Using CFD

Gopi Kuncham & Shaik Hussain

¹ M_tech student (Thermal Engineering) Department of Mechanical Engineering, Malla Reddy Engineering College(Autonomous), HYD, INDIA.

² Associate professor , Department of Mechanical Engineering, Malla Reddy Engineering College (Autonomous),HYD, INDIA.

ABSTRACT: *Internal combustion engines are visible every day in vehicles, trucks, and buses. The name inner combustion refers additionally to fuel turbines besides that the name is commonly carried out to reciprocating inner combustion (I.C.) engines like the ones determined in everyday automobiles. There are basically sorts of I.C. Ignition engines, those which need a spark plug, and those that rely upon compression of a liquid. Spark ignition engines take a aggregate of fuel and air, compress it, and ignite it the usage of a chambers. f, the combustion chamber model is designed spark plug.*

In this work an attempt is made to analyse two types of combustion chambers. The base line combustion chamber is compared with the modified combustion chamber. For design of combustion chamber Creo software is used and for the analysis part ANSYS CFD is used. The performance and emission parameters like pressure, velocity, mass fraction of O₂, mass fraction of N₂ and heat transfer coefficient are determined. The obtained results of modified combustion chamber are optimum.

INTRODUCTION

The diesel engine (additionally called a compression-ignition or CI engine), named after Rudolf Diesel, is an internal combustion engine wherein ignition of the fuel that is injected into the combustion chamber is because of the expanded temperature of the air in the cylinder because of mechanical compression (adiabatic compression). Diesel engines paintings through compressing best the air. This will increase the air temperature within the cylinder to one of these high degree that atomized diesel gas this is injected into the combustion chamber ignites spontaneously. This contrasts with spark-ignition engines along with a petrol engine (gas engine) or fuel engine (using a gaseous gasoline rather than petrol), which use a spark plug to ignite an air-gas combination. In diesel engines, glow plugs (combustion chamber pre-warmers) may be used to resource starting in cold weather, or whilst the engine uses a lower

compression-ratio, or both. The original diesel engine operates on the "constant pressure" cycle of gradual combustion and produces no audible knock.

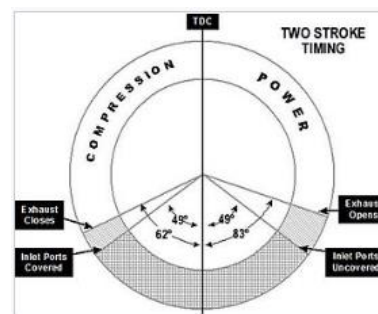

Detroit Diesel timing

OPERATING PRINCIPLE

The diesel inner combustion engine differs from the fuel powered Otto cycle by the use of quite compressed warm air to ignite the gasoline in place of the use of a spark plug (compression ignition in place of spark ignition).

In the genuine diesel engine, only air is to start with delivered into the combustion chamber. The air is then compressed with a compression ratio commonly among 15:1 and 23:1. This excessive compression reasons the temperature of the air to upward push. At about the top of the compression stroke, fuel is injected at once into the compressed air in the combustion chamber. This can be right into a (generally toroidal) void within the top of the piston or a pre-chamber relying upon the layout of the engine. The gas injector guarantees that the gas is broken down into small droplets, and that the gas is distributed flippantly. The warmth of the compressed air vaporizes gas from the surface of the droplets.

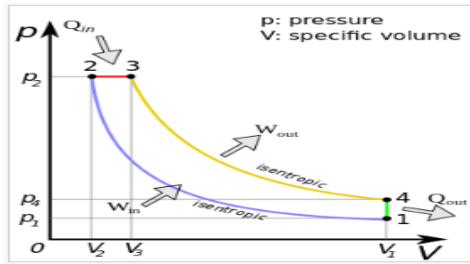

MAJOR ADVANTAGES

Diesel engines have several advantages over other inner combustion engines:

- Diesel gasoline has higher electricity density and a smaller volume of gasoline is needed to carry out a specific amount of labor.
- Diesel engines inject the gasoline without delay into the combustion chamber, have no intake air restrictions apart from air filters and intake plumbing and haven't any consumption manifold vacuum to feature parasitic load and pumping losses as a consequence of the pistons being pulled downward towards intake machine vacuum. Cylinder filling with atmospheric air is aided and volumetric efficiency is elevated for the equal cause.
- Diesel fuel has better lubrication properties than petrol as well. Indeed, in unit injectors, the gasoline is employed for three distinct functions: injector lubrication, injector cooling and injection for combustion.

INDIRECT INJECTION

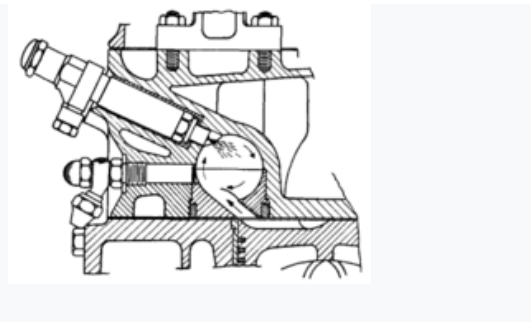

Ricardo Comet indirect injection chamber

An indirect diesel injection device (IDI) engine delivers gas right into a small chamber referred to as a swirl chamber, pre combustion chamber,

pre chamber or ante-chamber, that is linked to the cylinder by using a narrow air passage. Generally the aim of the pre chamber is to create accelerated turbulence for higher air / fuel mixing. This device additionally permits for a smoother, quieter running engine, and due to the fact gasoline mixing is assisted with the aid of turbulence, injector pressures may be decrease. Most IDI structures use a single orifice injector. The pre-chamber has the disadvantage of decreasing performance because of improved heat loss to the engine's cooling gadget, proscribing the combustion burn, therefore lowering the efficiency by using 5–10%. IDI engines are also more difficult to start and generally require using glow plugs. IDI engines can be inexpensive to build but typically require a better compression ratio than the DI counterpart. IDI also makes it less complicated to supply smooth, quieter running engines with a simple mechanical injection system due to the fact exact injection timing isn't as important. Most modern car engines are DI which have the advantages of more efficiency and easier beginning; but, IDI engines can still be observed in the many ATV and small diesel applications.

DIRECT INJECTION

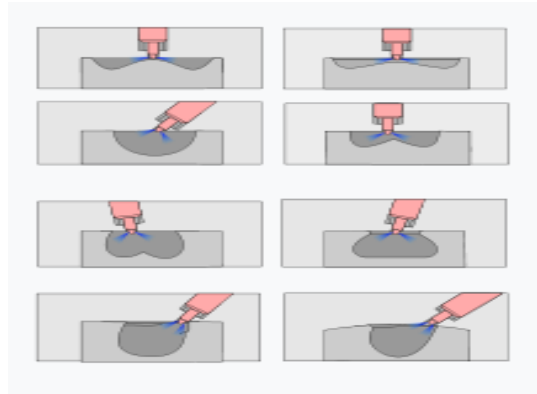

Different varieties of piston bowls

Direct injection diesel engines inject gas immediately into the cylinder. Usually there is a combustion cup within the top of the piston wherein the gasoline is sprayed. Many specific strategies of injection can be used.

EMISSIONS

Since the diesel engine makes use of less gasoline than the petrol engine in line with unit distance, the

diesel produces much less carbon dioxide (CO₂) according to unit distance. Recent advances in production and adjustments inside the political climate have expanded the availability and cognizance of biodiesel, an alternative to petroleum-derived diesel gasoline with a much decrease net-sum emission of CO₂, because of the absorption of CO₂ by way of vegetation used to supply the gas. However, the use of waste vegetable oil, sawmill waste from controlled forests in Finland, and advances in the production of vegetable oil from algae demonstrate excellent promise in providing feed shares for sustainable biodiesel that aren't in competition with food production.

II. PROBLEM DESCRIPTION

In this thesis, the combustion chamber is designed in step with the IC engine specifications and analyzed for its heat switch price the use of Finite Element analysis software ANSYS and calculate emissions .

Modeling will be completed in CREO parametric software. CFD analysis to determine the pressure drop, speed and heat transfer coefficient and to finding the emissions (O₂, N₂) of methane and ethane (mass fraction, mole fraction and mole awareness of methane and ethane).

III. LITERATURE REVIEW

[1] Combustion Chambers in CI Engines: A Review Arka Ghosh B. Tech. (Mechanical Engineering), SRM University, Kattankulathur, T.N., India – 603203 CI engines are widely utilized in desk bound as well as cell programs. Stationary applications consist of typical gen-set, etc. And cellular applications consist of heavy cars, forestry equipments, etc. As well as different programs in day-to-day existence. Since the turbulence is important for better mixing and the reality that it could be controlled via form of the combustion chamber, makes this evaluation paper necessary. This paper re-visits and attracts on the necessities of combustion chamber, their design, have an effect on in combustion procedure, timing, and so forth. This paper is supposed to emphasise studies on newer designs requirement for combustion chambers. CI engines discover huge packages due to their robustness, high compression ratio and for this reason high thermal efficiency and usage of non-volatile gasoline typically diesel oil.

INTRODUCTION TO CAD

Computer-aided layout (CAD) is the usage of pc systems (or workstations) to resource in the introduction, change, analysis, or optimization of a design. CAD software program is used to growth the productivity of the fashion designer, improve the best of design, improve communications thru documentation, and to create a database for production. CAD output is often within the form of digital files for print, machining, or different manufacturing operations. The time period CADD (for Computer Aided Design and Drafting) is likewise used.

INTRODUCTION TO CREO

PTC CREO, previously called Pro/ENGINEER, is 3D modeling software used in mechanical engineering, layout, production, and in CAD drafting service companies. It became one of the first three-D CAD modeling programs that used a rule-based totally parametric machine. Using parameters, dimensions and features to seize the conduct of the product, it could optimize the improvement product in addition to the layout itself.

Input parameter of CFD domain

Parameter	Magnitude
Crank shaft speed	1550 rpm
Crank radius	56 mm
Bore	85 mm
Stroke	85 mm
Fuel	Diesel C ₁₀ H ₂₆

MODELING

The geometry of the C.I engine is modeled in CREO3.0 software.

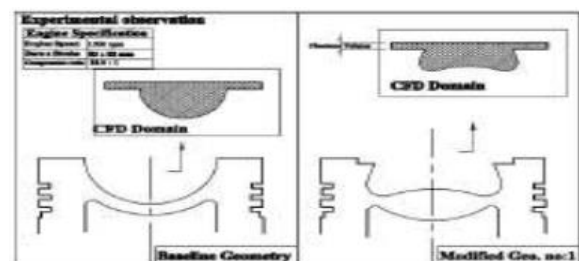

ORIGINAL MODEL

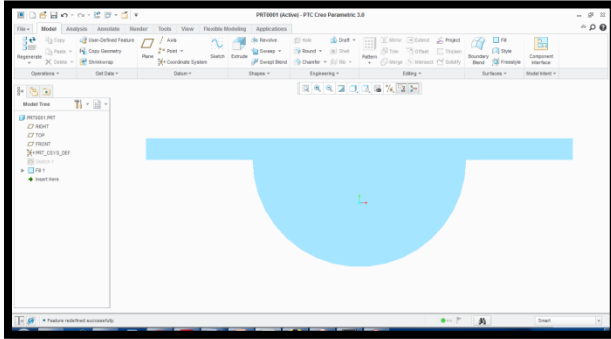

Original model of combustion chamber

Draw a required combustion chamber profile that should be in closed loops then its convert into 3D surface by using fill option.

MODIFIED

MODEL

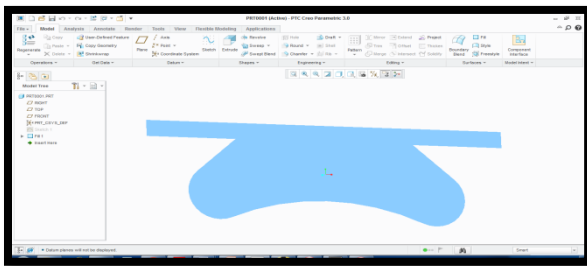

Draw a required combustion chamber profile that should be in closed loops then its convert into 3D surface by using fill option.

INTRODUCTION TO FEA

Finite detail analysis is a technique of solving, typically about, sure troubles in engineering and technology. It is used specifically for problems for which no genuine solution, expressible in a few mathematical form, is available. As such, it's far a numerical in preference to an analytical approach. Methods of this kind are wanted due to the fact analytical techniques cannot cope with the real, complex troubles that are met with in engineering. For instance, engineering electricity of materials or the mathematical concept of elasticity may be used to calculate analytically the stresses and traces in a bent beam, however neither will be very a hit in locating out what is going on in part of a vehicle suspension device for the duration of cornering.

CFD ANALYSIS OF COMBUSTION CHAMBER

Computational method and Boundary situation

For CFD evaluation viscous popular k-e RNG fashionable version is enabled for considering volumetric reaction and eddy dissipation. Domain is subjected to movement of piston appropriate boundary situation for piston, cylinder, fluid and cylinder walls. Combustion manner in a C.I engine involves the brief injection of finely atomized liquid fuel into the air at excessive temperature and pressure. Boundary condition area of the injector, length of the injector, injection temperature and pressure, mass flow rate are having vast effect in diesel combustion modeling. The injection mass waft charge parameters and Engine specs are given underneath Table 1 Engine specification Parameter Magnitude Engine Speed 1550 rpm Mass Flow Rate 0.00111055 kg/s Spray Cone Angle 55 Deg. Start Crank Angle 360 Deg. Stop crank Angle 720 Deg.

Parameter	Magnitude
Engine Speed	1550 rpm
Mass Flow Rate	0.00111055 kg/s
Spray Cone Angle	55 Deg.
Start Crank Angle	360 Deg.
Stop crank Angle	720 Deg.

Imported model

The geometry of the C.I engine is modeled in CREO software. that file is converted into IGES format to import in ANSYS software. The model of combustion chamber is saved in IGES format which can be directly imported into ANSYS workbench. The model imported to ANSYS workbench

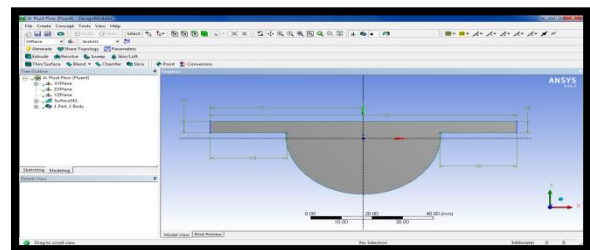

Imported CFD domain combustion chamber original model shows in fluid flow fluent

Meshed model

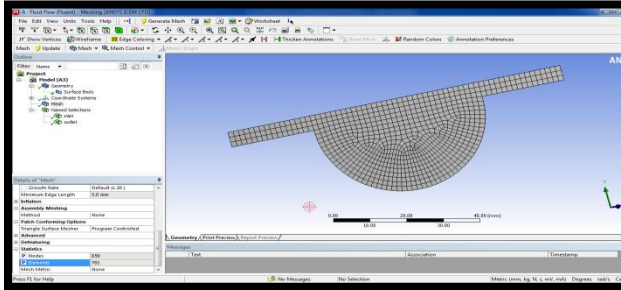

The meshing is done on the model with 859 number of nodes and 781 numbers of tetrahedral elements.

Inlet and outlet conditions

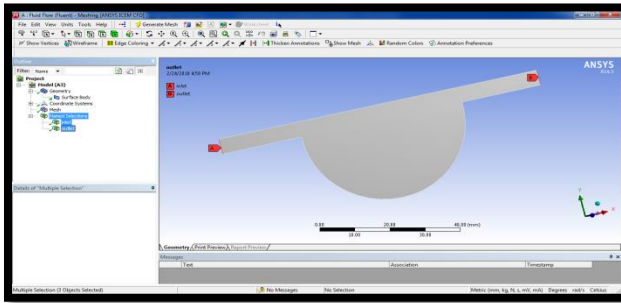

Boundary conditions are a required component of the mathematical model. Boundaries direct motion of flow. Specify fluxes into the computational domain, e.g. mass, momentum, and energy. Fluid and solid regions are represented by cell zones. Material and source terms are assigned to cell zones. Boundaries and internal surfaces are represented by face zones. Boundary data are assigned to face zones.

FLUID – METHANE + AIR

Pressure

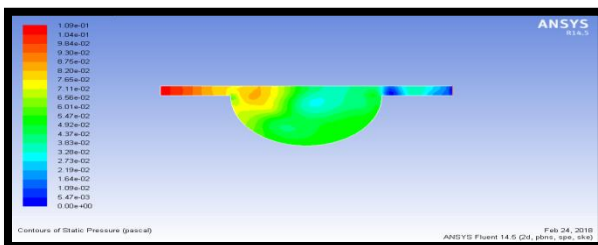

According to the pressure plot the maximum pressure value $1.09e-01$ Pa and minimum pressure value $5.47e-03$. The maximum pressure at inlet condition of combustion chamber and minimum pressure value at outlet conditions of the combustion chamber.

Velocity

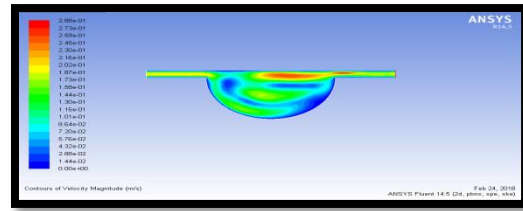

According to the velocity plot the maximum velocity value $2.88e-01$ Pa and minimum velocity value $1.44e-02$. The maximum velocity at upper middle portion of combustion chamber and minimum velocity value at lower right side of the combustion chamber.

Heat transfer coefficient

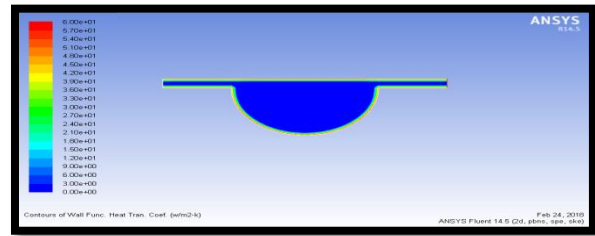

According to the Heat transfer coefficient plot the maximum velocity value $6.00e+01$ w/m²-k and minimum Heat transfer coefficient value $3.00e+00$ w/m²-k. The maximum Heat transfer coefficient at complete boundary of combustion chamber and minimum Heat transfer coefficient value at inside of the combustion chamber.

Mass fraction of O₂

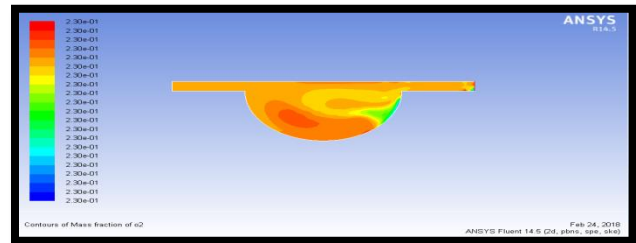

Mass fraction of N₂

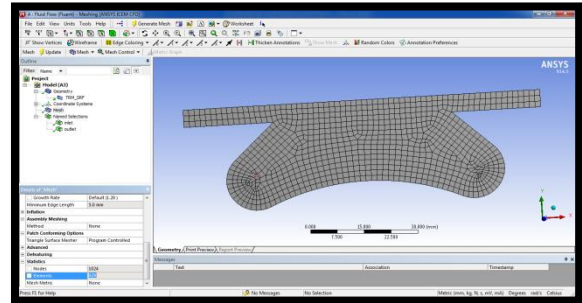
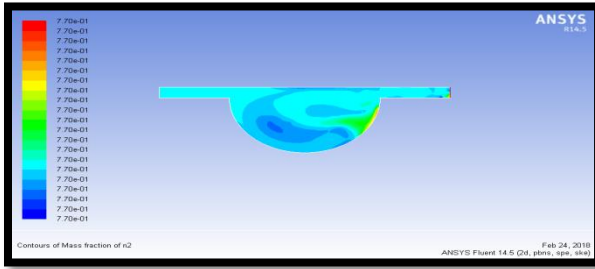

Variable	Original model	
	Methane(CH ₄) + air	Ethane(C ₂ H ₆) + air
Pressure(Pa)	109e-01	1.38e-01
Velocity (m/s)	2.88e-01	3.44e-01
Heat transfer coefficient (w/m ² -k)	6.00e+01	6.00e+01
mass	O ₂	2.30e-01
	N ₂	7.70e-01
	CH ₄ / C ₂ H ₆	5.71e-09
mole	O ₂	207e-08
	N ₂	7.93e-01
	CH ₄ / C ₂ H ₆	1.03e-08
Mass concentration	O ₂	8.43e-03
	N ₂	3.22e-02
	CH ₄ / C ₂ H ₆	4.17e-10

Inlet and outlet conditions

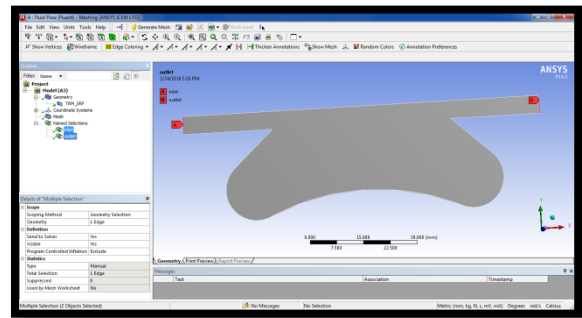

From the above result table when we notice that results like Pressure(Pa), Velocity (m/s), Heat transfer coefficient (w/m²-k), mass fraction (O₂, N₂ & CH₄/ C₂H₆) mole fraction (O₂, N₂ & CH₄/ C₂H₆) Mass concentration (O₂, N₂ & CH₄/ C₂H₆) for different fluids (methane & ethane) from the above data the mass concentration of combustion more for methane + air fluid.

FLUID – METHANE + AIR

MODIFIED MODEL OF COMBUSTION CHAMBER

Pressure

Imported model

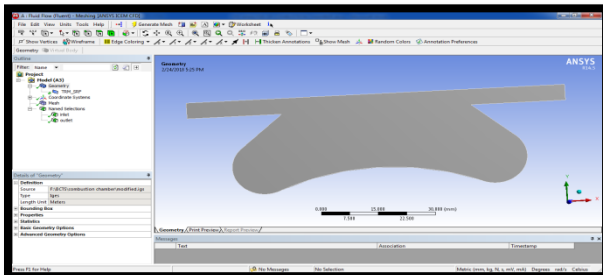
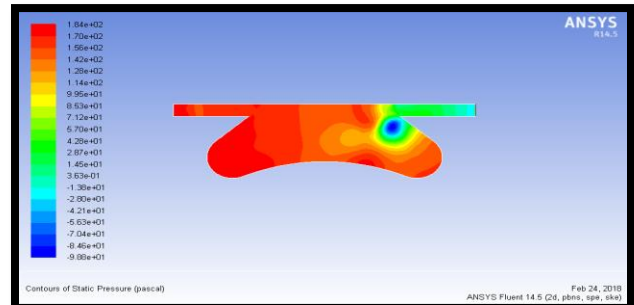

Velocity

Meshed model

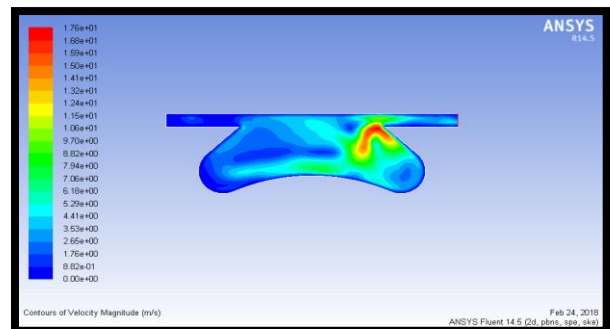

Heat transfer coefficient

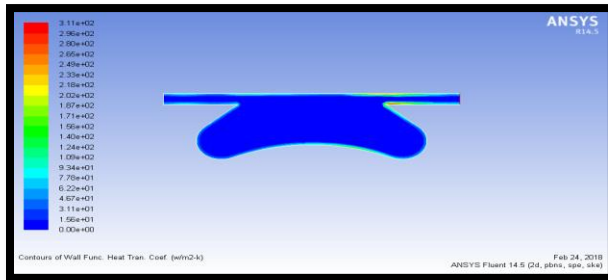

Variable	Modified model	
	Methane(CH ₄) + air	Ethane(C ₂ H ₆) + air
Pressure(Pa)	1.84e+02	9.62e-02
Velocity (m/s)	1.76e+01	2.58e-01
Heat transfer coefficient (w/m ² -k)	3.11e+02	6.37e+01
mass	O ₂	2.30e-01
	N ₂	9.98e-01
	CH ₄ / C ₂ H ₆	4.27e-08
mole	O ₂	2.08e-01
	N ₂	9.17e-01
	CH ₄ / C ₂ H ₆	3.16e-08
Mass concentration	O ₂	8.76e-03
	N ₂	3.80e-02
	CH ₄ / C ₂ H ₆	1.31e-09

From the above result table when we notice that results like Pressure(Pa), Velocity (m/s), Heat transfer coefficient (w/m²-k), mass fraction (O₂, N₂ & CH₄/ C₂H₆) mole fraction (O₂, N₂ & CH₄/ C₂H₆) Mass concentration (O₂, N₂ & CH₄/ C₂H₆) for different fluids (methane & ethane) from the above data the mass concentration of combustion more for methane + air fluid.

CONCLUSION

The following conclusions are drawn from the present work:

- The heat transfer coefficient value for original combustion chamber is more
- Mass fraction of N₂ is more than modified model.
- The mass fraction of O₂ is remain same.

By looking at the CFD evaluation of combustion chamber the authentic model have emission of methane and ethane for original and changed model. Compare with the combustion chamber models the mass concentration fee and warmth switch coefficient value is greater for changed version of combustion chamber. And while we compare the fluids of

combustion chamber the mass awareness of methane price is greater.

So it is able to be concluded the combustion chamber changed version and fluid methane+ air combination fluid is better overall performance.

REFERENCES

- [1] Combustion Chambers in CI Engines: A Review Arka Ghosh B. Tech. (Mechanical Engineering), SRM University, Kattankulathur, T.N., India – 603203
- [2] Design and Analysis of an Internal Combustion Engine Piston Head to Increase the Torque on Crankshaft Nagasundaram.S1, Nester Ruban.J2
- [3] Simulation And CFD Analysis of Various Combustion Chamber Geometry of A C.I Engine Using CFX Dr. Abdul Siddique1 , Shaik Abdul Azeez2 , Raffi Mohammed2
- [4] Full Cycle Cold Flow Analysis of the Effect of Twin Swirl Combustion Chamber Design in a Diesel Engine Doğan Güneş, Mehmet Serkan Horasan
- [5] A Review on the Different Geometries of Combustion Chamber in CI Engines on Performance, Ignition and Emission Alireza Lotfi1 , Hassan Ghassemi2,*
- [6] Design and Analysis of Gas Turbine Combustion Chamber P.Sravan Kumar1 , P.Punna Rao2
- [7] Analysis of Combustion Chambers in Internal Combustion Engine Ariz Ahmad*
- [8] Combustion traits of a swirl chamber kind diesel engine† Gyeung Ho Choi1 , Jae Cheon Lee2 , Tae Yun Kwon3 , Chang Uk Ha4 , Jong Soon Lee4 , Yon Jong Chung5 , Yong Hoon Chang6 and Sung Bin Han6,