



# Empowering people in India through Solar Power Tree Technology

Tarun Saxena<sup>1</sup>, Himanshu Yadav<sup>2</sup>, Rishika Chauhan, Sumit Singh, Dr. J.P. Kesari,

<sup>1</sup>234 B. Tech. Mechanical and Automotive Engineering, Delhi Technological University, Delhi, India

<sup>5</sup>Associate Professor Dept. of Mechanical Engineering, Delhi Technological University, Delhi, India

## Abstract

*Solar power tree deals with the improvement in design of Solar PV'S arrangement for electricity generation and effective utilization of land space. Due to limited land space, we are focussing on making our design that requires least space and more Solar PVs. This design is like a tree to give it a more artistic look. In this paper, we have designed and fabricated a 5.4kW PV system as solar tree. Apart from Design and fabrication, it also includes the cost analysis of the proposed Solar Power Tree, Tracking & Rotation mechanism and calculations related Weight/Load management, Tilt angle & Load Calculation. It also includes the energy demand of various income groups. This project encourages the usage of renewable energy – Solar resources.*

**Keywords:** Solar PV, Tree, Payback, Efficiency, Land optimization, Solar PV, Renewables, Renewable Energy, Economic Sections, Spiraling Phallotaxy Solar Energy, Designing Solar Tree

## Introduction

With the evolution of this world, the field of Science and Technology has also evolved, which changed the social patterns, population profile and lifestyle of people and hence increased the energy demand. Increment in population generated various issues like scarcity of electricity and many environmental issues. To deal with electricity problem a new player in the market of electricity generation is renewable energies and our main focus is on solar energy. Since the electricity generation due to Solar PVs requires a large area for set up and also flat or roof top mountings of PV systems require large area. Scarcity of land is greatest problem in cities and even in villages and India being a densely populated country, we came up with an alternative option. So there arise a need of effective utilization of space available and technological innovations in Solar PVs. This created the idea of Solar Power Tree (SPT). Solar Power Tree provides better alternative to flat mounting of PV systems.

A Solar Power Tree (SPT) is almost exactly what it sounds like, a tree structure with vertically oriented branches holding up photovoltaic panels leaves. Basically, a solar power tree is a decorative means of producing solar energy and electricity. It uses multiple no. of solar panels which forms the shape of a tree. The panels are arranged in a tree fashion in a tower or pole. Here TREE stands for

**T-** Tree Generating

**R-** Renewable

**E-** Energy and

**E-** Electricity

This is like a tree structure and the panels are like leaves of the tree which produces energy. One Solar Power Tree has an energy producing capacity of 5 kW's, using just four square feet of land compared to 400 square feet needed by a conventional solar array with the same output. That's enough energy to light five homes.

Solar Power Trees such as this one are capable of harnessing 10 to 15 percent more power compared to ground-mounted solar arrays. The tree charges a battery back-up system that can provide to hours of light after sunset on a full charge. The solar tree is also self-cleaning, with a built-in water sprinkler to clear any debris that would interfere with efficiency.

## The Salient Features of the Solar Power Tree are:

- It takes only 4 square feet of land for a 5 KW Solar Power tree, whereas in a conventional layout, it requires 400 square feet of land.
- By holding the photovoltaic panels at a higher height, on an average it gets more sunrays for one hour in a day. As a result, it is possible to harness 10-15% more power in comparison to a conventional layout on ground.
- It has a battery back-up of 2 hours on full load, hence giving light even after sunset.
- It is facilitated with water sprinkler at the top for self-cleaning of panels, that increases the efficiency of the solar panels.

- The estimated cost of the device is around Rs. 5 Lakh for a 5 KW specification.

## Literature review

Solar energy is available in abundance and considered as the easiest and cleanest means of tapping the renewable energy. For direct conversion of solar radiation into usable form, the routes are: solar thermal, solar photovoltaic and solar architecture. However, the main problem associated with tapping solar energy is the requirement to install large solar collectors that requires a very big space. To avoid this problem we can install a solar tree which requires a very small space.

Solar tree is a revolutionary urban lighting concept that represents a perfect symbiosis between pioneering design and cutting-edge eco-compatible technology. Solar Tree opens up new prospects for urban lighting in that it satisfies today's most pressing environmental, social, cultural and aesthetic demands. The ability to combine innovative design with advanced technology, along with an acute sensitivity to environmental concerns make **Artemide** the ideal vehicle for the development of this project conceived by **Ross Lovegrove** with the collaboration of Sharp Solar, the world's leading manufacturer of solar cells.



Figure 1: Energy Tree similar to natural Tree, Bristol Science Centre

The **Energy Tree in Millennium Square** at Bristol Science Centre was the first Solar Tree launched on 21<sup>st</sup> April 2015. The 20ft metal sculpture uses biomimicry to imitate a natural tree form with 36 leaves composed of solar PVs, fabricated by participants from **Bristol Drugs Project** during energy workshops delivered by Demand Energy Equality. The electrical

power produced is stored in batteries at its base and fed through the Tree's roots out of the soil through publicly accessible charging cables. It was all possible with the support of **Lush Charity Pot** award and a strategic grant from **Bristol 2015 European Green Capital**.

There were many aims of the Energy Tree: to build something functional and beautiful that engages the public in energy futures; to work with people combatting drug & alcohol use and demonstrate the power of building collectively; to celebrate the community energy movement; and to reach people with our message of the need to reduce our energy demand as a society. What's more, it provides free public phone charging and WIFI!

**Daniel C Staley** in his paper "Tree and Solar Power: Coexisting in an Urban Forest near you" describes several innovative policies to facilitate the successful coexistence of urban trees and rooftop solar energy collection. The benefits of strategically increasing tree canopy in built environments – increased energy savings from shade, increased solar power generation, reduced storm water peak flows, increased aesthetics, and improved environmental health – far outweigh the costs and pay dividends many times over.

**Deepak M Patil et al** analysed the cost of present Solar Power Tree and minimised for a single domestic household. He stated the overall cost of the domestic solar tree can be reduced by using the available local material. To reduce cost the design of tree structure should be simple and innovative. The performance (MPP) of solar tree better than conventional rooftop mountings as manual or low-cost auto tracking system can be easily incorporated. The initial investment cost is the major concern in PV system.



Figure 2: CMERI Solar Tree

In India, the development in Solar Tree started with Council of Scientific & Industrial Research (CSIR) - Central Mechanical Engineering Research Institute (CMERI), Durgapur, West Bengal under guidance of Chief Scientist **Dr. S N Maity**. Dr. Harsh Vardhan, launched the 'Solar Power Tree' last year in New Delhi.



Figure 3: India's Solar Tree Courtesy: CSIR-CMERI

The Solar Power Tree harnesses solar energy for producing electricity with an innovative vertical arrangement of solar cells. It thus reduces the requirement of land as compared to conventional Solar Photovoltaic layout, on one hand, while keeping the land character intact on the other. Even the cultivable land can be utilized for solar energy harnessing along with farming at the same time. The innovation finds its viability both in rural and urban areas.

The Solar Power Tree innovatively addresses the challenge of increasing demand for Green Energy by gainfully utilizing scarce land resources in the country. Further, the Minister noted that in order to produce 1 MW of solar power it requires about 3.5 acres of land in the conventional layout of solar panels. Thus, for any State in the country to survive on green energy, there will be requirement of thousands of acres of land. Acquisition of land is a major issue in itself, he added. As a future prospect, the Solar Power Tree would be developed in a rotatable module, which would have a motorized mechanism to align itself with the movement of the Sun during the day. Hence, it would be possible to harness 10-15% more power over and above the current capacity.

- The estimated cost of the device is around Rs. 5 Lakh for a 5 KW specification.

As a private player in the market, TITLIS Energy Pvt. Ltd. And various local vendors have shown a keen interest in developing Solar Power Tree for market.

## Need

### i. Due to less land requirement

It is the best option of energy generation because it requires very less land as compared to the traditional PV system. Now a days land became the costliest commodity for the human society because of high population growth. So we require such a plant which can generate maximum energy using minimum land.

### ii. Efficient energy generation

It can generate energy very efficiently as compared to traditional system. Due to the technique called spiralling phyllataxy its efficiency increases. Though it is somehow costly as compared to the all cost involved in traditional system it is more efficient.

### iii. It can collect energy from wind

As the name suggests this is a device to generate energy from sun but it has some unique feature to generate energy from wind. The stem are flexible so that they can rotate in any direction and by shaking themselves they produce energy from wind as in the case of a natural tree.

## Advantages and Disadvantages

### ADVANTAGES

- ✓ Can save society billions or trillions of dollars
- ✓ Space below tree can be used for Open Air Cafe similar Tea/Coffee café
- ✓ Space under the tree can be used as Outdoor Conferencing & Virtual training in rural areas for adults
- ✓ Can be installed in any place thus more beneficial
- ✓ Land requirement is very less & space below the tree can be used for Green House Cultivations in larger capacities
- ✓ Can be used for e-Learning using its Wi-Fi Networks & Digital Screens
- ✓ Users can generate substantial revenue due to Green Advertising possibilities
- ✓ Party plots can use this power thus promoting green culture
- ✓ Public places like Hospitals/Malls/Corporate Campuses/Train & Bus Stations can use this for public convenience & Digital Advertising Revenues
- ✓ All the parking space can be converted as Solar Parking Shed thus no need to waste money for parking sheds etc.

- ✓ Provides energy security
- ✓ Provides energy independence
- ✓ No air pollution
- ✓ People in poor & rural areas would have access to electricity

#### DISADVANTAGES

- × First time cost is high
- × May cause hazards to the birds & insects
- × People eyes will get affected by the solar reflectors.

### Design Methodology

In this project we have decided to design a solar PV tree with 18 panels of 300 watts each. The total system has a net power of 5.4 kW. In this system, we have basically 3 layers. These layers are at different heights depending from the ground. The complete height of the system from the ground is around 5-5.5m approx. The land area that it will be taking is around 4 sq. ft. which is just used to give root support to the tree. The dimension of solar panels is 1956 x 992 x 50mm. Pattern that we decided to work on is spiralling phyllotaxy. Wind pressure taken into account is according to the Delhi's weather and is 15 mph W. The load for which the analysis of the main pipe or trunk of solar tree was taken in account was around 500kg. A tracking system at each and every branch is placed for the rotation of the leaves.

Starting at the top there are three panels. Each is placed with automatic solar tracking system. They have appropriate space to move and turn. Coming to the next layer it is at 4.5m approx. height from the ground. This layer contain 5 panels all placed at different angles. All these panels are placed such that no one collide or coincide with any other panels at any position or angle. They are all in spiral geometry. Similarly the second layer which is at 3.5 m approx. height from the ground is placed with same geometry and with longer branch. Also in third layer the size of branch is increased and it is aligned in the same manner as first and second. It is at a height of 2.5m approx. from the ground. All the branches are connected to the pole through a wire that can withstand the load of panels and can also give support to the tree. The proposed design in created in solid works and sketches are presented here.

#### LEAF ARRANGEMENT- Spiralling Phyllotaxis

In botany, **phyllotaxis** or **phyllotaxy** is the arrangement of leaves on a plant stem. Phyllotactic spirals form a distinctive class of patterns in nature. The basic arrangements of leaves on a

stem are **opposite**, or **alternate** = **spiral**. Leaves may also be **whorled** if several leaves arise, or appear to arise, from the same level (at the same node) on a stem. This arrangement is fairly unusual on plants except for those with particularly short internodes. With an opposite leaf arrangement, two leaves arise from the stem at the same level (at the same node), on opposite sides of the stem. An opposite leaf pair can be thought of as a whorl of two leaves. A whorl can occur as a basal structure where all the leaves are attached at the base of the shoot and the internodes are small or non-existent. A basal whorl with a large number of leaves spread out in a circle is called a rosette.

With due adjustment of load over the pillar or pole, solar panels can be fixed throughout the tall pole following a pattern of **spiralling phyllotaxy** pattern as found in a natural tree.

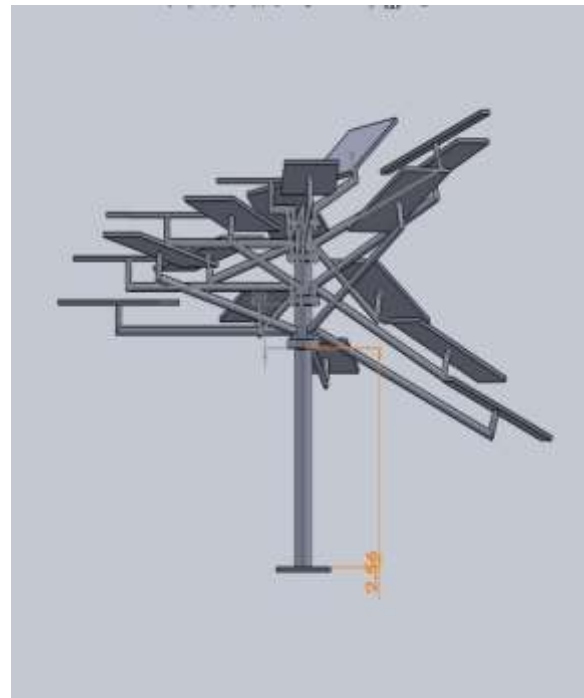

Figure 4: Side View of Proposed Solar Tree



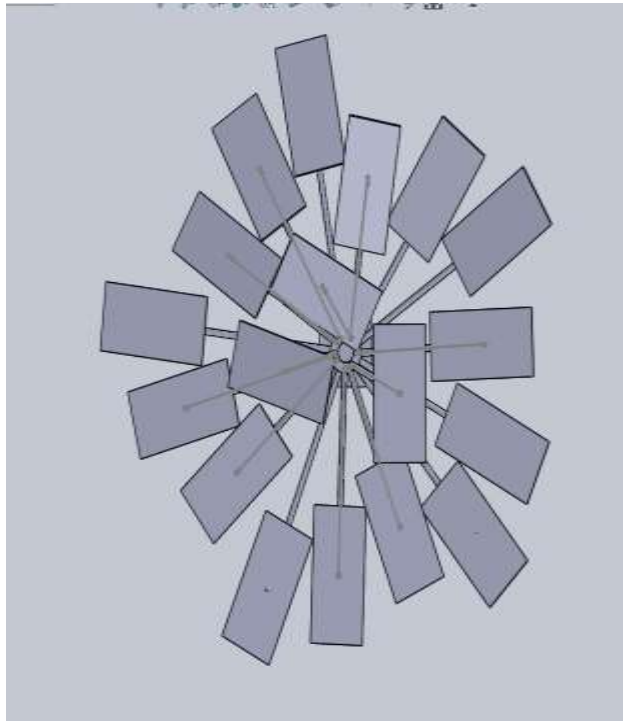
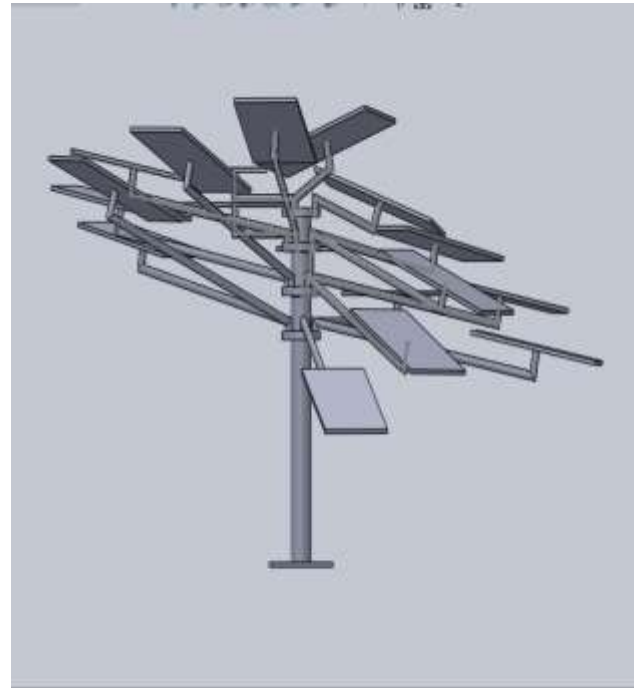

Figure 5: Top View

A **repeating spiral** can be represented by a fraction describing the angle of windings leaf per leaf. Alternate distichous leaves will have an angle of  $1/2$  of a full rotation. In beech and hazel the angle is  $1/3$ , in oak and apricot it is  $2/5$ , in sunflowers, poplar, and pear, it is  $3/8$ , and in willow and almond the angle is  $5/13$ . The numerator and denominator normally consist of a Fibonacci number and its second successor. The number of leaves is sometimes called rank, in the case of simple Fibonacci ratios, because the leaves line up in vertical rows. With larger Fibonacci pairs, the pattern becomes complex and non-repeating. This tends to occur with a basal configuration. This phyllotactic pattern creates an optical effect of criss-crossing spirals. In the botanical literature, these designs are described by the number of counter-clockwise spirals and the number of clockwise spirals. These also turn out to be Fibonacci numbers. In some cases, the numbers appear to be multiples of Fibonacci numbers because the spirals consist of whorls.

This repeating spiralling phyllotaxy arrangement similar to natural tree has been used for the design to get the maximum sun in a day time the top panel should not obstruct the bottom panels. The each panel will be hanging through their connecting stem system attached to the main trunk (Pole) and can rotate following the sun's path throughout a day.



It can also be locked at any position to withstand the wind pressure due to heavy storm affecting over the main pole/ trunk. The panels will be naturally facing towards the sun at an angle as required so that they can collect maximum solar energy in a daytime.

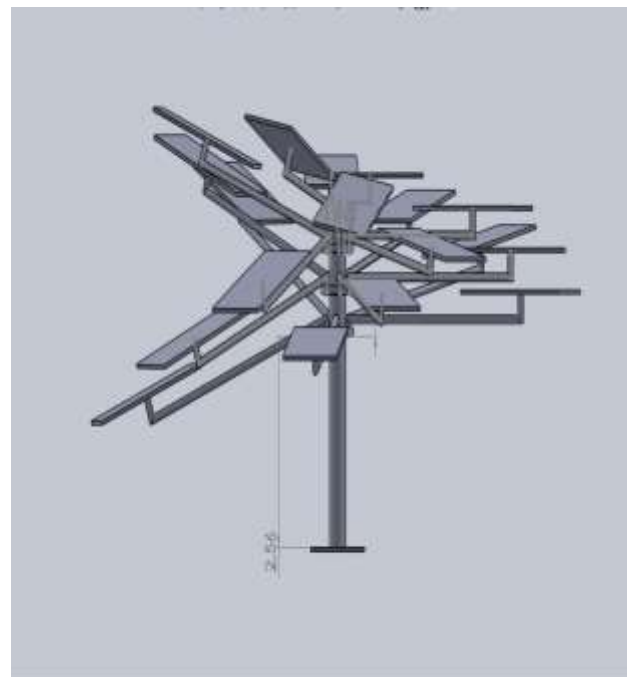

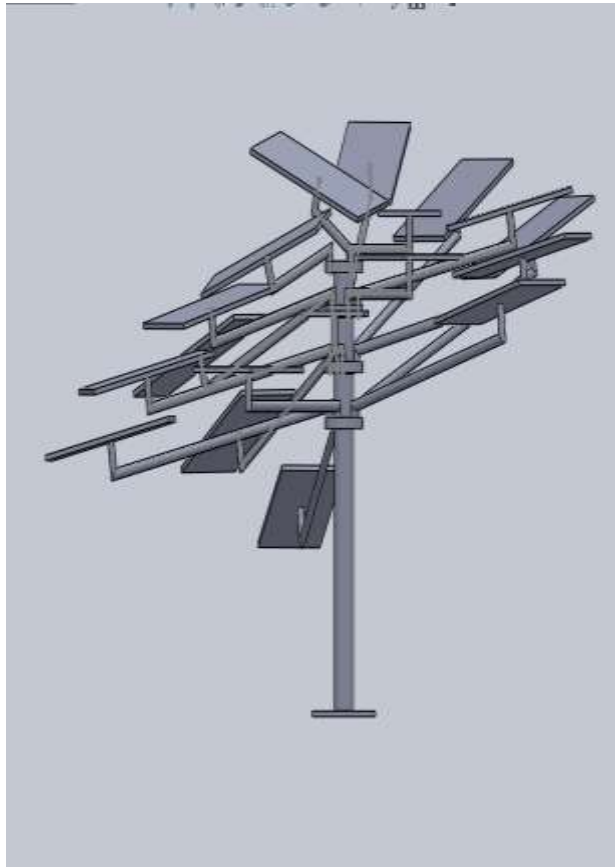

angled triangle with branch and trunk. After this the panel setup is attached to the branch so that panels can be easily placed on it. In the end all the panels are attached and placed properly. At the end all the other equipment and wires are joined.

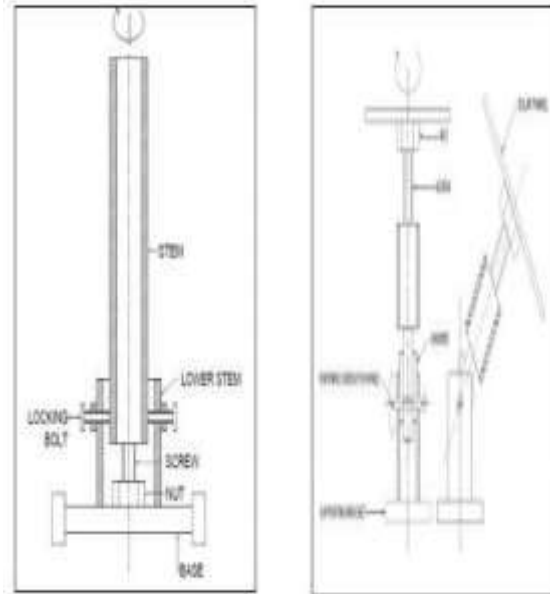

Figure 6: (a) Manual Tracking Arrangement of Solar Tree  
(b) Mounting of Solar Panel on bent arms at required inclination for maximum output

The system can be mounted at the roadsides, the islands in between wide roads / highways, on the boundary walls of paddy lands etc. The Tree structure can be easily constructed on the terrace or anywhere near the house of an individual. Maintenance and dust cleaning is also not a big issue. In order to accept the solar tree concept as the strong solution for urban and rural electrification, public perception about this technology is very essential. The People who will be using this technology, their idea, opinions can give better insight into applications of the solar tree for street lighting and other applications. By conducting surveys and exhibitions of different models of Solar Trees presented by many researchers can make a good platform for the progress of this technology.

## Fabrication

The fabrication of solar power tree is done at various steps. Firstly, the pipe required according to the desired strength, hardness and quality is selected and is placed in the ground. It is cemented in the ground. After that the branches of the truck starts to grow. For this we weld and screw the branch on the MS pipe. Each and every branch is placed in same manner and at apt position. After this, to give additional support to the branch a wire is being attached making a right

After the complete fabrication of the stand and the placement of panels and wire joining, the system is tested.

A prototype of proposed system is to be fabricated to test the feasibility of Solar Tree system. Solar PV Panels are mounted on a single tall pole (stem) with the help of suitable supporting base. The arrangement of solar panels maintains a 'Phyllotaxy' pattern. Two stems is fabricated from M.S. pipe of 3" diameter and about 6 feet in height. The stem is made in two parts to facilitate rotation of solar Tree for tracking the sun. The lower part is fixed and the upper part has the provision of rotation on which panels are mounted. At the bottom of lower stem (pipe) a nut is welded and at the lower part of upper stem, screw is welded, which can rotate in that nut. This arrangement is better than pivot bearing assembly because it rotates as per requirement. The bearing assembly rotates more freely which is not desirable and difficult to stop or control the rotations when there is high wind flow. The upper stem part locked by tightening the locking bolts. Structural support for panels cross base is used so that the structure is balanced and bear the load acting on it. To support the PV panels four arms of round bent up pipe are welded to upper part of the stem. Solar panels are mounted on angle brackets on

these arms of the tree. Angle joints is adjustable and are made up of stainless steel and can be adjusted with the help of Allen key. With this system, solar panels can be inclined to latitude or any other required angle (winter and summer correction) manually to get maximum sun radiations.

## Application

### 1. Solar Tree Product Applications

The Solar Tree is suitable for remote locations or where small foot print such as area lighting, car parks and street lighting are required. With a grid connection or battery store, the Solar Tree is the solution for energy requirements.

### 2. World's Best Looking Solar Gadget Charger



Figure 7: Solar Gadget Charger

The Concept of **Solar Tree is Photosynthesis**. To soak up juice from the sun, Bonsai tree uses 54 mini photovoltaic panels as leaves and able to charge the gadgets.

### 3. Making Light with Recycle Plastic Bottles



Figure 8: Light with Recycle Plastic Bottles

A normal PET-Bottle filled with water can be used as a light bulb to bring light into underprivileged households during the day.

### 4. Applications of Solar Trees for Industrial Power Supply, House Supply, Street Light



Fig.6. Industrial power House supply Street Light

Different applications of solar tree used for industrial power supply, house supply and for street light supply is shown in fig.

## Cost Estimation

The cost of Proposed Solar Power Tree is estimated using different tools & techniques such as Expert judgement, Analogous estimating, Three-point estimates (Best case, optimum case, worst case), spreadsheets and statistical tools.

**Expert Judgement:** Project mentor Dr. J P Kesari and expert from Zun Roof Solar, Vikram Solar have been consulted while preparing the cost estimation.

**Analogous Estimating:** Analogy has been used in the cost estimation from previous project and data.

**Three-point Estimates:** For 3-point estimates (Low, Medium & High Cost), separate estimates are made for cost and brand.

The proposed model requires Solar PVs modules, Batteries, Solar charge controller (MPPT type), Inverter (12KW 24VDC) & Fabrication by metal bars.

For better result we have considered various prices and brands.

Here we are using Kenbrook Solar panels of 300W 24V each. Battery bank used is of 8 batteries of specification 150Ah 12VDC, brand used is Exide Inva. 5kW Sukam off grid tie inverter (SRS-5k) is being used here. Mounting and other miscellaneous prices are also taken into account. Miscellaneous charges includes price of wires, labor and other spares.

Table 1 Cost Estimation Table

S.No.	Equipment	Quantity	Cost (INR)
1.	Panels	18	189000
2.	Battery	8	140000
3.	Invertor	1	63000
4.	Monitoring Kit	1	15000

5.	Mounting	-	58500
6.	Miscellaneous	-	20000

### Cost of Production

COP= Total Cost of the system/No. of units produced

Taking a time span of 20 years.

Total cost of the system= Rs.485500/-

Daily Production: 20 units

Yearly Production: 7300 units

### Total Cost: Rs.485500/-

Cost of Complete manufacturing of the system comes out to be **Rupees Four Lacs Eighty Five thousand and five hundred only.**

Cost Estimation on the basis of demand and income group is given in below table.

Table 2 Power Distribution according to Income Group

S. No.	Income Group	Energy (In Units)		System Required (KW)	Cost of system
		Consumption	Production		
1.	Weaker	1.872	2	0.5	50000
2.	Low	6.88	4	1	95000
			8	2	186000
3.	Middle	14.808	12	3	277000
			16	4	385000
4.	High	19.108	20	5	485500

### Output of System

1 kW system in Delhi produce 4 units of electricity daily.

1 kW – 4 units daily

5 kW – 20 units daily – 7300 units yearly

**Cost of 7300 units** according to TDDPL Rs.7.30 per unit (if monthly consumption is between 401-800 units) is **Rs.53290**. The amount here is calculated on the basis of Tata Delhi Distribution of Power Limited.

### Payback Period

Payback Period= Overall Cost of the system/ Average yearly electricity bill

Payback Period= 485500/53290= 9.11 years

This implies that system will be free after **9 years and 2 months** of use.

Table 3 Production cost according to different year

Year	Per Year	Total (For 5 Years)	Rated Capacity
1-5	20*365	36500	100%
6-10	.92*20*365	33580	92%
11-15	.85*20*365	31025	85%
16-20	.75*20*365	27375	75%
	<b>Total</b>	<b>128480</b>	

Now Cost of production if we consider a time span of 20 years

COP= 485500/128480= Rs.3.77

Table 4 Cost of Production

Time Span	COP per unit (INR)
5 Years	13.31
10 Years	6.93
15 Years	4.80
20 Years	3.77

By this we can say that cost of production of electricity using solar tree of 5.4kw will be **Rs.3.77 per unit for a time span of 20 years.**

### Calculation (For Power)

In this work, we have presented our thought that Solar Tree concept for domestic electrification is big step to reduce electricity bills and dependence on grid power which is unreliable nowadays in India. It also provides clean energy source to reduce the global



warming. Energy demand (load) of the small family is considered and taken for determining the capacity of proposed system and system component sizes.

#### LOAD ESTIMATION:

The average load profiles are considered depending on daily usage duration in a day. Following electrical appliances are for total load estimation. Hence, Total load or power requirement is approx. equal to 80 units per month or 2.5 units per day.





Appliances	Watt	No. Of Equipments	Hour Use/Day	Days Use/Month	Total Load	Total Consumy in KWH ( )
 CFL Lamp	8	2	8	30	16	3.84
 Fan	60	2	5	30	120	18.00
 Small Television	110	1	4	30	110	13.20
 Refrigerator 165 litres	180	1	8	30	180	43.20
<b>Total Consumption</b>					<b>426</b>	<b>78.24</b>

Figure 7: Daily Energy Demand for small house; Courtesy: UPPCL

The average load profiles are considered depending on daily usage duration in a day. Following electrical appliances are for total load estimation. Here we have calculated the load demand for various income groups. These income groups are divided in four categories: Weaker section, low income, middle income, High income.

Table 5 Energy Demand for Weaker Section

Appliances	Rated Power (W)	Qty.	Hr./ day (Each)	KWh/ day
<b>CFL Bulb</b>	12	4	10	0.432
<b>T.V</b>	40	1	4	0.16
<b>Fans</b>	60	2	16	1.28
<b>Total</b>				<b>1.872</b>

Energy Demand for **weaker section is 1.872 units per day.**

Table 6 Energy Demand for Low Income Group

Appliances	Rated Power (W)	Qty.	Hr./ day (Each)	KWh/ day
<b>CFL Bulb</b>	12	4	4	0.64
<b>T.V</b>	40	1	4	0.16
<b>Cooler</b>	300	1	4	1.2
<b>Refrigerator</b>	100	1	20	2.0
<b>Fans</b>	60	3	8	2.88
<b>Total</b>				<b>6.88</b>

Energy Demand for **low income section is 6.88 units per day.**

Table 7 Energy Demand for Middle Income Group

Appliances	Rate d Power (W)	Qty.	Hr./ day (Each)	KWh/ day
<b>CFL Bulb</b>	12	8	4	1.28
<b>T.V</b>	40	1	4	0.16
<b>Cooler</b>	300	2	4	2.4
<b>Refrigerator</b>	100	1	20	2.0
<b>Fans</b>	60	4	4	1.92
<b>A.C.</b>	1.5 Ton	1	5	3.35
<b>Water Pump</b>	1000	1	2	1.5
<b>Washing Machine</b>	1350	1	2	1.418
<b>Dishwasher</b>	1500	1	5	.78
<b>Total</b>				<b>14.808</b>

Energy Demand for **middle income section is 14.808 units per day.**

Table 8 Energy Demand for High Income Group

Appliances	Rate d Power (W)	Qty.	Hr./day (Each)	KWh/day
<b>CFL Bulb</b>	12	8	4	1.28
<b>T.V</b>	40	1	4	0.16
<b>Refrigerator</b>	100	1	20	2.0
<b>Fans</b>	60	4	4	1.92
<b>A.C.</b>	1.5 Ton	3	5	10.05
<b>Water Pump</b>	1000	1	2	1.5
<b>Washing Machine</b>	1350	1	2	1.418
<b>Dishwasher</b>	1500	1	5	.78
<b>Total</b>				<b>19.108</b>

Energy Demand for **high income section is 19.108 units per day.**

By this we can conclude that our solar tree can easily give power to many houses in a single day.

### Result

Solar tree of 18 panels producing a power of 5.4kw is used. Cost of complete system comes to be out of Rs.485500 (Rupees Four lacs Eighty Five thousand Five hundred only).

If the payback period is calculated according to the electricity consumption of 1 year at a rate of Rs.7.30 per unit, it comes to be 9 years and 2 months.

For a time span of 20 years the cost of production that comes out is Rs.3.77, which is similar bus lesser to the thermal production which is around Rs.4 per unit.

By doing research on various kind of income group and there energy needs on the daily basis different kind of system can be manufactured and can be fitted in their household. All the necessary household items and there quantities are used here for calculations and after that result is calculated.

Electricity consumption for weaker section is 1.872 units per day, for lower income groups is 6.88 units per day, for middle income groups is 14.808 units per day and for high income group is 19.108 units per day.

By using these systems we can easily power many houses in a locality and in a very limited space. Best reason of using solar tree is its eco-friendly nature.

### Conclusion

The solar tree concept is very successful to fulfil the increasing energy demand of the people, saving of land, and should be implemented in India to provide electricity without the problem of power cut-off and reduce the dependence on grid power. Daily average energy requirement of the small Indian family is calculated about 1.75kWh. Such systems can be mounted on the terrace, in front of the house or near the wall avoiding shading areas

The overall cost of the domestic solar tree can be reduced by using the available local material. To reduce cost the design of tree structure should be simple and innovative. The performance (MPP) of solar tree better than conventional rooftop mountings as manual or low-cost auto tracking system can be easily incorporated. The initial investment cost is the major concern in PV system. The payback period of proposed system seems to be high but due to continuous increase in the cost of grid power and reduction in the cost of PV cell due to technological advancement long payback period can be compensated.

The same design procedure can be extended to other locations and applications involving higher energy consumptions. Government aid and financial support for PV system equipment installation are highly recommended. Collaborative research work amongst Chemists, Physicists and Engineers will resolve the problem. At the last Solar Tree shall not harm ecology and should work harmony with natural trees.

### Way Forward

In future, we can applications of Solar Power Tree in Expressways

- Hospital
- School & Colleges
- Super Mall
- Digital Hoardings

### FUTURE APPLICATIONS OF SOLAR POWER TREE



Figure 8: Expressway



Figure 11: Digital Hoarding



Figure 9: Hospitals



Figure 10: Schools/ Colleges/ Super Malls

### References

- [1]. Subrata Kr Mandal, Antanu Maity, S Nimiety, (2015, 3), "Solar Tree- An Innovative Approach for Rural Energy Source", Applied Science Reports.
- [2]. C.Bhuvanewari, R. Rajeswari & others, (2013, 12), "Idea to Design a Solar Tree Using Nanowire Solar Cells"- International Journal of Scientific and Research Publications, Volume3, Issue 12.
- [3]. Sushma Gupta, Monish Gupta, (2015, 3), "The Benefits and Applications of Solar Tree with Natural Beauty of Trees", Applied Science Report, PSCI Publications, 117-124.
- [4]. Patil M Deepak et al (2016, 7), "Design and Development of Solar Tree ", International Journal of Engineering Sciences & Research Technology, Volume 8, Issue-3
- [5]. S.N. Maity, (2013, 2) "Development of Solar Power Tree – An Innovation that Uses Up Very Less Land and Yet enerates much more Energy from the Sun Rays by SPV Method", Journal of Environment and Nano Technology, Volume 2, 59-69 pp.
- [6]. Elisavet Dimitrokalia, Jamie Mackrilla, Graham Jonesb, Yorck Ramachersb, Rebecca Caina, "Moving away from flat solar panels to PV Trees: Exploring ideas and people's perceptions", International Conference on Sustainable Design, Engineering and Construction, Procedia Engineering 118 (2015) 1208 – 1216.
- [7]. Case study- Energy Tree, Bristol Science Centre
- [8]. Case Study-CSIR-CMERI Solar Power Tree