

# Design and implementation of High performance Montgomery Modular Multiplication on Verilog HDL

1Sukanya Anumala Setty, 2Sai Sravanthi Gandham, 3 Rahamtula shaik

<sup>1</sup>PG Scholar, Dept of ECE QIS Institute of Technology, Ongole, AP, India.

<sup>2</sup>Associate Professor, QIS Institute of Technology, Ongole, AP, India.

<sup>3</sup>Associate Professor, QIS Institute of Technology, Ongole, AP, India.

## Abstract

*The Montgomery multiplication algorithm such that the low-cost and high-performance Montgomery modular multiplier can be implemented accordingly. The proposed multiplier receives and outputs the data with binary representation and uses only one-level carry-save adder (CSA) to avoid the carry propagation at each addition operation. This CSA is also used to perform operand precomputation and format conversion from the carry save format to the binary representation, leading to a low hardware cost and short critical path delay at the expense of extra clock cycles for completing one modular multiplication. To overcome the weakness, a configurable CSA (CCSA), which could be one full-adder or two serial half-adders, is proposed to reduce the extra clock cycles for operand precomputation and format conversion by half. In addition, a mechanism that can detect and skip the unnecessary carry-save addition operations in the one-level CCSA architecture while*

*maintaining the short critical path delay is developed.*

Index Terms— carry-save addition, low-cost architecture, Montgomery modular multiplier, public-key cryptosystem.

## I. Introduction

In many public-key cryptosystems, modular multiplication (MM) with large integers is the most critical and time-consuming operation. Therefore, numerous algorithms and hardware implementation have been presented to carry out the MM more quickly, and Montgomery's algorithm is one of the most well-known MM algorithms. Montgomery's algorithm [4] determines the quotient only depending on the least significant digit of operands and replaces the complicated division in conventional MM with a series of shifting modular additions to produce  $S = A \times B \times R^{-1} \pmod{N}$ , where  $N$  is the  $k$ -bit modulus,  $R^{-1}$  is the inverse of  $R$  modulo  $N$ , and  $R = 2^k \pmod{N}$ . As a result, it can be easily

implemented into VLSI circuits to speed up the encryption / decryption process. However, the three-operand addition in the iteration loop of Montgomery's algorithm as shown in step 4 of Fig. 1 requires long carry propagation for large operands in binary representation. To solve this problem, several approaches

---

*Algorithm MM:*  
Radix-2 Montgomery modular multiplication

---

*Inputs :*  $A, B, N$  (modulus)  
*Output :*  $S[k]$

1.  $S[0] = 0;$
2. for  $i = 0$  to  $k - 1$  {
3.  $q_i = (S[i]_0 + A_i \times B_0) \bmod 2;$
4.  $S[i+1] = (S[i] + A_i \times B + q_i \times N) / 2;$
5. }
6. if ( $S[k] \geq N$ )  $S[k] = S[k] - N;$
7. return  $S[k];$

Fig. 1. MM algorithm.

based on carry-save addition were proposed to achieve a significant speedup of Montgomery MM. Based on the representation of input and output operands, these approaches can be roughly divided into semi-carry-save (SCS) strategy and full carry-save (FCS) strategy. In the SCS strategy, the input and output operands (i.e.,  $A, B, N,$  and  $S$ ) of the Montgomery MM are represented in binary, but intermediate results of shifting modular additions are kept in the carry-save format to avoid the carry propagation. However, the format

conversion from the carry-save format of the final modular product into its binary representation is needed at the end of each MM.

This conversion can be accomplished by an extra carry propagation adder (CPA) or reusing the carry-save adder (CSA) architecture [8] iteratively. Contrary to the SCS strategy, the FCS strategy maintains the input and output operands  $A, B,$  and  $S$  in the carry-save format, denoted as  $(AS, AC), (BS, BC),$  and  $(SS, SC),$  respectively, to avoid the format conversion, leading to fewer clock cycles for completing a MM. Nevertheless, this strategy implies that the number of operands will increase and that more CSAs and registers for dealing with these operands are required. Therefore, the FCS-based Montgomery modular multipliers possibly have higher hardware complexity and longer critical path than the SCS-based multipliers. Kuang et al. [10] have proposed an energy-efficient FCS-based multiplier (denoted as FCS-MMM42 multiplier) in which the superfluous operations of the four-to-two (two-level) CSA architecture are suppressed to reduce the energy dissipation and enhance the throughput. However, the FCS-MMM42

multiplier still suffers from the high area complexity and long critical path delay. Other techniques, such as parallelization, high-radix algorithm, and systolic array design, can be combined with the CSA architecture to further enhance the performance of Montgomery multipliers. However, these techniques probably cause a large increase in hardware complexity and power/energy dissipation, which is undesirable for portable systems with constrained resources. Accordingly, this paper aims at enhancing the performance of CSA-based Montgomery multiplier while maintaining low hardware complexity. Instead of the FCS-based multiplier with two-level CSA architecture in, a new SCS-based Montgomery MM algorithm and its corresponding hardware architecture with only one-level CSA are proposed in this paper. The proposed algorithm and hardware architecture have the following several advantages and novel contributions over previous designs. First, the one-level CSA is utilized to perform not only the addition operations in the iteration loop of Montgomery's algorithm but also  $B + N$  and the format conversion, leading to a very short critical path and lower hardware cost. However, a lot of extra clock cycles are

required to carry out  $B + N$  and the format conversion via the one-level CSA architecture. Therefore, the benefit of short critical path will be lessened. To overcome the weakness, we then modify the one-level CSA architecture to be able to perform one three-input carry-save addition or two serial two-input carry-save additions, so that the extra clock cycles for  $B + N$  and the format conversion can be reduced by half. Finally, the condition and detection circuit, which are different with that of FCS-MMM42 multiplier, are developed to precompute quotients and skip the unnecessary carry-save addition operations in the one-level configurable CSA (CCSA) architecture while keeping a short critical path delay. Therefore, the required clock cycles for completing one MM operation can be significantly reduced.

## II. Montgomery Multiplication

In this section, we propose a new SCS-based Montgomery MM algorithm to reduce the critical path delay of Montgomery multiplier. In addition, the drawback of more clock cycles for completing one multiplication is also improved while maintaining the advantages of short critical path delay and low hardware

complexity. A. Critical Path Delay Reduction The critical path delay of SCS-based multiplier can be reduced by combining the advantages of FCS-MM-2 and SCS-MM-2. Fig. 7 shows the modified SCS-based Montgomery multiplication (MSCS-MM) algorithm and one possible hardware architecture, respectively. The Zero\_D circuit in Fig. 7 is used to detect whether SC is equal to zero, which can be accomplished using one NOR operation. The Q\_L circuit decides the  $q_i$  value according to step 7 of Fig. 2. The carry propagation addition operations of  $B + N$  and the format conversion are performed by the one-level CSA architecture of the MSCS-MM multiplier through repeatedly executing the carry-save addition  $(SS, SC) = SS + SC + 0$  until  $SC = 0$ . In addition, we also precompute  $A_i$  and  $q_i$  in iteration  $i-1$  (this will be explained more clearly in Section III-C) so that they can be used to immediately select the desired input operand from 0, N, B, and D through the multiplexer M3 in iteration  $i$ . Therefore, the critical path delay of the MSCS-MM multiplier can be reduced into  $TMUX4 + TFA$ .

```

Algorithm Modified SCS-MM:
Modified SCS-based Montgomery multiplication
Inputs : A, B, N (modulus)
Output : SS[k+2]
1. (SS, SC) = (B + N + 0);
2. while (SC != 0)
3.   (SS, SC) = (SS + SC + 0);
4.   D = SS;
5.   SS[0] = 0; SC[0] = 0;
6.   for i = 0 to k + 1 {
7.      $q_i = (SS[i]_0 + SC[i]_0 + A_i \times B_0) \text{ mod } 2$ ;
8.     if ( $A_i = 0$  and  $q_i = 0$ )  $x = 0$ ;
9.     if ( $A_i = 0$  and  $q_i = 1$ )  $x = N$ ;
10.    if ( $A_i = 1$  and  $q_i = 0$ )  $x = B$ ;
11.    if ( $A_i = 1$  and  $q_i = 1$ )  $x = D$ ;
12.     $(SS[i+1], SC[i+1]) = (SS[i] + SC[i] + x) / 2$ ;
13.  }
14. while (SC[k+2] != 0)
15.    $(SS[k+2], SC[k+2]) = (SS[k+2] + SC[k+2] + 0)$ ;
16. return SS[k+2];

```

Fig.2.Modified SCS-based Montgomery multiplication algorithm

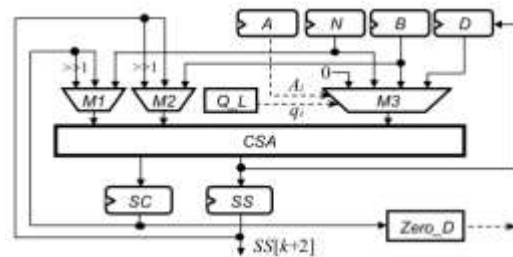

Fig. 3. MSCS-MM multiplier.

three-input carry-save additions [i.e., step 12 of Fig. 2(a)]  $k + 2$  times, many extra clock cycles are required to perform  $B + N$  and the format conversion via the one-level CSA architecture because they must be performed once in every MM. Furthermore, the extra clock cycles for performing  $B+N$  and the format conversion through repeatedly executing the carry-save addition  $(SS, SC) = SS + SC + 0$  are dependent on the longest carry propagation chain in  $SS + SC$ . If  $SS = 111...1112$  and  $SC = 000...0012$ , the one-

level CSA architecture needs  $k$  clock cycles to complete  $SS + SC$ .

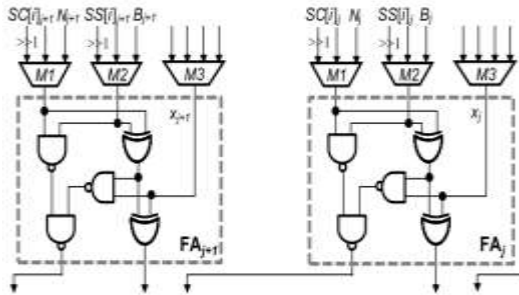

Fig.4. Conventional FA circuit

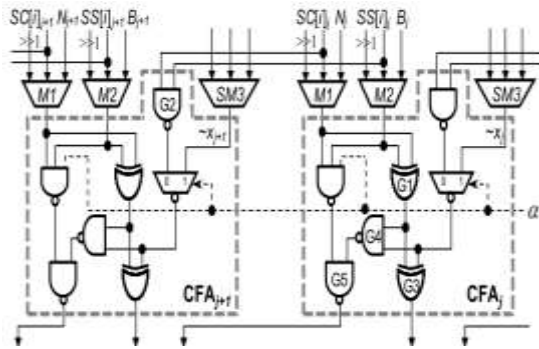

Fig.5. Existing CFA circuit.

That is,  $3k$  clock cycles in the worst case are required for completing one MM. Thus, it is critical to reduce the required clock cycles of the MSCS-MM multiplier.

B. Clock Cycle Number Reduction To decrease the clock cycle number, a CCSA architecture which can perform one three-input carry-save addition or two serial two-input carry-save additions is proposed to substitute for the one-level CSA architecture in Fig. 2. Fig. 5 shows two cells of the one-

level CSA architecture in Fig. 3., each cell is one conventional FA which can perform the three-input carry-save addition. Fig. 5 shows two cells of the proposed configurable FA (CFA) circuit. If  $\alpha = 1$ , CFA is one FA and can perform one three-input carry-save addition (denoted as 1F\_CSA). Otherwise, it is two half-adders (HAs) and can perform two serial two-input carry-save additions (denoted as 2H\_CSA), as shown. In this case, G1 of CFA<sub>j</sub> and G2 of CFA<sub>j+1</sub> in Fig. 5 will act as HA1<sub>j</sub>, and G3, G4, and G5 of CFA<sub>j</sub> in Fig. 5 will behave as HA2<sub>j</sub>. Moreover, we modify the 4-to-1 multiplexer M3 in Fig. into a simplified multiplier SM3 because one of its inputs is zero, where  $\sim$  denotes the INVERT operation. Note that M3 has been replaced by SM3 in the proposed one-level CCSA architecture. According to the delay ratio shown

In addition, we also skip the unnecessary operations in the for loop (steps 6 to 13) of Fig. 2 to further decrease the clock cycles for completing one Montgomery MM. The crucial computation in the for loop of Fig. 7(a) is performing the following three-to-two carry-save addition:  $(SS[i + 1], SC[i + 1]) = (SS[i] + SC[i] + x)/2$  (1) where the variable  $x$  may be 0, N, B, or

D depending on the values of  $A_i$  and  $q_i$ . The computation process of (1) is shown in Fig. 9. When  $A_i = 0$  and  $q_i = 0$ ,  $x$  is equal to 0 and  $SS[i]_0$  must be equal to  $SC[i]_0$  because the sum of  $SS[i]_0 + SC[i]_0 + x_0$  is equal to 0. That is, if  $A_i = 0$  and  $q_i = 0$ , then  $SS[i]_0 = SC[i]_0$ . Based on this observation, we can conclude that the sum of the carry propagation addition  $SS[i+1]_{k+1:0} + SC[i+1]_{k+1:0}$  is equal to the sum of the carry propagation addition  $SS[i]_{k+1:1} + SC[i]_{k+1:1}$  when  $A_i = q_i = 0$  and  $SS[i]_0 = SC[i]_0 = 0$ . As a result, the computation of (1) in iteration  $i$  can be skipped if we directly right shift the outputs of one-level CSA architecture in the  $(i-1)$ th iteration by two bit positions (i.e., divided by 4) instead of one bit position (i.e., divided by 2) when  $A_i = q_i = 0$  and  $SS[i]_0 = SC[i]_0 = 0$ . Accordingly, the signal  $skip_{i+1}$  used in the  $i$ th iteration to indicate whether the carry-save addition in the  $(i+1)$ th iteration will be skipped can be expressed as  $skip_{i+1} = \sim(A_{i+1} \vee q_{i+1} \vee SS[i+1]_0)$  (2) where  $\vee$  represents the OR operation.

### III. Proposed Algorithm and Hardware Architecture

On the bases of critical path delay reduction, clock cycle number reduction, and quotient precomputation mentioned above, a new SCS-based Montgomery MM algorithm (i.e., SCS-MM-New algorithm shown in Fig.6) using one-level CCSA architecture is proposed to significantly reduce the required clock cycles for completing one MM. As shown in SCS-MM-New algorithm, steps 1–5 for producing  $\hat{B}$  and  $\hat{D}$  are first performed. Note that because  $q_{i+1}$  and  $q_{i+2}$  must be generated in the  $i$ th iteration, the iterative index  $i$  of Montgomery MM will start from  $-1$  instead of 0 and the corresponding initial values of  $\hat{q}$  and  $\hat{A}$  must be set to 0. Furthermore, the original for loop is replaced with the while loop in SCS-MM-New algorithm to skip some unnecessary iterations when  $skip_{i+1} = 1$ . In addition, the ending number of iterations in SCS-MM-New algorithm is changed to  $k+4$  instead of  $k+1$ . This is because  $B$  is replaced with  $\hat{B}$  and thus three extra iterations for computing division by two are necessary to ensure the correctness of Montgomery MM. In the while loop, steps 8–12 will be performed in the proposed one-level CCSA architecture with one 4-to-1 multiplexer. The computations of  $q_{i+1}$ ,  $q_{i+2}$ , and  $skip_{i+1}$

in step 13 and the selections of  $\hat{A}$ ,  $\hat{q}$ , and  $i$  in steps 14–20 can be carried out in parallel with steps 8–12. Note that the right-shift operations of steps 12 and 15 will be delayed to next clock cycle to reduce the critical path delay of corresponding hardware architecture.

```

Algorithm SCS-MM-New:
Proposed SCS-based Montgomery multiplication
Inputs : A, B, N̂ (new modulus)
Output : SS[k+5]
1. B = B << 3; q̂ = 0; Â = 0; skip_{i-1} = 0;
2. (SS, SC) = 1F_CSA(B, N̂, 0);
3. while (SC != 0)
4.   (SS, SC) = 2H_CSA(SS, SC);
5. D̂ = SS;
6. i = -1; SS[-1] = 0; SC[-1] = 0;
7. while (i ≤ k + 4) {
8.   if (Â = 0 and q̂ = 0) x = 0;
9.   if (Â = 0 and q̂ = 1) x = N̂;
10.  if (Â = 1 and q̂ = 0) x = B;
11.  if (Â = 1 and q̂ = 1) x = D̂;
12.  (SS[i+1], SC[i+1]) = 1F_CSA(SS[i], SC[i], x) >> 1;
13.  compute q_{i+1}, q_{i+2}, and skip_{i+1} by (5), (7) and (8);
14.  if (skip_{i+1} = 1) {
15.    SS[i+2] = SS[i+1] >> 1; SC[i+2] = SC[i+1] >> 1;
16.    q̂ = q_{i+2}; Â = A_{i+2}; i = i + 2;
17.  }
18.  else {
19.    q̂ = q_{i+1}; Â = A_{i+1}; i = i + 1;
20.  }
21. }
22. q̂ = 0; Â = 0;
23. while (SC[k+5] != 0)
24.   (SS[k+5], SC[k+5]) = 2H_CSA(SS[k+5], SC[k+5]);
25. return SS[k+5];

```

Fig. 6. SCS-MM-New algorithm.

multiplier SM3, one skip detector Skip\_D, one zero detector Zero\_D, and six registers. Skip\_D is developed to generate  $skip_{i+1}$ ,  $\hat{q}$ , and  $\hat{A}$  in the  $i$ th iteration. Both M4 and M5 in Fig. 11 are 3-bit 2-to-1 multiplexers and they are much smaller than  $k$ -bit

multipliers M1, M2, and SM3.

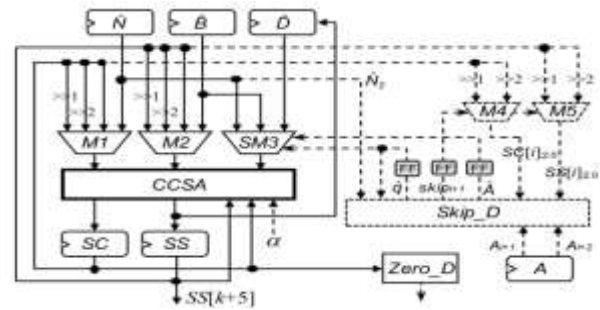

Fig. 7. SCS-MM-New multiplier.

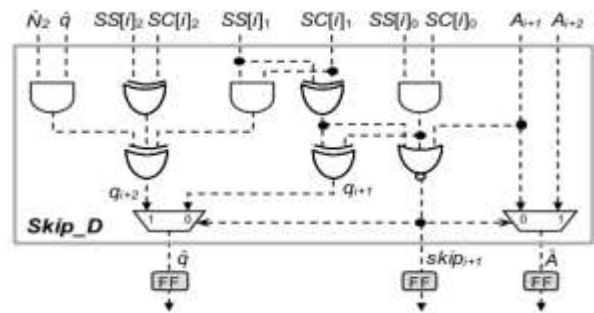

Fig. 8. Skip detector Skip\_D

In addition, the area of Skip\_D is negligible when compared with that of the  $k$ -bit one-level CCSA architecture. Similar to Fig. 4, the select signals of multiplexers M1 and M2 in Fig. 11 are generated by the control part, which are not depicted for the sake of simplicity. Fig. 12. Skip detector Skip\_D. At the beginning of Montgomery multiplication, the FFs stored  $skip_{i+1}$ ,  $\hat{q}$ ,  $\hat{A}$  are first reset to 0 as shown in step 1 of SCS-MM-New algorithm so that  $\hat{D} = \hat{B} + \hat{N}$  can be computed via the one-level CCSA architecture. When performing the

while loop, the skip detector Skip\_D shown in Fig. 12 is used to produce  $skip_{i+1}$ ,  $q^{\wedge}$ , and  $A^{\wedge}$ . The Skip\_D is composed of four XOR gates, three AND gates, one NOR gate, and two 2-to-1 multiplexers. It first generates the  $q_{i+1}$ ,  $q_{i+2}$ , and  $skip_{i+1}$  signal in the  $i$ th iteration according to (5), (7), and (8), respectively, and then selects the correct  $q^{\wedge}$  and  $A^{\wedge}$  according to  $skip_{i+1}$ . At the end of the  $i$ th iteration,  $q^{\wedge}$ ,  $A^{\wedge}$ , and  $skip_{i+1}$  must be stored to FFs.

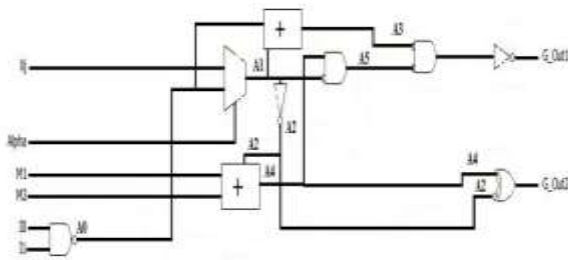

Fig.9. Proposed CCSA architecture.

In the next clock cycle of the  $i$ th iteration, SM3 outputs a proper  $x$  according to  $q^{\wedge}$  and  $A^{\wedge}$  generated in the  $i$ th iteration as shown in steps 8–11, and M1 and M2 output the correct SC and SS according to  $skip_{i+1}$  generated in the  $i$ th iteration. That is, the right-shift 1-bit operations in steps 12 and 15 of SCS-MM-New algorithm are performed together in the next clock cycle of iteration  $i$ . In addition, M4 and M5 also

select and output the correct  $SC[i]_{2:0}$  and  $SS[i]_{2:0}$  according to  $skip_{i+1}$  generated in the  $i$ th iteration. Note that  $SC[i]_{2:0}$  and  $SS[i]_{2:0}$  can also be obtained from M1 and M2 but a longer delay is required because they are 4-to-1 multiplexers. After the while loop in steps 7–21 is completed,  $q^{\wedge}$  and  $A^{\wedge}$  stored in FFs are reset to 0. Then, the format conversion in steps 23 and 24 can be performed by the SCS-MM-New multiplier similar to the computation of  $D^{\wedge} = B^{\wedge} + N^{\wedge}$  in steps 3 and 4. Finally,  $SS[k + 5]$  in binary format is outputted when  $SC[k + 5]$  is equal to 0.

	Existing	Proposed
Delay	1158.613ns	1150550ns

Fig. 10. Results

#### IV. Simulation and Synthesize Results



Fig. 11. Simulation Wave Forms

	Existing	Proposed
No.of Slices	3160	3147
No.of 4 input LUTs	6297	6272



No.of Slice Flip Flops	68	65
No. of bonded IOBs	41	39

Fig. 12. Synthesize Report

## V. Conclusion

FCS-based multipliers keep up the info and yield operands of the Montgomery MM in the convey spare organization to escape from the arrangement change, prompting less clock cycles however bigger territory than SCS-based multiplier. To improve the execution of Montgomery MM while keeping up the low equipment many-sided quality, this paper has changed the SCS-based Montgomery increase calculation and professional represented a minimal effort and elite Montgomery secluded multiplier. The proposed multiplier utilized one-level CCSA design and skirted the superfluous convey spare addition operations to a great extent diminish the basic way delay and required clock cycles for finishing one MM operation. Trial comes about demonstrated that the proposed approaches are in fact fit for upgrading the execution of radix-2 CSA-based Montgomery multiplier while keeping up low equipment many-sided quality.

## VI. References

- [1] R. L. Rivest, A. Shamir, and L. Adleman, "A method for obtaining digital signatures and public-key cryptosystems," *Commun. ACM*, vol. 21, no. 2, pp. 120–126, Feb. 1978.
- [2] V. S. Miller, "Use of elliptic curves in cryptography," in *Advances in Cryptology*. Berlin, Germany:Springer-Verlag,1986, pp. 417–426.
- [3] N. Koblitz, "Elliptic curve cryptosystems," *Math. Comput.*, vol. 48, no. 177, pp. 203–209, 1987.
- [4] P. L. Montgomery, "Modular multiplication without trial division," *Math. Comput.*, vol. 44, no. 170, pp. 519–521, Apr. 1985.
- [5] Y. S. Kim, W. S. Kang, and J. R. Choi, "Asynchronous implementation of 1024-bit modular processor for RSA cryptosystem," in *Proc. 2nd IEEE Asia-Pacific Conf. ASIC*, Aug. 2000, pp. 187–190.
- [6] V. Bunimov, M. Schimmler, and B. Tolg, "A complexity-effective version of Montgomery's algorithm," in *Proc. Workshop Complex. Effective Designs*, May 2002.

[7] H. Zhengbing, R. M. Al Shboul, and V. P. Shirochin, "An efficient architecture of 1024-bits cryptoprocessor for RSA cryptosystem based on modified Montgomery's algorithm," in *Proc. 4th IEEE Int. Workshop Intell. Data Acquisition Adv. Comput. Syst.*, Sep. 2007, pp. 643–646.

[8] Y.-Y. Zhang, Z. Li, L. Yang, and S.-W. Zhang, "An efficient CSA architecture for Montgomery modular multiplication," *Microprocessors Microsyst.*, vol. 31, no. 7, pp. 456–459, Nov. 2007.

[9] C. McIvor, M. McLoone, and J. V. McCanny, "Modified Montgomery modular multiplication and RSA exponentiation techniques," *IEE Proc.- Comput. Digit. Techn.*, vol. 151, no. 6, pp. 402–408, Nov. 2004.

### Authors Details



**Sukanya Anumala Setty** has completed her B.Tech in Electronics and Communication Engineering from QIS Institute of Technology in 2016, JNTUK affiliated college. She is pursuing her M.Tech in VLSI and



Embedded Systems from QIS Institute of Technology, JNTUK affiliated college.

**Sai Sravanthi Gandham** is an Associate Professor at QIS Institute of Technology, Ongole. She received her B.Tech in Electronics and Communication Engineering from QIS College of Engineering and Technology, Ongole affiliated to JNTUK, M.Tech, in Digital Electronics Communication System from St. Ann's college of Engineering and Technology, Chirala affiliated to JNTUK.



**Mr. Shaik. Rahamtula** is currently working as Associate Professor in ECE Department, QIS Institute of technology, Ongole, A.P, India. He received his B. Tech degree in the department of Electronics and Communication Engineering, from KMCET (Affiliated to JNTU Hyderabad). He received his M. Tech from QIS college of Engineering and Technology (Affiliated to JNTU Kakinada). His research interests in the area of Face recognition, Content based image retrieval, Image compression, VLSI, ES.