

# *Automatic Drip Irrigation System through IoT*

Mr.DOKKA RAJASEKHAR  
VLSI&EMBEDDED SYSTEMS  
QIS INSTITUTE OF TECHNOLOGY  
Vengamukkapalem,  
Pondur Road,  
Ongole – PINCODE - 523 272

GUIDE Mr .P.PRAKASH MTECH  
QIS INSTITUTE OF TECHNOLOGY  
Vengamukkapalem,  
Pondur Road,  
Ongole – PINCODE - 523 272

## **Abstract**

Drip irrigation system makes the efficient use of water and fertilizer. Water is slowly dripped to the roots of the plants through narrow tubes and valves. Water is fed directly to the base of the plants which is a perfect way to water plants. For motor on and off we are using relay through IOT.

**Keywords:** Raspberry pi, Water pumping Motor, Relay

## **1. Introduction.**

India is the largest freshwater user in the world, and the country's total water use is greater than any other continent. The agricultural sector is the biggest user of water, followed by the domestic sector and the industrial sector. Groundwater contributes to around 65% of the country's total water demand, and plays an important role in shaping the nation's economic and social development.

The requirement of building an automation system for an office or home is increasing day-by-day. Automation makes an efficient use of

the electricity and water and reduces much of the wastage. Smart irrigation system makes the efficient use of water. This paper presents a smart irrigation system for agriculture farm with the use of devices like raspberry pi. Python programming language is used for automation purpose.

This paper contributes an efficient and fairly cheap automation irrigation system. System once installed has less maintenance cost and is easy to use[1]. It is more advantageous than the traditional agriculture techniques.

## **2. LITERATURE SURVEY**

### **1) R.Suresh et al. (2014)**

Mentioned about using automatic microcontroller based rain gun irrigation system in which the irrigation will take place only when there will be intense requirement of water that save a large quantity of water. These systems bring a change to management of field resource where they developed a software stack called Android is used for devices that include an operating system, middleware and key applications. The Android SDK provides the tools and APIs necessary to begin developing

applications on the Android platform using the Java programming language. Mobile phones have almost become an integral part of us serving multiple needs of humans. This application makes use of the GPRS feature of mobile phone as a solution for irrigation control system. These system covered lower range of agriculture land and not economically affordable.

[2]., with its powerful on-board processing, various sensors and other application specific devices can be integrated to it. In the system, sensors detect the water and moisture level and send readings to a fixed access point, such as a personal computer, which in turn can access irrigation modules installed in the field or the physical module in the water tank, wirelessly over the internet. A wireless application of drip irrigation automation supported by soil moisture sensors Irrigation by help of freshwater resources in agricultural areas has a crucial importance. Traditional instrumentation based on discrete and wired solutions, presents many difficulties on measuring and control systems especially over the large geographical areas. If different kinds of sensors (i.e. humidity, and etc.) are involved in such irrigation in future works, it can be said that an internet based remote control of irrigation automation will be possible

### 3. Implementation:

Automatic Drip Irrigation System Through IOT

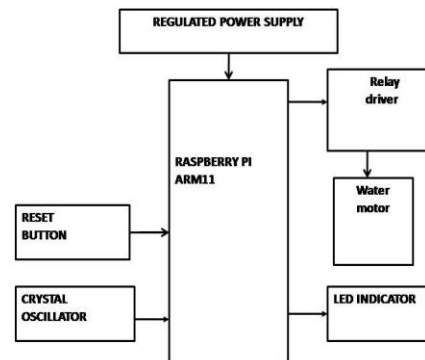

From the above figure, we can see that the device which is able to perform the task is a **Raspberry Pi** processor. There are different commands such as motor ON and OFF. The status is sent to android phone through Wi-Fi. To perform this task, **Raspberry Pi** processor is programmed using embedded 'Linux'.

### 4. Related Work:

The system depending on the charging circuit the motor can be controlled using relay switch. Then runs the motor through the relay switch. The system also shows the status of the motor is displayed on the android phone.

The brief introduction of different modules used in this project is discussed below:

### RASPBERRY PI 3



The board real estate savings compared to a parallel I/O bus are significant, and have earned SPI a solid role in embedded systems. That is true for most system-on-a-chip processors, both with higher end 32-bit processors such as those using ARM, MIPS, or PowerPC and with other microcontrollers such as the AVR, PIC, and MSP430. These chips usually include SPI controllers capable of running in either master or slave mode. In-system programmable AVR controllers (including blank ones) can be programmed using an SPI interface.

#### WIFI MODULE:

Wi-Fi or WLAN as it is commonly known is fast becoming the preferred mode of connecting to the internet. Many people are not aware of the descriptions and explanations related to it. Wi-Fi gets its name from a certification called Wireless Fidelity given to networks operating under 802.11 standards. Wi-Fi allows computers, PDAs and other devices to connect to a broadband connection in a wireless mode. The 802.11 standard

defines the wireless communication operating via electromagnetic waves. While reading the descriptions and explanations related to Wi-Fi, one should remember there are different modes for wireless networks like Infrastructure mode and Ad-Hoc mode that can be used for different criteria.

#### Water Motor:

An electric submersible pump (ESP) is a device which has a hermetically sealed motor close-coupled to the pump body. The whole assembly is submerged in the water to be pumped. Submersible pumps push water to the surface, as opposed to jet pumps, which have to pull water.



#### Relay:

A relay is an electrically operated switch. Many relays use an electromagnet to operate a switching mechanism, but

other operating principles are also used. Relays find applications where it is necessary to control a circuit by a low-power signal, or where several circuits must be controlled by one signal. A type of relay that can handle the high power required to directly drive an electric motor is called a contactor. Relays with calibrated operating characteristics and sometimes multiple operating coils are used to protect electrical circuits from overload or faults; in modern electric power systems these functions are performed by digital instruments still called "protection relays".

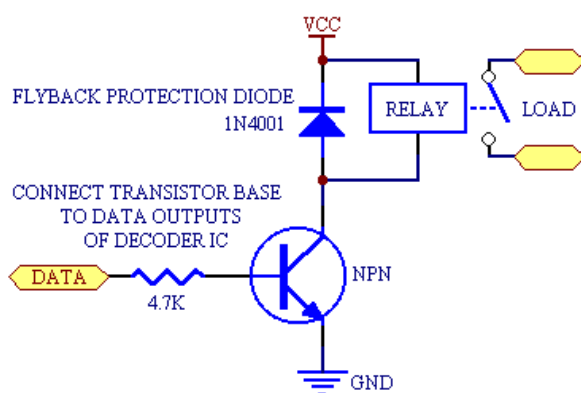
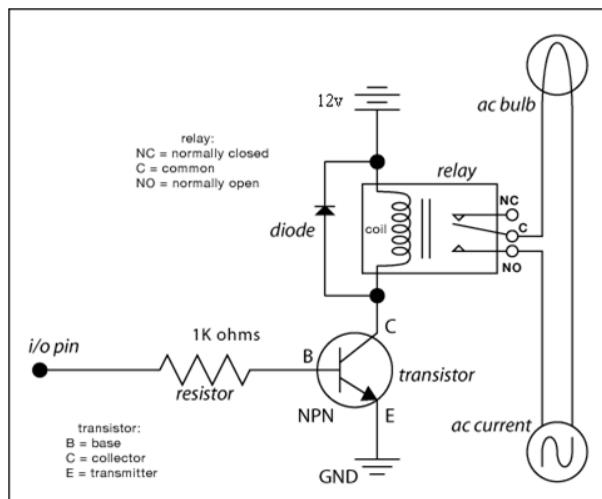

## 5. ACKNOWLEDGEMENT

We would like to thank all the authors of different research papers referred during writing this paper. It was very knowledge gaining and helpful for the further research to be done in future.

## REFERENCES

- [1] ChandankumarSahu, PramiteeBehera, "A Low Cost Smart Irrigation Control System", IEEE Sponsored 2nd International Conference on Electronics and Communication System (ICECS 2015)
- [2] G. Yuan, Y. Luo, X. Sun, and D. Tang, "Evaluation of a crop water stress index for detecting water stress in winter wheat in the North China Plain," *Agricult. Water Manag.*, vol. 64, no. 1, pp. 29-40, Jan. 2004.
- [3] Nikhil Agrawal Engineering Manager, Siemens, Noida nikhil.pa@gmail.com, SmitaSinghal ASET, Amity University, Noida singhal.smita@gmail.com, Smart Drip Irrigation System using Raspberry pi and Arduino, International Conference on Computing, Communication and Automation (ICCCA2015) ISBN:978-1-4799-8890-7/15/\$31.00 ©2015 IEEE.
- [4] R.Hussain, J.Seohal, A.Gangwar, M.Riyag "Control of irrigation automatically by using wireless sensor network" *International journal of soft computing and engineering*, vol.3, issue 1, march 2013, pp.48t 324-328.
- [5] Abreu VM, Pereira LS (2002). Sprinkler irrigation systems design using ISAMim. p. 022254

[6] Wireless Medical Technologies: A Strategic Analysis of Global Markets [online]. International Telecoms Intelligence.

[7] G. Y. Jeong, K. H. Yu, and Kim. N. G. Continuous blood pressure monitoring using pulse wave transit time. In International Conference on Control, Automation and Systems (ICCAS), 2005.

[8] K. Hung, Y. T. Zhang, and B. Tai. Wearable medical devices for telehome healthcare. In Process. 26th Annual International Conference on the IEEE EMBS, 2004.

[9] Fang, Xiang et al: An extensible embedded terminal platform for wireless telemonitoring, Information and Automation (ICIA), 2012 International Conference on Digital Object Identifier: 10.1109/ICInfA.2012.6246761  
Publication Year: 2012 , Page(s): 668 – 673.

[10] Majer, L., Stopjaková, V., Vavrinský, E.: Sensitive and Accurate Measurement Environment for Continuous Biomedical Monitoring using Microelectrodes. In: Measurement Science Review. – ISSN 1335– 8871. – Vol. 7, Section 2, No. 2 (2007), s. 20–24.

[11] Majer, L., Stopjaková, V., Vavrinský, E.: Wireless Measurement System for Non-Invasive Biomedical Monitoring of PsychoPhysiological Processes. In: Journal of Electrical Engineering. – ISSN 1335–3632. – Vol. 60, No. 2 (2009), s. 57–68.