

Z-Source Based Boost Dc-Dc Converter by Flyback and Voltage Multiplier

V.Rajasekhar¹, S.Baji², N.Hanuma Naik³

¹M.Tech Student, Dept of EEE, Sri Chundi Ranganayakulu Engineering College, Guntur, A.P, India.

²Associate Professor, Dept of EEE, Sri Chundi Ranganayakulu Engineering College, Guntur, A.P, India.

³Associate Professor&HOD, Dept of EEE, Sri Chundi Ranganayakulu Engineering College, Guntur, A.P, India

ABSTRACT:

At present in light of the contamination issues of the petroleum products, request of sustainable power sources is expanded. Sun powered boards and energy components create low voltage, subsequently high voltage step up dc-dc converters are expected to help their low yield voltage to meet the inverters required voltage. Z-source converter has a few points of interest, for example, high voltage step up, detached vitality source from the user side, clipped switch voltage and positive yield voltage extremity, in this manner it is an appropriate decision for high advance up applications. This paper presents a non-disengaged high advance up dc-dc converter which is the induction of z-source converter and has a higher voltage pick up in contrast with the traditional converters. This favorable position settles on this converter an appropriate decision for photovoltaic

applications. In addition, high lift voltage is gotten with low obligation cycle and the vitality of spillage inductances is consumed so the effectiveness is expanded. A 100 W research center model to change over 24-300 V is actualized to confirm the theoretical and simulation results.

I. INTRODUCTION

The principle purpose for the over the top carbon emanations is the intemperate ignition of non-renewable energy sources. Also, the ongoing instability of the oil costs since 2014 has likewise included a power behind the move from non-renewable energy sources towards the sustainable assets. Subsequently, ssil energizes issues can be considered after:

- Giant measures of carbon dioxide are discharged into the climate.

- Carbon dioxide prompts nursery impact or the worldwide warming.
- Coal-consuming stations discharge sulfur dioxide gas which causes to corrosive rain.
- Fossil energizes supplies are restricted and are not sustainable.

Be that as it may, they create the low yield voltage and the higher voltage is required for inverters input, so the request of utilizing high advance up dc-dc converters is expanded. The regular arrangement was to utilize the few PV cells in arrangement; nonetheless, due to the module crisscross and shadow impact of PV cells, the yield control is diminished.

Principle points of interest of the proposed converter can be consider:

- ❖ The converter has high voltage step up without expanding the turn proportion of coupled inductors.
- ❖ Four diodes of the converter are dead under zero current exchanging (ZCS) condition and two of them are turned on under zero voltage exchanging (ZVS) condition.

- ❖ The invert recuperation issue of yield diodes is wiped out.
- ❖ High voltage pick up can be accomplished for the low obligation cycle. ($D < 0.45$)
- ❖ Low pressure voltage of the semiconductor gadgets (the switch voltage is clipped).

II. PROPOSED CIRCUIT

Figure 1 demonstrates the z-source dc-dc converter topology. It comprises of two indistinguishable capacitors and two indistinguishable inductors in the z-source organize. Voltage step up proportion of this converter can be accomplished by:

$$M = \frac{V_0}{V_1} = \frac{1 - D}{1 - 2D} \text{ For } D < 0.5$$

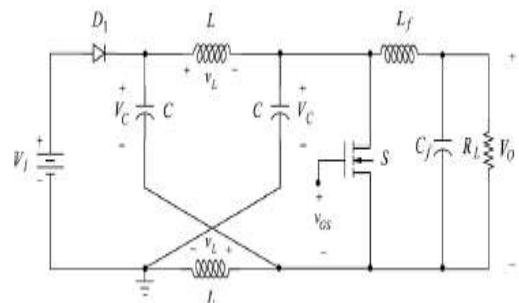

Fig.1. Z-Source Converter Topology.

The proposed converter topology is appeared in Fig. 2. Coupled inductors and voltage multiplier are utilized to

increment the voltage pick up of this converter. It has two primary working modes amid one exchanging period in the steadystate. It is accepted all the semiconductor gadgets are perfect, the converter works in CCM. The turn proportion of coupled inductors is characterized by $n = N_s/N_p$.

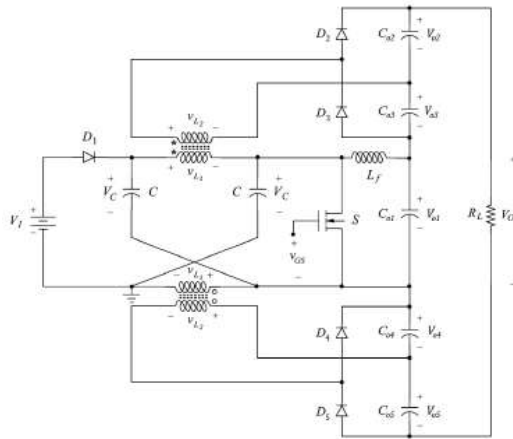

Fig2. Proposed Z-Source Converter Topology.

Mode 1:

This task mode is begun when dynamic switch S is turned on. At that point the information diode D1 is killed. So the principle dynamic switch S and the information diode of the proposed converter work in the corresponding way. At that point, the capacitors C voltage is connected over the inductors L1 and since this voltage is sure and

steady, inductors L1 current are expanded directly and with a consistent incline

.The turn proportion of the couple inductors L1 and L2 is characterized as $n = n_2/n_1$ in this way, n times of the voltage crosswise over inductors L1 is connected crosswise over inductors L2. This causes the D2 and D5 to be turned on. So the capacitors Co2 and Co5 are charged in this time interim. At the point when the diodes D2 and D5 are turned on, the negative voltage is connected crosswise over diodes D3 and D4 and makes these diodes to be killed. Since the channel inductor Lf voltage is negative in this task mode, the inductor current is diminished directly and it's vitality is lost.

These sets of equations including inductors voltage and diodes stress voltage can be written for this operation mode:

$$VL1 = Vc, VL2 = nVc \dots \dots \dots (2)$$

$$VLf = -V01 \dots \dots \dots (3)$$

$$V02 = V05 = VL2 = nVc \dots \dots \dots (4)$$

$$VD1 = 2Vc - V1 \dots \dots \dots (5)$$

Mode 2 :

This mode is begun when the turn S is killed. At that point the voltage crosswise over it

continue expanding till the information diode D1 is turned on. n times of L1 negative voltage is instigated over inductors L2 and after that diodes D3 and D4 are turned on and diodes D2 and D5 end up off. So capacitors Co3 and Co4 are charged. These arrangements of conditions including inductors voltage what's more, diodes and switch pressure voltage can be composed for this activity mode:

$$VL1 = V1 - Vc, VL2 = n(V1 - Vc) \dots \dots (6)$$

$$V03 = V04 = -VL2 = n(Vc - V1) \dots \dots (7)$$

$$Vs = 2Vc - V1 \dots \dots (8)$$

$$VLf = 2Vc - V1 - V01 \dots \dots (9)$$

III.PERFORMANCE COMPARISON

PV boards more often than not have ostensible voltage of 24 volts and energy of 100 watts. Additionally for 110 volts (rms) AC of utility, 300 volts DC input voltage is required for half-connect inverter also, for 220 volts (rms) AC of utility, 300 volts DC input voltage is required for full-connect inverter. If AC (rms) voltage of 120 Volts is required at the inverter yield, half extension inverter ought to be utilized with the information DC voltage of 300 Volts. In light of these realities, proposed dc-dc

converter is composed to change over 24 volts to 300 volts. In this segment, the proposed converter is contrasted and other dc-dc converters. the yield voltage of a 100 W PV board (24 volts DC) is changed over to 120 volts AC with the control handling unit . Thusly, a high advance up dc-dc converter is expected to change over 24 volts DC to 300 volts DC for the half extension inverter input. So the step up of 12.5 is required.

Table 1: Comparison with Other Converters

Converter	Voltage gain	Voltage stress	Reverse Recovery Problem
Boost	$\frac{1}{1-D}$	$\frac{Vin}{1-D}$	Large
Flyback	$n \cdot \frac{1}{1-D}$	$Vin \left(\frac{D}{1-D} + n \right)$	Large
Conventional z-source	$n \cdot \frac{1+D}{1-2D}$	$\frac{Vin}{1-2D}$	Small
Proposed z-source	$\frac{(2n+1)-D}{1-2D}$	$\frac{Vin}{1-2D}$	Small

IV.CONCLUSION

In this project, a novel high advance up z-source dc-dc converter with fly back and voltage multiplier is introduced. Inferred conditions demonstrate that voltage step up of traditional z-source converter is expanded significantly. The proposed converter has higher part check in contrast with other said converters, be that as it may, it wipes out the issue of unpredictability and incredible obligation cycle in traditional high advance up converters. In addition, low pressure voltage, high effectiveness also, extensive variety of voltage pick up by picking turn proportion, make it a decent contender for high advance up applications, such as expanding low yield voltage of sun based boards or other applications, for example, most extreme power point following and hang control in small scale matrix applications

REFERENCES

- [1] F. Z. Peng, "Z-source inverter," IEEE Transactions on industry applications, vol. 39.
- [2] A. Torkan, "Plan, reenactment and execution of a high advance up z-source dc-dc converter with flyback and voltage

multiplier," Master's proposition, Texas A&M University, 2016.

[3] M. B. Shadmand, R. S. Balog, and H. Abu-Rub, "Demonstrate prescient control of pv sources in a savvy dc appropriation framework: Maximum control point following and hang control," IEEE Transactions on Energy Change, vol. 29, no. 4, pp. 913– 921, 2014.

[4] M. Metry, M. B. Shadmand, R. S. Balog, and H. A. Rub, "Mppt of photovoltaic frameworks utilizing sensorless current-based model prescient control," IEEE Transactions on Industry Applications, 2016.



Veesa Rajasekhar was born in the year 1987. Present He is Pursuing his **M.Tech(PE)** in Sri Chundi Ranganayakulu Engineering College, Ganapavaram. Guntut(Dt.),A.P



S.BAJI was born in the year

1984. He obtained his **B.Tech** degree in Electrical and Electronical Engineering from Gayathri Vidya Parishad college of Engineering. He has completed **M.Tech** in Jawaharlal Nehru Technological University ,Hyderabad. Presently he is working as an Associate Professor in Sri Chundi Ranganayakulu Engineering ollege College, Ganapavaram, Guntur(Dt.),A.P



N.HANUMA NAIK was born in the year 1981. He obtained his **B.Tech** degree in Electrical and Electronical Engineering from Anil Neerukonda Institute of Science and Technology. He has completed **M.Tech** degree in St.Theresa Institute of Technology.Presentlyhe is working as a Head of the Department in Sri ChundiRanganayakulu Engineering College, Ganapavaram, Guntur(Dt.),A.P