

# Performance Enhancement Analysis of an Isolated Dc-Dc Converter Using Fuzzy Logic Controller

Boda Anusha<sup>1</sup>, Dr. R.Anand<sup>2</sup> & V.Ramudu<sup>3</sup>

<sup>1</sup> M Tech scholar in Electrical and Electronics Engineering in CMR College of Engineering and Technology.

<sup>2</sup> Associate professor in Electrical and Electronics Engineering in CMR College of Engineering and Technology.

<sup>3</sup> Assistant professor in Electrical and Electronics Engineering in CMR College of Engineering and Technology.

## ABSTRACT

High-intensity discharge lamp (HID), photovoltaic and fuel cell energy systems dc back-up energy systems and electric vehicles are the some industrial applications are required high voltage gain dc-dc converters. A Boost Converter is not able to obtain a high voltage gain even with extreme duty cycle. To increase the voltage gain for the new Boost converter from the solar power application, this project proposes usage of the coupled inductor and parallel capacitor from output side, so that more than 10 times of input voltage is produced. The proposed boost converter has a input voltage of 60V and produces output voltage of 600V and output power is 900 watts. The output voltage is increased, voltage stress across the active switch is reduced and output ripples are minimized. The converter is operated at first in open-loop mode and further connected with closed-loop manner with Fuzzy Logic Controllers using Mat lab/Simulink software.

**Keywords** – DC-DC Converter, Fuzzy Logic Controller, Coupled Inductor, Parallel Capacitor, High Voltage Gain.

## 1. INTRODUCTION

**Solar energy:** Solar energy is the most readily available energy source. He does not belong to

anyone and is therefore free. It is also the most important unconventional energy source because it is non-polluting and thus contributes to reducing the greenhouse effect.

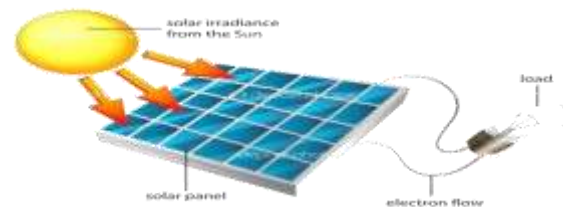

Solar energy

Sun oriented power has been utilized because of the reality ancient times, yet inside the most extreme primitive way. Before 1970, studies and improvement sketches transformed into completed in a few nations to influence additional proficient utilization of sunlight based to control, however the majority of this works of art remained fundamentally scholarly. After the sensational ascent in oil costs inside the 1970s, a few universal areas began to grow vast investigations and change projects to tackle sun control Sunlight based power is the brilliant gentle and warmth of the sun oriented that is abused the utilization of more than a couple of regularly changing advances. Including sun warming, photovoltaic, sun based warm quality, sun structure and fake photosynthesis.

It is a fundamental supply of inexhaustible power and its advancements are typically described as both detached sun and enthusiastic sunlight based, depending on how they seize and disperse sun oriented vitality or change over it to sun based quality. Dynamic sun oriented techniques incorporate utilizing photovoltaic frameworks, concentrated sun quality and sun water warming to saddle quality. Detached sun strategies include arranging a working toward the sun oriented, settling on substances with ideal warm mass or light disseminating properties, and outlining spaces that normally circle the air.

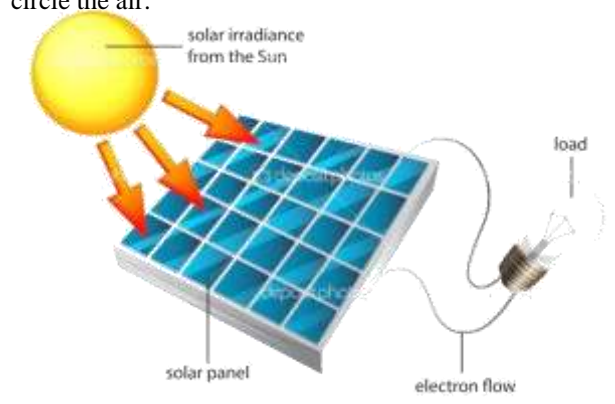

### Electricity production

**Solar Power:**-Sun based quality is the transformation of daylight into quality, either immediately utilizing photovoltaic (PV), or not straightforwardly the use of concentrated sun control

**Photovoltaic:**-Over the past two decades, photovoltaic (PV), additionally called sun PV, has advanced from an unadulterated specialty market of little projects to transforming into a standard vitality supply. A sun cell is a device that proselytes gentle immediately into quality the utilization of the photoelectric impact. The main sun versatile transformed into developed by utilizing Charles Frits in the 1880s. In 1931, a German architect, Dr. Bruno Lange, built up a photocell utilizing silver serenade in district of copper oxide. In spite of the fact that the selenium model cells changed substantially less

than 1% of episode mellow into quality, Ernst Werner von Siemens and James Clerk Maxwell analyzed the criticalness of this disclosure.

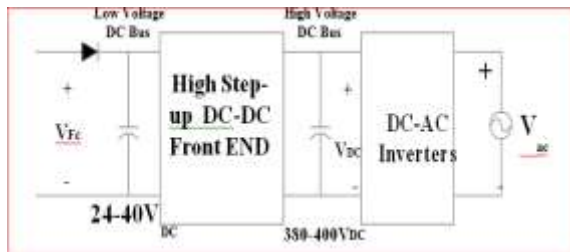

Fig 1.2 Photovoltaic

**Concentrated solar power:**-Sun oriented Energy Concentration Systems (CSP) utilizes focal points or mirrors and observing frameworks to acknowledgment a great part of the sunshine into a little bar. Concentrated warmth is then utilized as a warmth supply for a customary power plant. An immense scope of mindfulness advances exist;

**DC-DC Converters with High Step-Up Gain:**-High-upward pushes DC-DC converters are extensively used to blast the low enter voltage organize at the front of administered control structures. These frameworks are controlled by method for sustainable power sources which incorporates sun boards, batteries and energy units. Another form in private PV frameworks is to receive a parallel arrangement in inclination to serial association with meet insurance necessities while determining most energy to be had from PV boards. The enter voltage can run from 12 to 50 V and the yield voltage is typically 380V. An ordinary improve converter could have issue expanding enter voltage and holding high effectiveness simultaneously. At the point when exceptional high voltage pick up is required, the converter needs to work with an intemperate duty cycle. In any case, the parasitic protection of a lift converter will realize significant debasement of both the voltage transformation proportion and the execution. What's more, a diode with an inordinate voltage may likewise thought process extreme inverse recuperating inconveniences, so a further advanced damper or a synchronous switch with an unnecessary

ostensible voltage should be utilized. Lamentably, the expansion circuit or the exchanging device will blast the loss of the converter. Average secluded converters comprising of front, bring down back, push-pull, 1/2 extension and full scaffold sorts can pick up an over the top voltage transformation rate by means of changing the transformer proportion.



**General Power generation system with a high step-up converter**

General Power generation system with a high step-up converter An extreme ascent dc-dc converter is demonstrated in FIG. 1. Three with an included coupled inductor and an ordinary mode electromagnetic obstruction markdown get out. Here, a Sepik-fly back converter with a coupled inductor and a yield voltage stack is progressed. A high raise converter, which utilizes a coupled inductor and a voltage doublers approach at the yield voltage stack to accomplish an over the top pick up of raise voltage, is brought. A high lift improve converter that makes utilization of different coupled inductors for yield voltage stacking is provided.

What's more, advance up converters, which utilize an expansion in voltage, are conveyed. Since the exchange ought to have a high contemporary all through the enactment length, this system is appropriate for low vitality yield bundles. Since the low voltage rating and the low conduction protection RDS (on) of the quality exchange are utilized for these converters, the exorbitant change execution can be obtained. Be that as it may, the necessity of an inductor combined with an inordinate coupling coefficient will bring about assembling

issues and increased expenses. An intemperate advance up converter, which utilizes a tri-country exchanging portable and a capacitor-based absolutely voltage multiplier level, can receive a high reward of height

- AC/AC transformers
- AC/DC rectifiers
- DC/DC converters
- DC/AC inverters

**Types of dc-dc converters:-**There are numerous assortments of DC-DC converters, everything about tend to be more proper for specific assortments of uses than others. For comfort, they might be classified into various enterprises, be that as it may. For example, a few converters are reasonable handiest for bringing down the voltage, while others are best suitable for expanding the scope of converters. In this, we can most essential sorts of DC-DC converters. Presently, DC-DC converters can be isolated into sorts Non-remote DC-DC converters Isolated DC-DC converters

**NO-REMOVED DC-DC COVERTER:-**The un insulated converter typically utilizes an inductor, and there is no DC voltage segregation among the info and the yield. The full-estimate lion's share of projects doesn't require DC detachment between its info and yield voltages.

**BUCK CONVERTER:-**The down converter is the most generally utilized dc-dc converter topology in power administration and microchip voltage control (VRM) applications. These bundles require expedient rate and line transient reactions and unnecessary productivity over a broad scope of expense present day. They can change over a voltage source directly into a lower controlled voltage. For example, in a portable workstation contraction, the voltage must be decreased and a lower voltage must be kept up. For this intention, the Buck converter might be utilized. What's more, down converters offer longer battery presence for versatile frameworks that invests most extreme in their energy in rest mode. Buck controllers are frequently utilized as exchanging power assets for the baseband

virtual center and the RF control enhancer (PA).

**BOOST CONVERTER:-**A boost converter (boost converter) is a DC-DC power converter with an output voltage greater than its input voltage. It is a switched power class (SMPS) that contains at least two semiconductor switches (a diode and a transistor) and at least one energy storage element, a capacitor, an inductor or both in combination. Filters made of capacitors (sometimes in combination with inductors) are usually added to the output of the converter to reduce the ripple of the output voltage. The Basic schematic of a boost converter

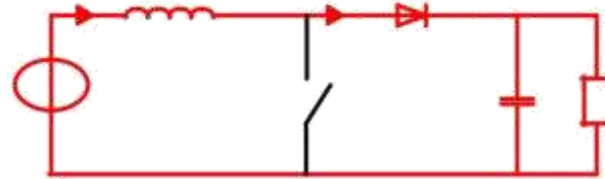

Two configuration of boost converter, depending on the state of the switch S

**Overview:-**The quality supply of the lift converter can originate from all reasonable DC resources, which incorporate batteries, sun powered boards, rectifiers and DC plants. A procedure that progresses a DC voltage to a remarkable DC voltage is known as DC to DC change. An expansion converter is a DC-DC converter with a yield voltage more than the source voltage. An expansion converter is from time to time called a lift converter as it "will build" the voltage of the supply. Since the vitality ( $P = VI$ ) must be chatted, the yield display day is not as much as the advanced of the source.

*Discontinuous mode*

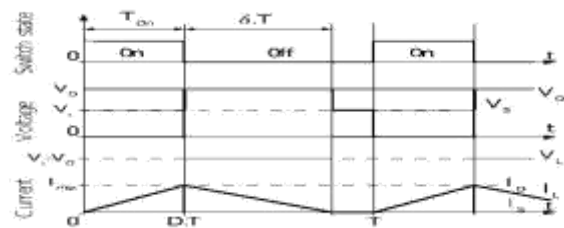

Waveforms of current and voltage in a boost converter operate in a batch mode. If the ripple amplitude of the current is too high, the inductor can be completely discharged before the end of a complete switching cycle. This usually happens under light loads. In this case, the current flowing through the inductor drops to zero during part of the period (see the waveforms in above Figure).

**History:-**For unreasonable execution, the SMPS exchange needs to turn on and off speedy and have low misfortunes. The coming of a business semiconductor switch inside the Nineteen Fifties transformed into a point of reference that made SMPS alongside the upgrade converter conceivable. The prevalent DC-DC converters have been progressed in the mid 1960s, while semiconductor switches wound up plainly accessible Overall diagram of Boost converter.



**BUCK-BOOST CONVERTERS:-**A basic buck-boost converter is shown in Fig 1.10. The average input current of this converter can be found according to its input current waveform.

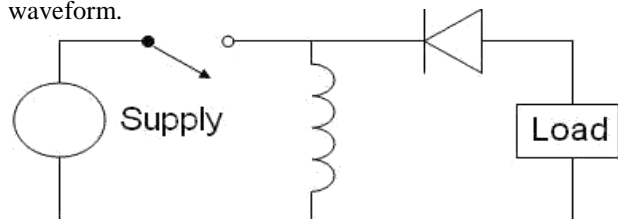

The buck-boost converter

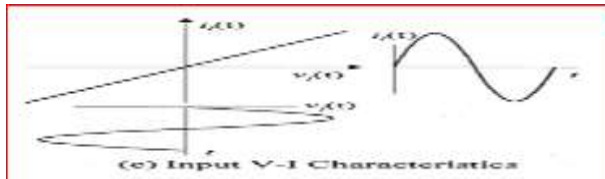
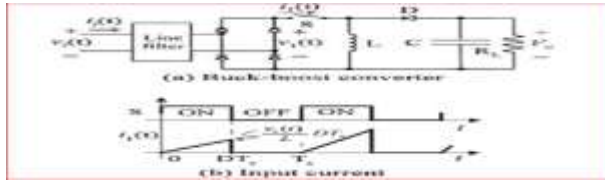

V-I characteristics of buck-boost converter

$$I_{Lon} = \int_0^{DT} dI_L = \int_0^{DT} \frac{V_i}{L} dt = \frac{V_i DT}{L} \quad \text{---(1.1)}$$

**Conceptual overview:** Like the buck and increment converters, buck-raise operation is higher comprehended in expressions of the "hesitance" of the inductor to permit a short exchange of present day. From the underlying country wherein nothing is charged and the exchange is open, the cutting edge coursing through the inductor is 0. At the point when the exchange is shut out of the blue, the closing off diode keeps the present day from streaming inside the best possible side of the circuit, with the goal that it must go through the inductor. Be that as it may, in light of the fact that the inductor does never again like fast present day modifications, it as a matter of first importance keeps the low present day through smothering most extreme of the voltage outfitted by utilizing the supply. After some time, the inductor will allow the front line to increment gradually by methods for diminishing its voltage drop. Then, the inductor will shop power inside the type of an attractive field From to, the converter is in state, so the s witch S is shut. The rate of interchange of the inductive contemporary (IL) is consequently given with the guide of

$$\frac{dI_L}{dt} = \frac{V_i}{L} \quad \text{---(1.2)}$$

**At the end of the On-state, the increase of IL is therefore:** D is the duty cycle. It represents the fraction of the commutation period T during which the switch is on. Therefore D ranges between 0 (S is never on) and 1 (S is always on). During the Off-state, the switch S is open, so the inductor current flows through the load. If we assume zero voltage drop in the diode, and a capacitor large enough for its voltage to remain constant, the evolution of IL is:

$$\frac{dI_L}{dt} = \frac{V_o}{L} \quad \text{---(1.3)}$$

Therefore, the variation of IL during the Off-period is:

$$\begin{aligned} \Delta I_{LOH} &= \int_0^{(1-D)T} dI_L \\ &= \int_0^{(1-D)T} \frac{V_o dt}{L} = \frac{V_o(1-D)T}{L} \quad \text{---(1.4)} \end{aligned}$$

As we consider that the converter operates in steady-state conditions, the amount of energy stored in each of its components has to be the same at the beginning and at the end of a commutation cycle. As the energy in an inductor is given by

$$E = \frac{1}{2} L I_L^2 \quad \text{---(1.5)}$$

It is obvious that the value of IL at the end of the off state must be the same as the value of IL at the beginning of the On-state, i.e. the sum of the variations of IL during the on and the off states must be zero:

$$\Delta I_{Lon} + \Delta I_{Loff} = 0 \quad \text{---(1.6)}$$

$$\Delta I_{L\text{on}} + \Delta I_{L\text{off}} = \frac{V_i D T}{L} + \frac{V_o (1-D) T}{L} = 0 \quad (1.7)$$

This can be written as:

$$\frac{V_o}{V_i} = \frac{(-D)}{(1-D)} \quad (1.8)$$

This in return yields that:

$$D = \frac{V_o}{V_o - V_i} \quad (1.9)$$

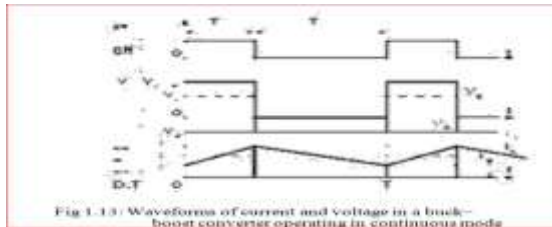

Waveform of current and voltage in a buck-boost converter

**Discontinuous mode:** In some cases, the amount of energy required by the load is small enough to be transferred in a time smaller than the whole commutation period. In this case, the current through the inductor falls to zero during part of the period. The only difference in the principle described above is that the inductor is completely discharged at the end of the commutation cycle. Although slight, the difference has a strong effect on the output voltage equation. It can be calculated as follows: As the inductor current at the beginning of the cycle is zero, its maximum value

$$I_{L\text{max}} \text{ (at } t=DT) \quad (1.10)$$

$$I_{L\text{max}} = \frac{V_i D T}{L} \quad (1.11)$$

$$I_{L\text{max}} + \frac{V_i \delta T}{L} = 0 \quad (1.12)$$

During the off-period,  $I_L$  falls to zero after  $\delta T$ : Using the two previous equations,  $\delta$  is:

$$\delta = \frac{V_i D}{V_o} \quad (1.13)$$

The load current  $I_o$  is equal to the average diode current ( $I_D$ ). As can be seen on figure 1.12, the diode

$$I_o = I_D = \frac{I_{L\text{max}} \delta}{2} \quad (1.14)$$

current is equal to the inductor current during the off-state. Therefore, the output current can be written as:

$$I_o = \frac{V_i D T V_i D}{2 L V_o} = \frac{V_i^2 D^2 T}{2 L V_o} \quad (1.15)$$

Replacing  $I_{L\text{max}}$  and  $\delta$  by their respective expressions yields: Therefore, the output voltage gain can be written as:

**SOFT SWITCHING TOPOLOGIES:** In customary extreme cycle PWM converters, wherein the current and voltage beats interchange from an unreasonable cost to a minimal effort or a low to high expense all through the progress time frame, an exchanging misfortune happens. Likewise produces a sizable amount of electromagnetic impedance. These misfortunes happen because of the transistor yield capacitor, the diode capacitance, and the turnaround recovery of the diode. From critique, we see that the exchanging misfortune is specifically relative to the exchanging recurrence. In this way, the higher exchanging misfortune confines the changing recurrence to an insignificant cost. Because of the broad ghostly scope of music blessing in the PWM waveform, high electromagnetic impedance

(EMI) happens. Current tops because of diode rebuilding can likewise cause this electromagnetic impedance

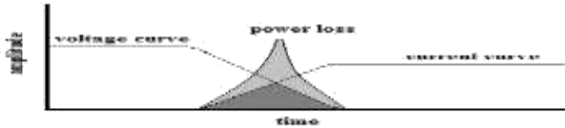

### Hard Switching Phenomenon

Delicate exchanging procedures can lessen exchanging misfortunes and electromagnetic obstruction by putting a little strain on the gadgets. At the point ZVS is used during turn ON of the device. Initially the main switch is OFF and the auxiliary switch is ON. So the current through the main switch is zero but the voltage is not zero. During the turn ON, voltage is made zero and current is given some time delay so that the current will begin to rise after the voltage is zero. when the current or voltage is zero amid the initiation or deactivation period, the result of voltage and current winds up plainly zero, which prompts a zero power misfortune. Consequently, the exchanging misfortune can be disposed of and the gadget can work at a high exchanging recurrence. The size and weight of the gadget are lessened since the warmth sink isn't required.

The sorts of delicate exchanging methods are:

- I. Zero voltage exchanging (ZVS)
- II Zero current exchanging (ZCS)

**I. Zero voltage exchanging (ZVS):**-ZVS is used during turn ON of the device. Initially the main switch is OFF and the auxiliary switch is ON. So the current through the main switch is zero but the voltage is not zero. During the turn ON, voltage is made zero and current is given some time delay so that the current will begin to rise after the voltage is zero.

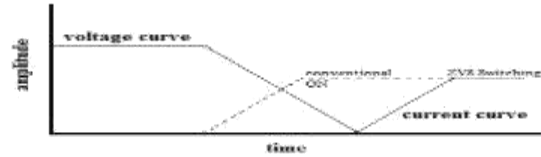

### Zero Voltage Switching (ZVS)

### Zero current switching (ZCS)

In this technique, the switching takes place at zero current condition.

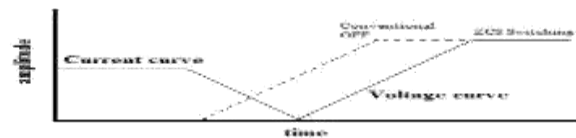

### Zero Current Switching (ZCS)

It is used at turning OFF of the device. Initially the device is conducting. So the current through the device is not zero but the voltage across it is zero. In ZCS condition, the current is made to zero and the voltage is allowed to rise after the current becomes zero.

## 2. LITERATURE SURVEY

### Cascade Cockcroft–Walton Voltage Multiplier Applied to Transformer less High Step-Up DC–DC Converter:-

As of late, the inside and out utilization of electrical contraption has forced high needs on electrical power, and this design is continually expanding. Subsequently, analysts and governments round the world were attempting endeavors on sustainable quality bundles to moderate home grown quality utilization and ecological issues. Among the differing wellsprings of inexhaustible power, the photovoltaic (PV) cell and the fuel cell have been thought about as appealing determinations. Notwithstanding, with the no-course settings, the yield voltages created through each are of a rather low degree. Subsequently, a high upward push dc-dc converter is wanted inside the quality change structures comparing to those power sources.

Notwithstanding the above applications, a high-upward push dc-dc converter is additionally required with the guide of numerous modern projects, alongside high-profundity release light balances for car headlights and battery release structures for control substances without interference

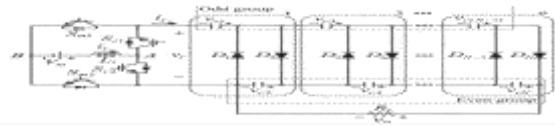

**Proposed converter with n-stage CW voltage multiplier**

**Novel Non-isolated High-Voltage Gain DC-DC Converters Based on 3SSC and VMC [2]:**-The regular raise converter can be brilliant for mounting bundles that don't require a high voltage advantage, particularly because of the subsequent low conduction misfortune and design execution. Hypothetically, the static favorable

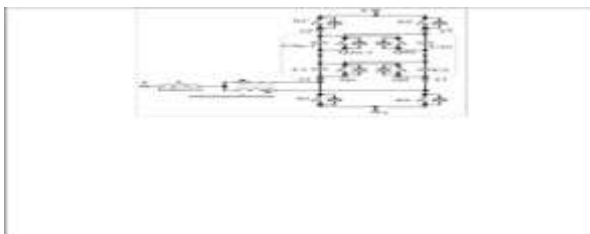
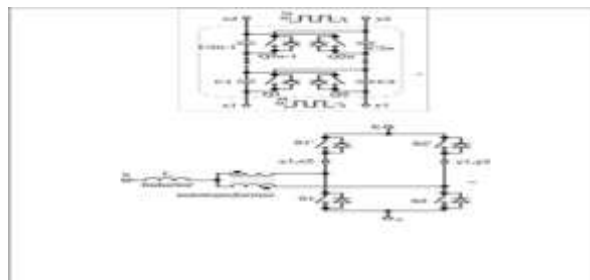

**a) Voltage multiplier cell. (b) Three-state switching cell. (c) Resulting cell.**

**A non-invert Buck-Boost DC-DC switching converter with high efficiency**

**and wide bandwidth:**-In many applications such as battery charging and discharging, power factor correction, fuel cell regulation and solar power point tracking, a DC-DC converter is used to achieve regulated voltage. When the regulated voltage is within the voltage of the unregulated voltage source, an up / down-DC converter is required. Step-up / step-down dc-dc converters with a single active switch, such as the buck-boost, fly back, septic and Cuk topologies have high component constraints and low efficiencies in the same operating point as the boost converter. or buck. the voltage is greater or less than the input voltage, respectively.

**Operating modes of the buck-boost converter: (a) boost mode (b) buck mode**

**3. PROPOSED CONCEPT**

**Introduction:** - As of late, the gigantic utilization of electrical framework has forced stringent necessities for the utilization of electrical power and this improvement is consistently expanding. As a final product, scientists and governments around the globe have sorted out sustainable power source bundles for informative home grown power utilization and the appropriation of the earth. Among the different sustainable power sources, the photovoltaic cell and the gas cell have thought about an alluring inclination. In any case, without extra arrangements, yield voltages produced from the two assets. Along these lines, an exorbitant pitch dc-dc converter is favored inside the power change frameworks comparing to those vitality assets. Notwithstanding the applications expressed, an over the top ascent dc/dc converter is moreover



required by means of numerous business applications, comprehensive of high-profundity release light counterweights for self-moving projectors and battery reinforcement frameworks for vitality loosened operation. Cut off.

**Interleaved Boost Converters:-**The inter converted buck and enhance converters were studied in current years that allows you to enhance the overall performance of the electricity

**Coupled inductance:-**Intentional center holes are the principle source of leakage flux in the power garage inductor. Apart from the windings, the go with the flow related to the leak takes a shorter direction (that is to mention within the air) and is consequently decoupled. The flux associated with the inductor moves in all the windings and most of it stays inside the core. In the environment, where windings percentage the DC present day similarly, a flow-canceling reverse-coupled configuration is used by implementing windings having opposite polarity. At the heart at once underneath the windings of N turns every, The

$$\frac{(1-K)LI_0}{N} \text{----- (3.1)}$$

Resultant flux is Where, I<sub>0</sub> is dc current through the winding.

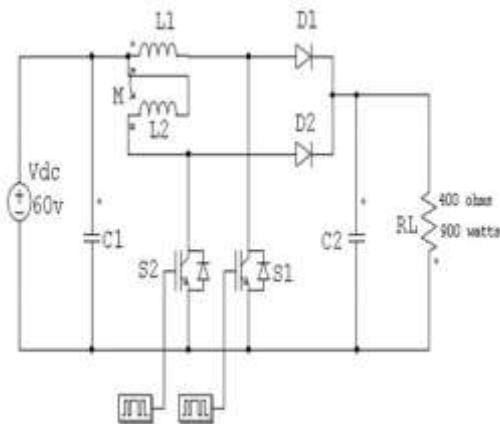

**Circuit Configuration of the Proposed Converter**

**MODE I: (t=t0 to t1 for S1& t=t2 to t3 for S2)** :-In this transition interval, from the figure 2the switch S1 is going to turned ON at t=0 but S2 is already maintained conduction is to be extended to reach at t=t3 the L2 is fully energized and C1 also got fully charged but L1 have 1/3 level of energy stored in the Inductor L1 at t=t1. In this mode1 duration C2capacitor discharge the energy to the load. DiodesD1 and D2 are turned OFF, so supply voltage is not present on the output load.

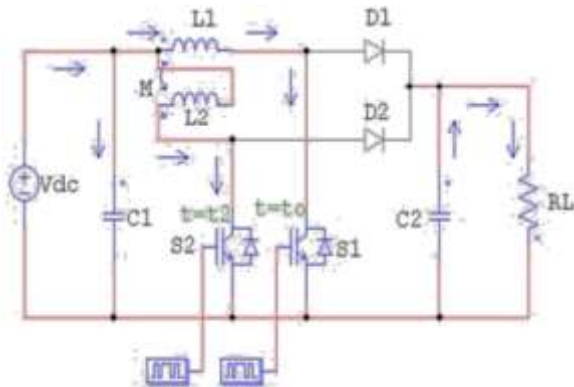

**Mode 1 circuit diagram**

**MODE II: (t=t1 to t2 for S1& t=t3 to t4 for S2):-** in this transition period, Fig 3.3 will be switched off at t = t3 but the already S1 maintain the conduction is that the torch is stretched at t = t2, and the L1 is 2/3 the energy level is energized and the full C1 capacitor is in discharge through L2 and D2 to load In this C2 charge is obtained but L1 has 2/3 LEVILOV energy stored in L1 inductor at t = t2. In this mode 2 the duration of capacitor C1 and L2 power inductors charges to load using diodes D2and is running D1-Off because S1 is contend conduction

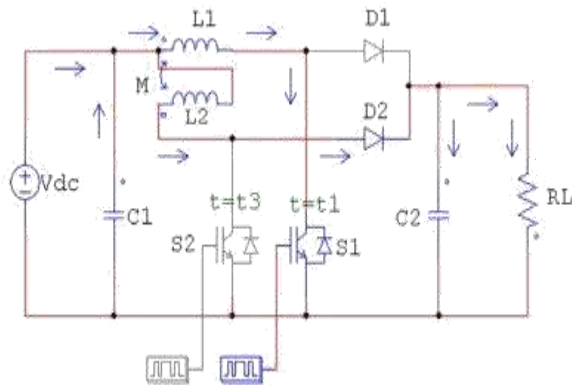

Mode 2 Circuit Diagram

**MODE III: (t=t2 to t3 for S1 & t=t0 to t1 for S2):**-In this transition period, the figs of the s3.3 switch will turn en at t = 0 but the already S1 maintain the conduction is that the truism extension at t = t3 is fully activated. L1 and C1 are also God fly charged but the L2 has 1/3 level stored energy In the L2 inductor at t = t1. In this mode 1 C2capacitor duration discharges the power into the load. DiodesD1 and D2 are turned off, so the display voltage is displayed on the output load

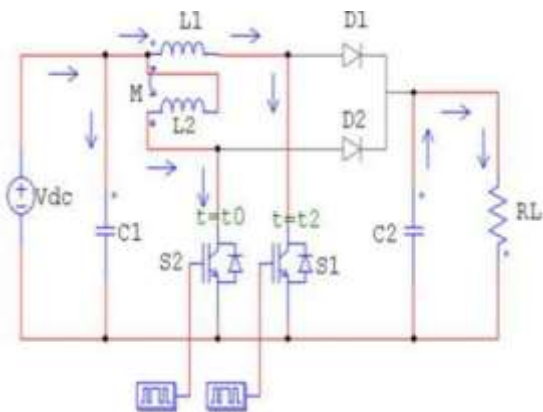

Mode 3 circuit diagram

**MODE IV: (t=t3 to t4 for S1 & t=t1 to t2 for S2):**-In this transition period, the fig from the 3.5 s2 switch will turn en at t = 0 but the already S1 maintain the conduction is that the torship span at t = t3 is fully activated. L1 and

C1 are also God fly charged but L2 has 1/3 level stored energy In the L2 inductor at t = t1. In this mode 1 C2capacitor duration discharges the power into the load. DiodesD1 and D2 are turned off, so the display voltage is displayed on the output load.

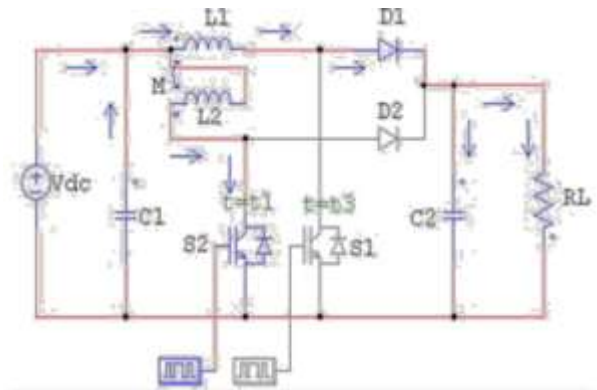

Mode 4 circuit diagram

**Analysis of the Proposed Converter:-**  
Basic formula for boost converter is given as,

$$\frac{V_{OUT}}{V_{IN}} = \frac{1}{1-D} \text{ -----(3.2)}$$

The mutual inductance is M and the self inductance are consider to be equivalent value of Land the coupling factor (k) is defined as M/L. Coupled inductor acts as a Transformer for the circuit diagram and each winding voltage and current relationship is given below. We have derive the terms of flux in the above equation

$$V_1 = (L-M) \frac{di_1}{dt} - M \frac{di_1 - di_2}{dt} \text{ --} \text{_(3.3)}$$

$$V_2 = (L-M) \frac{di_2}{dt} - M \frac{di_1 - di_2}{dt} \text{ ---} \text{_(3.4)}$$

$$I_{DC} = \frac{V}{R} \text{-----} \quad \text{_(3.5)}$$

$$V = L \frac{di}{dt}; \frac{V}{L} = \frac{di}{dt}; \frac{V_{in}}{L} = \frac{di}{dt} \text{-----} \quad \text{_(3.6)}$$

$$\frac{V_{in} - V_{out}}{L} = \frac{di}{dt} \text{-----} \quad \text{_(3.7)}$$

THIS CAN BE WRITTEN AS:

$$2 \Delta I_L = \frac{V_{in}}{L} DT_S \text{-----} \quad \text{_(3.8)}$$

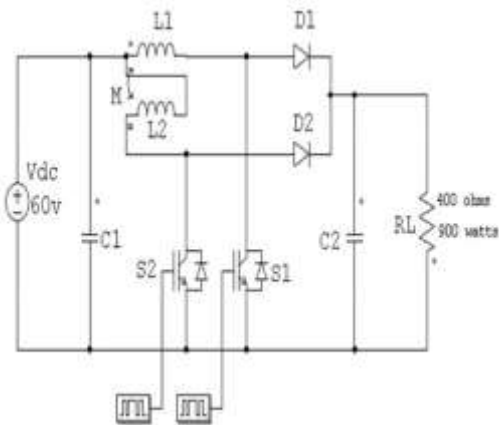

$$\Delta I_L = \frac{V_{in}}{2L} DT_S \text{-----} \quad \text{(3.9)}$$

$$\int_0^{T_S} i_C(t) dt = \left(-\frac{V}{R}\right) DT_S + \left(L - \frac{V}{R}\right) DT_S \text{-----} \quad \text{(3.10)}$$

Each winding has a DC current so that find the steady state current by using below equation, from the waveform divided into two intervals.

**Subinterval:** The inductor current formula is given as,

**Subinterval:** 2 for coupled inductor ripple current is given as,

Based on the waveforms, we have to drive capacitor current for the mode of operation of the circuit diagram. Equation 3.11 equal to zero, so we have to drive the current From the boost converter, we have to drive current for the mode of operation of the circuit diagram.

$$I = \frac{V_{in}}{RD^2} \text{-----} \quad \text{_(3.11)}$$

We can say that DC current is given as,

$$I_{DC} = \frac{V_{in}}{2R_L D^2} \text{-----} \quad \text{(3.12)}$$

(In terms Of Coupled Inductor)

$$I_{DC} = \frac{V_{in}}{2R_L(1-D)^2} \text{-----} \quad \text{(3.13)}$$

From this, we can say inversely coupled peak to peak inductor ripple current is,

#### 4. MATLAB AND SIMULINK MODEL

##### INTRODUCTION TO MATLAB

**MATLAB** At first created by an instructor in 1970 to enable understudies to learn direct variable based math. Was letter was promoted and additionally created under the Mathematics Works Company (established in 1984) [www.mathworks.com](http://www.mathworks.com). Mat lab is a product bundle that can be utilized to perform investigation and take care of numerical and building issues. It has brilliant programming highlights and designs ability - simple to learn and adaptable. Accessible in many working frameworks - Windows, Mace touch, Onyx, Dust has a few tool kits to tackle particular issues.

**MATLAB** (Lab Matrix) is a multi-registering computerized figuring condition and fourth era programming dialect. The restrictive programming dialect created by Mathurex, MATLAB permits control of grid, plotting of capacities and information, execution of calculations, production of UIs, and connecting with programs written in different dialects, including C, C ++, Java, Fortran and Python

**SIMULINK**:-Semulink, created by Math works, is a graphical programming condition for displaying, reenactment and investigation of multi-band dynamic frameworks. The fundamental interface is a diagram graph square device and an adaptable arrangement of piece libraries. It furnishes tight incorporation with whatever is left of the mat lab condition and can either be pushed matlab or be composed from it. Simulink is generally utilized as a part of computerized control and advanced flag preparing to recreate multi-dimensional and show based outline.

Used to display, break down and recreate dynamic frameworks utilizing piece patterns. Completely incorporated with Mat lab, simple and quick to learn and adaptable. Contains a complete piece library which can be utilized to reproduce straight, nonlinear or discrete frameworks - C codes can be made for phenomenal simulink models for implanted applications and brisk models for control frameworks

**Simulink and his association with Mat lab**:-Mat lab and Semulink situations are coordinated into one element; consequently we can investigate, reenact, and refine our models in any condition at any minute. We call Simulink from into Mat lab. MATLAB is an intelligent programming dialect that can be utilized as a part of numerous ways, including information investigation, perception, re creation and designing critical thinking. It can be utilized as an intelligent instrument or as an abnormal state programming dialect. It gives a productive situation to both, architect and expert. Simulinchem is an augmentation of Mat lab which gives an eco geographic programming condition to settling differential conditions and other dynamic frameworks.

## 5. MATLAB/SIMULINK CIRCUIT DIAGRAM AND RESULTS

### MATLAB/SIMULINK MODEL OF DC-DC CONVERTER IN OPEN-LOOP METHOD

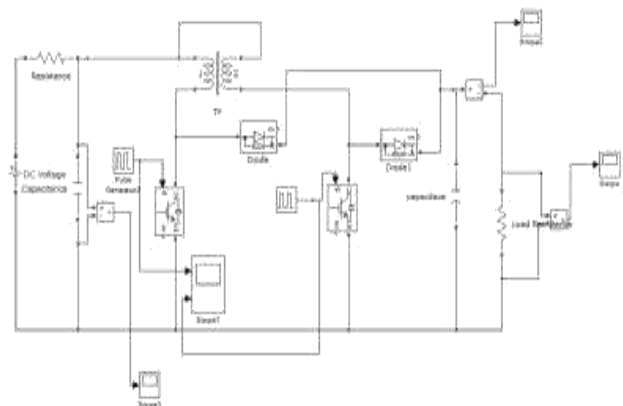

Mat lab/simulink model in open loop method

### MATLAB/SIMULINK MODEL OF DC-DC CONVERTER IN CLOSED-LOOP METHOD WITH FUZZY LOGIC CONTROLLER:-

Mat lab/simulink model in closed-loop method fuzzy logic controller

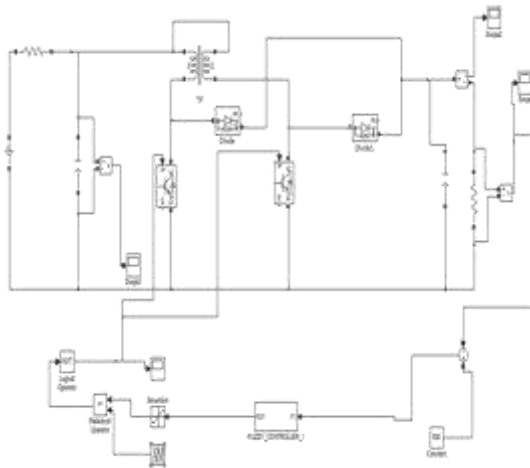

Mat lab/simulink model in closed loop method

**OPEN LOOP INPUT VOLTAGE**



Open loop input voltage

**OPEN LOOP OUTPUT CURRENT:-**

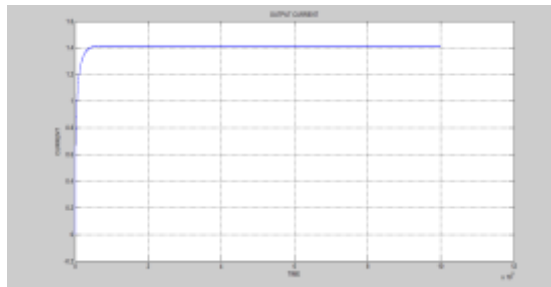

Open loop output current

**FUZZY LOGIC CONTROLLER OUTPUT CURRENT**

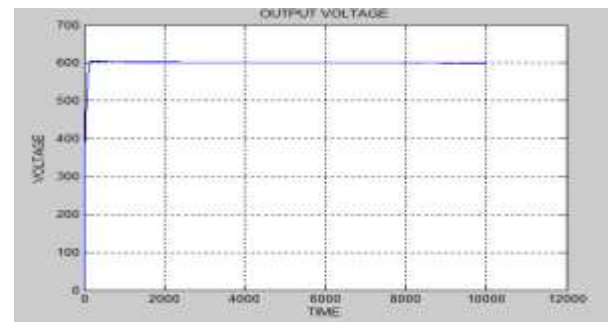

Fuzzy logic controller output voltage

**OPEN LOOP OUPUT VOLTAGE**

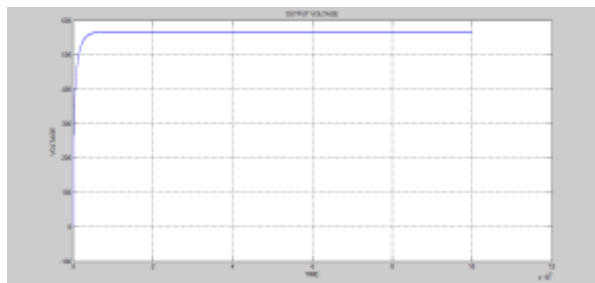

Open loop output voltage

**FUZZY LOGIC CONTROLLER OUTPUT CURRENT**

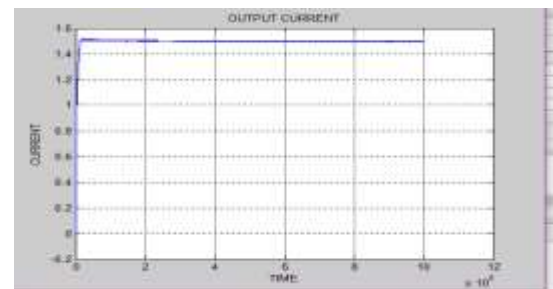

Fuzzy logic controller output current

**FUZZY LOGIC CONTROLLER INPUT CURRENT**



**Fuzzy logic controller input voltage**

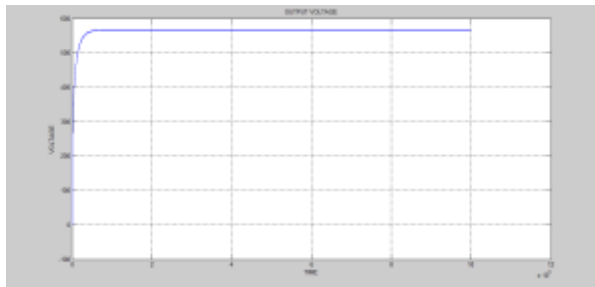

**voltage across c2 capacitance**



**voltage across c1 capacitor**

**6. CONCLUSION AND FUTURE SCOPE**

In this venture the DS-DSS changes another countervarsity alongside the inductor of the sun powered bueraplections. This needs to accomplish a high advance - Oblate pick up by changing the turn proportion of the accepted inductor and the capacitor and other proper

rating of all parameters. It is re-cycled vitality put away in the inductor spillage of the New Cube inductor giving high effective over bossed transformation. Moreover, the voltage cross switch is constrained into bring down voltage rating, and the new connector gets a lower resin which for better effectiveness. This high-effectiveness topology accommodates sun powered related bio energy ions identified with sustainable power source, and Is also can be effortlessly reached out to other Pure conversion framework to meet high Voltage made. In my future work of this paper has to go for the implementation of high power output from the low voltage input of the circuit diagram and this circuit has to add the inverter circuit for the purpose of AC loads application.

**7. REFERENCES**

[1]. Zhong Ming Yong, Ming Hui Chen, Tsun-Anchang, Chun Chu-ku, and Ku-Kwang Jin, "Course Cochroft-Walton Voltage Multiplier connected to transformer," *Interazakctions on Industrial Electronics*, Vol. 60, no. 2, Viberware 2013, b. 523-537.

[2]. Fernando Lisatovoli, Demersil de Souzaulivera, Jr., René Pastor Torrico-Pascope, and Yvelenganith Acosta Alcazar, "High-voltage Novellnysolated Dess-Deconstructers Based on 3SSC and Your Mouth," *Transactions on Energy Electronics*, Vol. 27, no. 9, September 2012, pp.3897-3907.

[3]. Tsai Fu Wu, Yu Sheng Lai, Jin-Quan Hang, Yao Ming-Chen, Post-Contrinter, Octopus Engines and Back-Post Type of Active Clamp, *IE Transports on Industrial Electronics*. 55, No. 1, January2008, pp. 154-162.

[4]. Hyun-Lark-du, "Changing Soft Ds/Deconstructers with High Gain Capacitance," *Transactions on Energy Electronics*, Vol. 25, no. 5, May 2010, pp.1193-1200.

[5]. Carlos Restrepo, Javier Calvent, Angel Sedbastor, Abdul Aali Alrodi, and Robertogirl, "Changing Nunnfering Buck Batch Desuying with High Efficiency Andoid Bandwidth", *Ie*



Transactions Unfor Electronics, Vol. 26, No. 9, September2011, pp. 244-2503.

[6] Yeplinganith Acosta Alcazar, Demersel Desusa Oliveira, Jr., Fernandolisatovoli, and René Pastor Torrico-Bascope, "Dess-Donnysolated Post Conformer Based on a Three-Stat Switch Cell and Voltage Multiplayer Cells, E-Transit Independent Electronic, Foul. 60, No.10, October2013, pp. 4438-4449.

[7]. Wuhua Li, Lingli Fan, Ye Zhao, Xiangning Hu, Dewey Xu, and Bin Wu, "High-advance development and exceptionally productive energy unit control age framework with Active Clamp FLEBAK FORDORCONFERTER", IE Transactions on Industrial Electronic, Vol. 59, No.1, Janori 2012, pp. 996-610.

[8]. Wuhua Li, Li Wuxhen, Xiangning Hu, Davidso, Ben Wu, "General deduction law of highspeed advance up interleaved converters withworked in connector", Transactions on

Industrial Electronics, Vol. 59, no. 3March 2012, PP.1650-1661.

[9]. Bor-Ren Lin, Fang Yu Hsieh, "Soft switching Zeta-Flippack Adapter with APOC Batch Type Active Clamp," Transactions on Industrial Electronics, Vol. 54, no. 5, October 2007, pp. 2813-2822.

[10]. Chen Xie-ming, Tsurung-Ju Liang, Yang Longsheng, and Jian-Fu Chen, "A Post converter with Capacitor Multiplexer and Cubeld Inductor for AS Modulapplications," IE Transactions on Industrial electronic, Vol. 60, No. 4, April 2013, pp. 1503-1511.

[11]. Ku Qing Zeng, Chi Chih-huang, and Xian Yamuna, "High-review transformer converter with photletage [11]. Multiplier module for photovoltaic framework", IE exchanges on PowerElectronicX, Vol. 28, No. 6, June 2013, pp. 3047-3057.