

A Novel Coupled Inductor Based Boost Converter Fed Dc Motor Drive

AJAY KUMAR

M. TECH STUDENT
DEPARTMENT OF PE
SSJ ENGINEERING COLLEGE

K. SURESH KUMAR

ASSOCIATE PROFESSOR
DEPARTMENT OF EEE
SSJ ENGINEERING COLLEGE

S . JAGADEESH

ASSOCIATE PROFESSOR
DEPARTMENT OF EEE
SSJENGINEERING COLLEGE

ABSTRACT

In this paper, a coupled inductor based high step-up dc–dc converter for high step-up applications is proposed. The concept is to utilize two capacitors and one coupled inductor. The two capacitors are charged in parallel during the switch-off period and are discharged in series during the switch-on period by the energy stored in the coupled inductor to achieve a high step-up voltage gain. In addition, the energy stored in the coupled inductor is recycled; the voltage stress of the main switch is reduced. The switch with low resistance $R_{DS(ON)}$ can be adopted to reduce the conduction loss and the reverse-recovery problem of the diodes is alleviated. Not only lower conduction losses but also higher power conversion efficiency is benefited from lower turns ratios. The operating principle and steady-state analyses are discussed in detail. Finally, A 200W Converter Operating at 50KHZ is presented to demonstrate the performance. The results are verified through MATLAB Software.

INTRODUCTION

Renewable energy sources (RES) have experienced a fast development in recent years. These systems employ with micro sources like PV, fuel cells etc. Though PV cells can be made into array and connected in series to produce high voltage there exist serious problems like shadowing effects, short circuit which drastically reduces its efficiency. In order to overcome such adverse effects this micro source energy is utilized by the high step up converter to produce high voltage and satisfy the demands. Conventional boost converters can't provide such a high DC voltage gain for extreme duty cycle.

Thus high step up dc-dc converters are used as front end converters to step from low voltage to high voltage which are required to have a large conversion ratio, high efficiency and small volume (Q. Zhao and F. C. Lee., 2003). In some converters active clamp circuit is used to overcome voltage spikes caused by the leakage inductance of the coupled inductor. Though ZVS technique is employed for

soft switching it can't sustain light loads (T.F. Wu, and B. Axelrod., 2008). Low level voltage from the PV, fuel cells is connected to Kilo watt level using step up dc-dc converter and inverter circuits.

Voltage spikes and switching losses are eliminated by active clamping. In dc-ac, inverter always tends to draw ac ripple current at twice the output frequency. Resonant inductors cost and circuit volume is high (R.J. Wai., 2008). In some converters high voltage conversion is obtained by changing transformer turns ratio which will increase the overall efficiency but still the operation of main switch involves hard switching and also EMI noise gets raised (J.M. Kwon and B.W. Kwon., 2009).

Impacts of SiC (silicon carbide) MOSFETS on converter, switching and conduction losses are reduced even though fast switching is done. Si diodes have ideal, but still SiC devices processes large amount of ringing current at turn OFF relatively to other devices. Package of external diode and the diode itself have more parasitic capacitances that are added to the devices parasitic aggravating the ringing (J. A. Carr, D. Hotz, J. C. Balda., 2009). Here, the voltage step is done without a transformer and a high voltage

gain is achieved without an extremely high duty ratio but still the circuit becomes more bulky as more number of passive components are used (S K Changchien, T J Liang, J F Chen., 2009).

Though this converter provides a non-pulsating current by using an auto transformer, duty ratio is limited by 0.5 and not suitable for non-linear loads (Wuhua Li, Weichen Li, Xin Xiang., 2014). Here voltage stress of the active switch is reduced thereby the conversion efficiency is improved. This converter requires a multi winding transformer which makes the circuit design complex (Tsorng-Juu Liang, Jian-Hsieng Lee., 2013). This converter avoids extremely narrow turn off period, ripples and switching losses are eliminated by ZVS technique. It uses two coupled inductors which makes the circuit complex (S.V. Araújo, R.P.T. Bascopé., 2010). In this converter no additional magnetic components used, switching losses are minimized by adopting a regenerative snubber circuit. As the circuit uses more switches controlling is complex (S.K. Changchien, T.J Liang., 2010). In this converter high voltage gain is obtained but the circuit has more passive components (Y. Zhao, Y. Deng., 2010). It employees single ended scheme cost is reduced.

Galvanic isolation is needed, but suitable only for low power and frequency applications (J. Bauman and Y.P. Hsieh., 2011).

In this converter no need of extreme duty ratio but if conduction losses or switching losses occurs the efficiency is reduced (J.H. Lee, J.H. Park., 2011). It is possible to generate the non-isolated dc-dc converters but the major drawback is that switching frequency must be maintained constant and the turn ratio of the auto transformer must be unity (Wuhua Li, Weichen .,2012). Some converters operate at very high frequency with fast transient response.

The main switch is fabricated from an integrated power process, the layouts can be changed to vary the parasitic, however design of switch layout is complex, fixed frequency and constant duty ratio must be maintained (T.J. Liang, S.M. Chen and F.L. Tofoli ., 2012) . This converter provides high voltage gain and can be employed for high power applications however the duty ratio is limited to 0.85 (J.M. Burkhart., 2013). In this, the energy of the leakage inductor is recycled to the output load directly, limiting the voltage spike on the main switch. To achieve a high step-up gain, it

has been proposed that the secondary side of the coupled inductor can be used as flyback and forward converters (F.S. Garcia and F.H. Dupont., 2013). In this Converter leakage inductance and parasitic capacitance are neglected only magnetizing inductance considered (Shih-Ming Chen.,2015).

PROPOSED HIGH BOOST DC-DC CONVERTER

Figure-1 shows the circuit diagram of proposed coupled inductor based DC-DC converter .The proposed converter is simply operated by a single switch without zero switching network and complex control. Only the operating principles in the continuous conduction mode (CCM) are discussed in this section. Because parasitic resistance and the capacitance of the active switch and leakage inductance are neglected, the transient states in the operating principle will not be discussed here. The following assumptions are made for the analysis. The converter consists of a power switch, diodes and capacitors. The diodes D1 is turned on when switch S is turned- off, then the voltage across the switch is clamped at a low voltage level ,and the energy stored in the leakage

inductance is recycled into C1 .Since switch S has a low voltage rating and low conducting resistance r_{ds} ,the proposed converter has high efficiency.

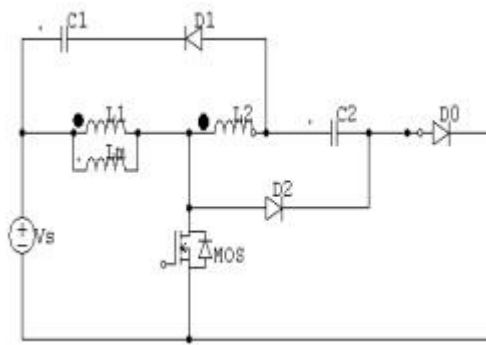

Figure-1. Circuit diagram of proposed converter.

To simplify the circuit analysis, the following conditions are assumed:

1. Capacitors C1, C2, C3 and Co is large enough that the VC1, VC2, and V0 are constant values in one switching period.
2. All semiconductor components are ideal.
3. The magnetizing inductance has been integrated into the Primary winding N1 of coupled inductor.
4. Turns ratio of the coupled inductor $n=N2/N1$.

Mode of operation :

Figure-2 shows the typical waveforms under CCM operation in the one switching period. The operating principle of CCM mode is divided two modes during each switching period. The operating mode is described as follows:

(a) Mode 1 [t0-t1] :

At $t=t_0$, the switch S is turned on, diode D2 is turned on and D1 is turned off. Figure-3.(a) shows the equivalent circuit of the proposed converter in this mode. Meanwhile, the energy from input source Vs is also being stored in magnetizing inductor Lm. During this mode, switched capacitor C2 receives energy from the input source and coupled inductor L2. Because the charging current from input source VS flows to switched capacitor C2 through diode D2 in series with the secondary winding N2 of coupled inductor, the voltage on switched capacitor VC2 is equal to $\left(\frac{D}{1-D}\right)Vs$. This mode ends when switch S1 is turned off at $t = t_1$.

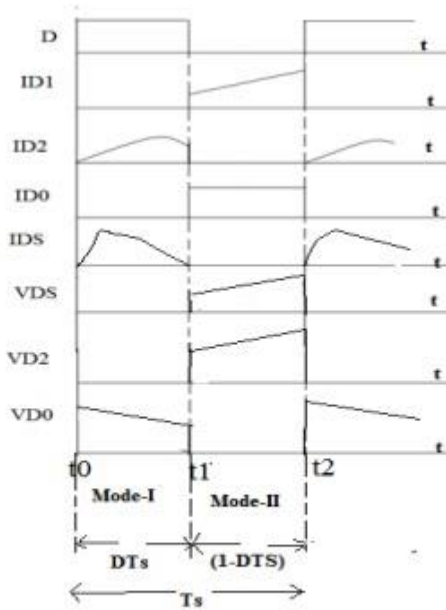
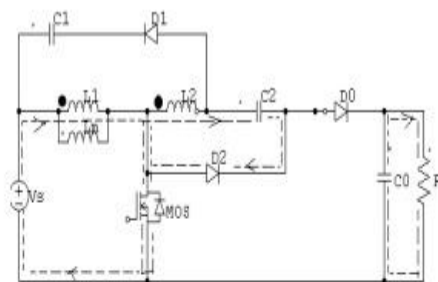
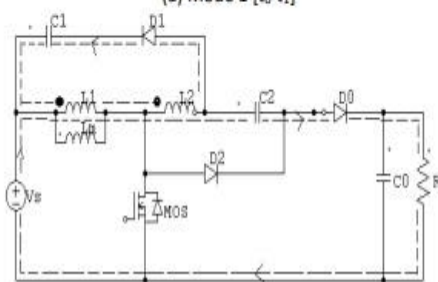

Figure-2. Waveforms of proposed converter.



(a) Mode 1 [t₀-t₁]



(b) Mode 2 [t₁-t₂]

(b) Mode 2 [t₁-t₂]

The energy is being released in this mode. Active switch S and diode D2 are turned off, but diode D1 is conducting. During this mode, energy is being released

through the series-connected path that consists of input source Vs, magnetizing inductor Lm, switched capacitor C2, secondary winding N2, and load R. The energy of secondary winding N2 is coupled from magnetizing inductor Lm at the primary side of the coupled inductor. The energy is released through the current path shown in Figure-3(b). This mode ends when switch S1 is turned on at the beginning of the next switching period.

Analysis of the proposed converter :

When the switch (Q) is turned on , the voltage across the magnetizing inductor (Lm) and V_{L1} are written as

$$V_{L1} = V_{Lm} = V_s \tag{1}$$

$$V_{L2} = nV_{Lm} = nV_s \tag{2}$$

By using voltage-second balance principle on L₁ and L₂ of the coupled inductor, the following Equations are written as

$$\int_0^{DT} V_s dt + \int_{DT}^T V_L dt = 0 \tag{3}$$

$$V_{L1} = -\frac{D}{1-D} V_s \tag{4}$$

$$V_{I2} = -\frac{Dn}{1-D}V_s$$

When the switch (Q) is turned off, the voltage across the inductor V_{I1} and V_{I2} are written as

$$V_{I1} = -V_{c2} \tag{5}$$

$$V_{I2} = V_s(1-D) - V_0(1-D) + DV_s(n+1)/(1-D) \tag{6}$$

By using voltage-second balance principle on L_1 and L_2 of the coupled inductor, the following Equations are written as

$$\int_0^T nV_s dt + \int_0^T V_{I2} dt = 0$$

From equation (6) and (7), V_0 is derived as

$$V_0 = \frac{(2nD+1)}{1-D}V_s$$

As a result, the voltage gain of the step-up converter can be represented as

$$G_v = \frac{(2nD+1)}{1-D}$$

Equation (9) indicates that the proposed converter accomplishes a high voltage gain by using switched Capacitor. Figure-4. Plots the ideal voltage gain

against the duty ratio, under various turns ratios of the coupled inductor under CCM operation.

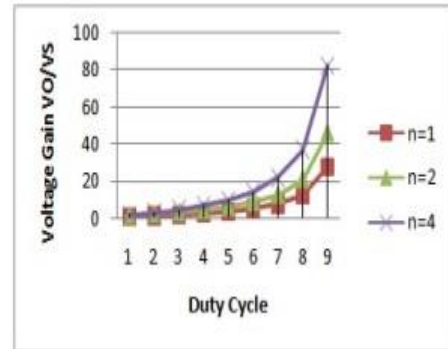

Figure-4. Voltage gain against duty ratio under various turns ratio of coupled inductor.

According to (6) and (7), the voltage stress on the switch is

$$V_{DS} = V_{c1} + V_s$$

$$\tag{10}$$

The output voltage will be the sum of input source V_s , the voltage on switched capacitor C_2 , and the primary and secondary voltages of the coupled inductor, where the respective voltages are illustrated in Figure-3.

Table-1. Performance comparison.

Gain Equation	Voltage Gain	Number of switches	Number of diodes
$V_o / V_S = \frac{(2 + nD)}{1 - D}$ [7]	9.42	1	3
$V_o / V_S = n \frac{(2 - D)}{1 - D}$ [9]	7.7	2	5
$V_o / V_S = \frac{(2 + n - D)}{1 - D}$ [22]	9.57	1	2
$V_o / V_S = \frac{(1 + n)(2 - D) + 1}{1 - D}$ [20]	11.57	2	3
$V_o / V_S = \frac{(2nD + 1)}{1 - D}$ [PC]	10.28	1	3

Table-1 shows the performance comparison under CCM operation mode between the proposed converter, existing boost converter [7], [9], [20] and [23] with consideri paprameters of $n=2$ and $D=0.65$. The proposed converter have high voltage with one switch and low turns ratio.

DESIGN SPECIFICATION OF THE PROPOSED CONVERTER

A proposed converter had the following specifications:

1. Input DC voltage = 12V
2. Output DC Voltage = 120V
3. Switching Frequency = 50KHZ

4. Output power = 200W

5. Duty cycle = 65%

The on state resistance of the power switch and the primary winding of coupled inductor result much conduction loss for the low input power source of the proposed converter. Therefore, the maximum operating duty ratio is selected as a reasonable duty ratio for the high current issue in this design. The maximum duty ratio is selected nearly 0.65. Based on above circuit specifications, the circuit design consideration can be described as below.

Designing of coupled inductor:

Here coupled inductor is modeled as an ideal transformer, the magnetizing inductor (L_m) and a leakage inductor (L_k). Here the effect of leakage inductance is neglected. The turns ratio (n) of this ideal transformer is defined as

$$n = \frac{N1}{N2} \tag{11}$$

Using above formula, “ n ” found to be 2, so chosen value of inductor in the following equations

$$L_2 = \frac{nD(2nD + 1)R}{2f(1 - D)}$$

$$\frac{L_2}{L_1} = \frac{N_2^2}{N_1^2}$$

From equation (11), (12) and (13), select the values $L1=2.52mH$, $L2=10mH$. Designing of capacitors When Capacitor $C1$ & $C2$ are charged, the electric charge can be written as follows,

$$C0 = \frac{(V0 - Vs)}{fR(V0 + 2nVs)}$$

Select the value of capacitor $C0=171.99nF$.

Power switch selection

To analyze the current stress easily, the current of the input inductors is taken as constant. The RMS current of the main switch is given by

$$I_{RMS} = I_0 \sqrt{D \left(\frac{2(1-D)}{1/D} \right)}$$

Accordingly, from above equation for high switching frequency power MOSFET is selected as a switching power device, respectively.

Output diode selection :

The average current of the diode during turnoff condition is given by

$$ID1 = ID2 = ID3 = I = I_0 \quad (23)$$

The current through the diodes is equal to output current I_0 .

SIMULATION DIAGRAM AND RESULTS

SIMULATION CIRCUIT:

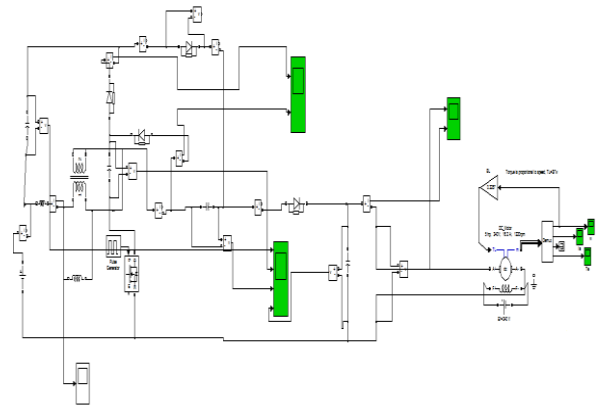

Figure-5. Simulation Diagram

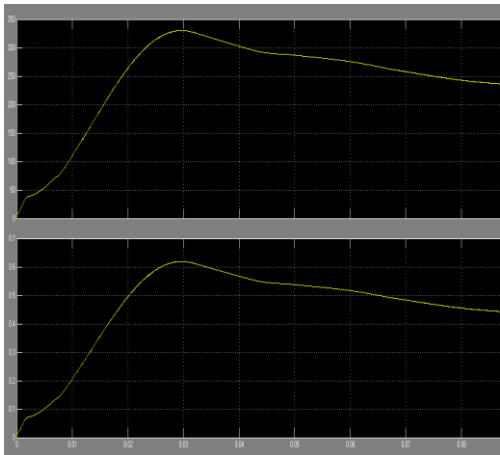

Figure-6: Load Voltage & Current

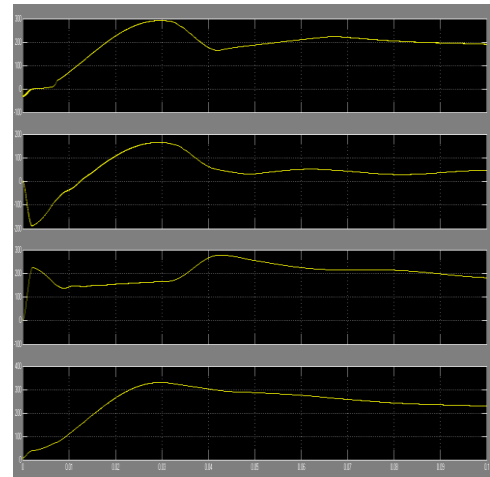

Figure:7. Capacitors C1,C2,C3,C0 Voltages.

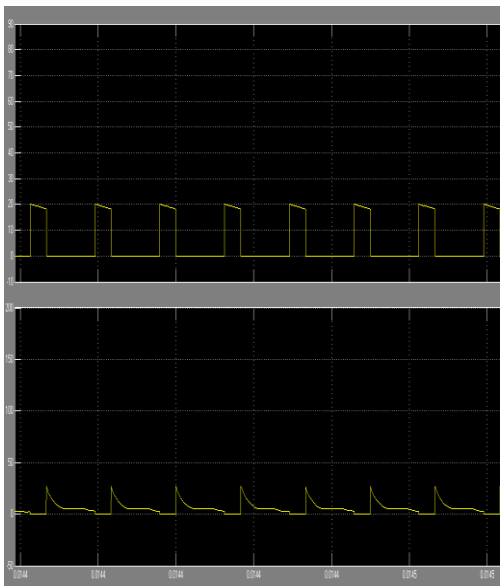

Figure-7: Diodes D1 & D2 Currents

CONCLUSION:

The proposed coupled-inductor based DC-DC converter is a simple dc-dc step-up converter with a high voltage conversion ratio inherent in this converter. By adopting coupled-inductor and switched-capacitor techniques, the proposed converter successfully enlarges the voltage conversion ratio without a high turns ratio of the coupled inductor. The voltage gain is 10 when the turns ratio of the coupled inductor is two. The efficiency of the proposed converter is 97.9%. Moreover, the diodes can be replaced with switches to form a bidirectional switched-coupled inductor converter.

REFERENCES

- [1] Q. Zhao and F. C. Lee. 2003. High-efficiency, high step-up dc–dc converters. *IEEE Trans. Power Electron.* Vol. 18, no. 1, pp. 65–73, January.
- [2] T.F. Wu, Y.S. Lai, J.C. Hung and Y.M. Chen. 2008. Boost Converter with Coupled Inductors and Buck Boost Type of Active Clamp. *IEEE Trans Ind. Electron.* Vol. 55, no. 1, January.
- [3] B. Axelrod, Y. Berkovich and A. Ioinovici. 2008. Switched Capacitor/Switched-Inductor Structures for Getting Transformerless Hybrid DC–DC PWM Converters. *IEEE Trans Circuits and Systems—I: Regular Papers.* Vol. 55, no. 2, March.
- [4] R.J. Wai, C.Y. Lin, C.Y. Lin, R.Y. Duan and Y.R. Chang. 2008. High-Efficiency Power Conversion System for Kilowatt-Level Stand-Alone Generation Unit with Low Input Voltage. *IEEE Trans Ind. Electron.* Vol. 55, no. 10, October.
- [5] J.M. Kwon and B.W. Kwon. 2009. High Step-Up Active-Clamp Converter with Input-Current Doubler and Output-Voltage Doubler for Fuel Cell Power Systems. *IEEE Trans. Power Electron.* Vol. 24, no. 1, January.
- [6] J. A. Carr, D. Hotz, J. C. Balda, A. Mantooth, A. Ong and A. Agarwal. 2009. Assessing the Impact of SiC MOSFETs on Converter Interfaces for Distributed Energy Resources. *IEEE Trans. Power Electron.* Vol. 24, no. 1, January.
- [7] S K Changchien, T J Liang, J F Chen and L S Yang. 2009. Step –Up DC-DC Converter by coupled inductor and Voltage Lift Technique”*IET Power Electronics*, December.
- [8] wuhua Li, Weichen Li, Xin Xiang, Yihua Hu. and Xiangning He. 2014. High Step Up Interleaved Converter with Built-In Transformer Voltage Multiplier Cells for Sustainable Energy Applications. *IEEE Trans on Power Electronics.* Vol. 29, no. 6, June.
- [9] Tsorng-Juu Liang, Jian-Hsieng Lee, Shih-Ming Chen, Jiann-Fuh Chen and Lung-Sheng Yang. 2013. Novel Isolated High Step-Up DC-DC Converter with Voltage Lift. *IEEE Transaction on Industrial Electronics*, Vol. 60.No.4 , April.
- [10] S.V. Araújo, R.P.T. Bascope and G.V.T. Bascope. 2010. Highly Efficient High Step-Up Converter for

Fuel-Cell Power Processing Based on Three-State Commutation Cell. IEEE Trans Ind. Electron. Vol. 57, no. 6, June.

[11] S.K. Changchien, T.J Liang, J.F. Chen and L.S. Yang. 2010. Novel High Step-Up DC–DC Converter for Fuel Cell Energy Conversion System. IEEE Trans Ind. Electron. Vol. 57, no. 6, June.

[12] Y. Zhao, Y. Deng and Xiangning. 2010. Interleaved Converter with Voltage Multiplier Cell for High StepUp and High-Efficiency Conversion. IEEE Trans. Power Electron., Vol. 25, no. 9, September.

[13]J. Bauman and M. Kazerani. 2011. A Novel Capacitor-Switched Regenerative Snubber for DC/DC Boost Converters. IEEE Trans Ind. Electron. Vol. 58, no. 2, February.

[14] Y.P. Hsieh, J. F. Chen, T. J. Liang and L. S. Yang. 2011. Novel High Step-Up DC–DC Converter with Coupled-Inductor and Switched-Capacitor Techniques for a Sustainable Energy System. IEEE Trans. Power Electron. Vol. 26, no. 12, December.

[15]J.H. Lee, J.H. Park and J. H. Jeon. 2011. SeriesConnected Forward–Flyback Converter for High Step-Up

Power Conversion. IEEE Trans. Power Electron.Vvol. 26, no. 12, December.

Authors Details:

AJAY KUMAR



Received B.Tech degree from BANDARI SRINIVAS INSTITUTE OF TECHNOLOGY , GOLAPALLY , CHEVELLA, RANGAREDDY, Telangana in 2013 and currently pursuing M.Tech in Electrical power electronics at SSJ ENGINEERING COLLEGE, VATTINAGULA PALLY, Telangana.

K. SURESH KUMAR



Obtained his b.tech degree from CVR engineering college , Hyderabad in 2005, M.E from ANNA UNIVERSITY , TAMILNADU, IN 2009. Pursuing Ph.d in Hyderabad. He worked as associate professor at SSJ ENGINEERING COLLEGE, HYDERABAD. He is having 7 years teaching experience. Area of interest is in power electronics,(VLSI).



S . JAGADEESH



Obtained his B.tech degree from Sri Krishnadevaraya university, ananthapur in 1995, M.Tech from JNTU Hyderabad in 2006, pursuing Ph.D in JNTU Hyderabad. He worked as Asst. Prof. and Associate Professor at SSJ Engineering college Hyderabad. He is having 15 years teaching experience.