

---

# MPPT Control Strategies for Solar Energy Harvesting Using smc Approach

---

Chavan Vishakha S.  
PG (Control System) Department  
M. B. E. Society's College Of Engineering Ambajogai, India  
Email:-vishakha.chavan8181@Gmail.com

**Abstract-** This paper presents a new maximum power point tracking facility for a standalone photovoltaic (PV) system. The unique combination of SMC controller with Voltage Reference Estimator and Partial Shadowing Technique are occur. The goal of this work is to maximize power extraction from the photovoltaic generator (PVG). Sliding mode controller (SMC) drives the Boost Converter connected between the PVG and Load. The system is modelled and tested under MATLAB/SIMULINK environment. In simulation, The sliding mode controller offers fast and accurate convergence to the maximum power operating Point that performs the well-known perturbation and observation.

The fast dynamics and all range stability are attained by a sliding mode controller and the high tracking efficiency by a maximum power point algorithm with fine step.

**Keywords-** PV System, Sliding Mode Controller (SMC), MPPT. Partial Shadowing, Boost Converter.

Sankeswari S. S.  
PG(Control System) Department  
M. B. E. Society's College Of Engineering Ambajogai, India  
Email:-sankeswari@Gmail.com

## I. INTRODUCTION

The economic and industrial development in addition to the interest in environmental issues have greatly increased the need of new and clean renewable energy sources. The fluctuations of rising oil prices and increasingly worrying degree of pollution contrasted with the new provisions of sustainable development make alternative and renewable energy sources more attractive Economic incentives and huge advancement in electronic technology promote the use of photovoltaic systems. These systems present a simple and convenient solution from an economic point of view. They have the merits of direct electrical energy conversion, utilization in rural areas, absence of noise or moving parts,

low operation cost, and flexibility in size [1-2]. The use of a converter on these photovoltaic systems is even more compelling as it increases their efficiency and reduces their costs. This work analyses the control of a stand-alone PV system. The success of a PV application depends on weather conditions where the power electronic devices help to increase the efficiency of the PV generator (PVG). Extracting maximum power from the PVG is a challenge. Maximum power point tracking (MPPT) controller accuracy is a key control in the device operation for successful PV applications. In general, a PV system is typically built around the following main components.

- (1) PVG that converts solar energy into electric energy.
- (2) DC-DC converter that manipulates produced DC voltage by the PVG to feed a load voltage demand.
- (3) Digital controller that drives the converter commutations accordingly to a MPPT capability.
- (4) A load

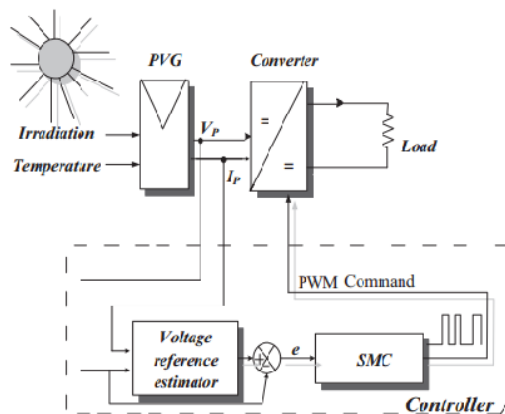

Fig:1. Synoptic diagram of PVG system

Presently, the most commonly used algorithms are perturb and observe (P&O)[2], incremental conductance (Inc.Cond)[3], fractional open-circuit voltage and short circuit current [3], fuzzy logic controller (FLC) approaches [4], and Adaptive neuro fuzzy inference system, etc. [5]. P&O algorithm is widely used in standalone systems for its simple implementation [2], it can easily lead to erroneous judgment and oscillation around the maximum power point (MPP) which results in power loss. On the other hand, when compared to P & O method, SMC technique can accurately track the MPP, with less steady-state oscillations and faster response especially under rapidly varying environmental conditions, thus increasing the tracking efficiency [1]. In general, the MPPT control is challenging because the conditions that determine the amount of sun energy into the PVG may change at any time. As such, the PV system can be considered as non-linear complex. The sliding mode controller has recently attracted considerable attention from researchers due to several advantages [6,7], the main advantage of the SMC is its implementation simplicity, robustness, and great performance in different fields such as robotics [8] and motor control [9]. This work

interest focused on the use of SMC in the photovoltaic fields by maximizing the power generated from the PV panels while maintaining the system stability. This thesis presents a new design of stable SMC for PV system control. The proposed control methodology is built into two steps in order to control a PV system. The first step consists of an estimator synthesis of  $V_{ref}$ . This last corresponds to the (MPP) working voltage  $V_{ref} = V_{MPP}$ . The second is to perform the system tracking based on the developed SMC regulator for a boost converter and according to the estimated voltage value.

In previous work [5], the ( $V_{ref}$ ) value can be provided only after the drawing of panel characteristics; however, this value will be valid only for a short period, so any change in weather will cause a change in its characteristics and as a result a change in the value of  $V_{MPP}$ . This method, as consequence, is valid only after determination of the right value of  $V_{MPP}$  [10,11]. The main objective in this work is to construct an MPP voltage-reference estimator that meets the MPP. The estimator is designed specifically in order to compute on-line the optimal voltage value  $V_{MPP}$ .

This thesis shows the proposed SMC uses the error between the measured voltage of the PV module and the voltage generated by the voltage reference estimator to adjust continuously the duty cycle (D) of the DC-DC Boost converter in order to eliminate this error. The reference voltage value is generated online with no need to know the actual irradiation. The PV system topology proposed is shown in Fig. 1. the SMC algorithm directly generates the PWM signal. It has the benefit of avoid the use of the PWM commutation signal (Saw signal). The SMC overcomes the limitations with other algorithms such as P & O [12] and Inc [13] which generates a duty cycle control value comparable to saw signal to uphold a PWM IGBT drive signal. The performance of a photovoltaic module is highly affected by the partial shaded condition [14]. The PVG under partial shading makes maximum power point (MPP) tracking difficult; generally, there will exist multiple local MPPs, and their values will change as rapidly as the illumination [15]. Finding a solution to this problem ensures PVG power reliability and strengthens its economic rationale. Installers have an interest in resolving this issue. Many installers carefully design installations to avoid structural shading [16]. Installers could make a relatively effective strategy in order to avoid partial structural shading by carrying out a precise study of the proposed photovoltaic (PV) site of installation. The loss of energy caused by the partial shading (PS) is difficult to predict because it depends on several variables including internal module-interconnections [17]. Researchers and engineers developed an electronic solution to this problem by identifying and harvesting the maximum power of each panel individually using power optimizer technology [18], however, this method increases the cost of the installation. In addition, most MPPT are not able to get the maximum power point under these conditions. In this thesis a unique combination of a partial shading detector, voltage reference estimator and a sliding mode controller. This method is suitable to guarantee MPPT even under partial shadowed conditions. The originality of the method is in the usage of the voltage reference estimator and the partial shadow detection unit; this method supervises the MPPT voltage value continuously and is able to detect when the MPPT voltage is perturbed by the presence of PS. Once the PS is detected, an adjustment of the voltage value is triggered; the adjustment considers the voltage reference estimator output as an initial condition. The global MPP is calculated and the MPPT operation point is changed accordingly using a robust SMC. The important advantage of this method is its simplicity, since the partial

shadow detection unit can be combined with any MPPT algorithm such as the sliding mode controller. This method operates successfully even though a partial shadow arises. The comparison of sliding mode controller and Perturbation and observation method is taken to know the best performance of SMC. The effectiveness of the proposed method is confirmed by the obtained result.

This paper is structured as follows: A brief description of the of the considered PV model is presented in Section 2, while Section 3 deals with the explanation of the entire proposed MPPT method; a detailed analysis of the voltage reference generator and a sliding mode controller method is described. Section 4 is dedicated to the partial shadowing (PS) study and the description of the PS-SMC algorithm. Simulation results are carried out in Section 5. Finally, some conclusions and future work are described in Section 6.

## 2. PHOTOVOLTAIC SYSTEM MODELLING

PV cells have P-N Junction similar to diode. It generates the electrical power by using photons. It has the capacity to absorb solar irradiation and mobilize the photon to electron until it converges .when a load is connector to PV cell the charge flows through it as a direct as a direct current until the irradiation gets stops.

The cells are connected in series and/or parallel to achieve the regarding current and voltage. If the cells are connected in series then it produces the large output voltages whereas if the connection is in parallel it produces large output currents. The modelling of the solar cell is defined by voltage current regulation of PV system as follows,

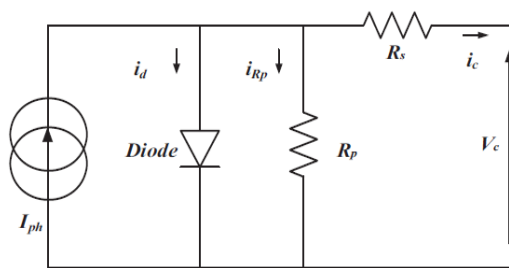

Fig.2 Equivalent circuit of PV cell

The Node law gives,

$$I = I_{ph} - I_d - I_{sh} \quad (1)$$

$$I_{ph} = \frac{G}{G_{ref}} (I_{rs-ref} + K_{sct}(T_c - T_{c-ref})) \quad (2)$$

$$I_d = I_{rs} \left[ \exp\left(\frac{V_c + I_c R_s}{a}\right) - 1 \right] \quad (3)$$

$$I_{sh} = \frac{V_c + R_s I_c}{R_p} \quad (4)$$

Finally, the cell current I can be given by:

$$I = I_{ph} - \left[ \exp\left(\frac{V_c + I_c R_s}{a}\right) - 1 \right] - \frac{V_c + R_s I_c}{R_p} \quad (5)$$

Where,

Id- Current through diode(A)

Irs, Iph- Reverse diode saturation current and phase current (A)

Ns,Np- number of PV modules connected in series and parallel.

K- Boltzmann's Constant

$$= 1.381 * 10^{-23} (J/K).$$

Tc,Tc-ref - cell temperature and reference temperature (°C).

A- Ideality factor = 1.3

q = electron charge =  $1.602 * 10^{-19} (C)$ .

G,Gref – irradiation and irradiation at STC (1000)(W/m<sup>2</sup>).

Vc, Ic- output voltage and current.

Ksct- Short circuit current temperature

$$= 2.2 * 10^{-3}.$$

The modelling of a PVG as given in Fig. 2 depends on NS and Np that are the total numbers of series and parallel modules respectively.

$$I_p = N_p I_c$$

$$V_p = N_s n_s V_c$$

Finally the PVG current (Ip) can be given by,

$$I_p = N_p I_{ph} - N_p I_{rs} \left( \exp \frac{q}{\alpha K_T} \left( \frac{V_p}{n_s N_s} + \frac{R_s I_p}{N_p} \right) - 1 \right) - \frac{N_p}{R_p} \left( \frac{V_p}{n_p N_p} + \frac{R_s I_p}{N_p} \right) \quad (6)$$

The terms containing Rs and Rp parameters could be eliminated by simplification assumption  $R_p \gg R_s$ . Here the ideal model case is considered such as  $R_s = 0$  and  $R_p = \infty$

$$I_p = N_p I_{ph} - N_p I_{rs} \left( \exp \frac{q}{n_s K T_c} \left( \frac{V_p}{n_s N_s} \right) - 1 \right) \quad (7)$$

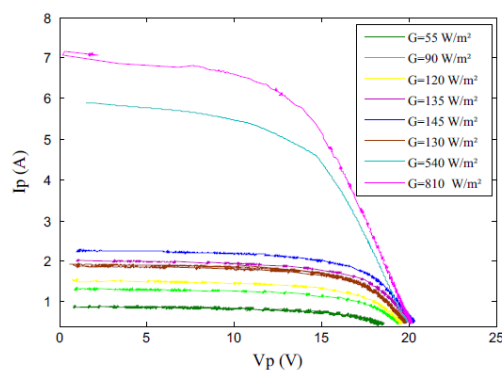

Fig: 3. I-V characteristics for different irradiances.

In order to increase the power, four modules are connected in parallel to form the PV panel that will be used in this paper. The extreme I–V nonlinear characteristics are shown in Fig. 3. These real characteristics are logged and plotted for different radiation values and an almost constant temperature.

### 3. Power Boost Converter

DC-DC converters are electronic devices used whenever there is a need to bring up or down a DC electrical voltage level to another. In this thesis, the Boost converter will hold the PVG maximum working point through a regulator called MPPT. Hence, the current PVG system efficiency is boosted. In order to step up the voltage, the operation switches an IGBT shown in Fig.4 at a high commutation frequency with output voltage control by varying the switching duty cycle (D)[21,22]. Fig.4 shows the circuit diagram of the converter and the load. The converter is assumed to operate in a continuous conduction mode with two states based on the status of the switch.

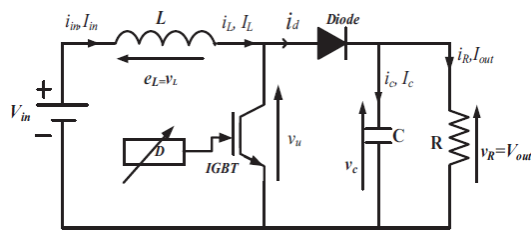

Fig:4. Circuit diagram of the Boost converter.

Mode1: In the first state, the IGBT On, diode is Off. During this phase, the inductor is directly connected to the PVG and the diode is blocked. The load is then disconnected from the supply. The current in the inductance increases by storing magnetic energy. Considering that the variable state is:

$$x = \begin{pmatrix} i_L \\ v_R \end{pmatrix} = \begin{pmatrix} x_1 \\ x_2 \end{pmatrix}$$

$$\begin{cases} \dot{x} = A \cdot x + B \cdot u \\ y = E \cdot x + F \cdot u \end{cases} \quad (8)$$

With  $E = [0 \ 1]$ ,  $F = 0$ ,  $u = v_{in}$ ,  $y = v_{out}$

The Kirchhoff's laws on the converter circuit yields:

$$\begin{cases} v_{in} = v_L = L \frac{di_L}{dt} = L \dot{x}_1 \\ v_{out} = v_C = v_R = x_2 \end{cases} \rightarrow \begin{cases} \dot{x}_1 = \frac{1}{L} v_{in} \\ i_C = -i_R \leftrightarrow \dot{x}_2 = -\frac{1}{R_C} x_2 \end{cases} \quad (9)$$

With,

$$A_1 = \begin{bmatrix} 0 & 0 \\ 0 & -\frac{1}{R_c} \end{bmatrix}; B_1 = \begin{bmatrix} \frac{1}{L} \\ 0 \end{bmatrix}$$

Mode2: IGBT is Off; diode is ON: The inductor emf is added to that of the PVG. The current flows through the inductor, the capacitor, the diode and the load. The result is an energy transfer stored in the inductor to the capacitor.

$$\begin{cases} v_{in} = v_L + v_{out} \\ i_c = i_L - i_R \end{cases} \rightarrow \begin{cases} \dot{x}_1 = -\frac{1}{L}x_2 + \frac{1}{L}v_{in} \\ \dot{x}_2 = \frac{1}{C}x_1 - \frac{1}{RC}x_2 \end{cases} \quad (10)$$

With,

$$A_2 = \begin{bmatrix} 0 & -\frac{1}{L} \\ \frac{1}{C} & -\frac{1}{RC} \end{bmatrix}; B_2 = \begin{bmatrix} \frac{1}{L} \\ 0 \end{bmatrix}$$

As a result,

$$\begin{cases} A = DA_1 + (1 - D)A_2 \\ B = DB_1 + (1 - D)B_2 \end{cases} \quad (11)$$

$$A = \begin{bmatrix} 0 & \frac{D-1}{L} \\ \frac{1-D}{C} & -\frac{1}{RC} \end{bmatrix}; B = \begin{bmatrix} \frac{1}{L} \\ 0 \end{bmatrix}$$

The steady-state solution of the converter in continuous conducting mode is therefore [23]

$$G = \frac{y}{u} = \frac{V_{out}}{V_{in}} = E \cdot (-A)^{-1}B + F \quad (12)$$

The steady-state solution is equivalent to

$$V_{out} = \frac{1}{1-D}V_{in} \quad (13)$$

Based on the assumption where  $P_{in} = P_{out}$  it can be deduced that

$$R_{pv} = (1 - D)^2 R_{out} \quad (14)$$

Where  $R_{pv}$  is the equivalent resistance connected to the PV panel [24].

### 3. MPPT control

The Maximum Power Point Tracking (MPPT) control is a fundamental phase in order to obtain a good performance in a PVG system. Usually, the principle of this MPPT is



based on adapting or varying the converter duty cycle (D) to finally bring the PVG working in its MPP.

### 3.1 Sliding mode controller

The SMC-MPPT algorithm is divided into two steps. The first is to estimate the actual reference voltage (VMPP) value at which the system will reach its maximum power. The second is the SMC PVG voltage regulation at the VMPP voltage value. These steps lead to a PVG MPP working point.

The main role of this controller is to generate a command using a voltage reference (Vref) in order to force the system to work at the maximum power point (MPP). The main novelty in this method is to define the input of the controller as:  $v_p - v_{mpp}$ . This input can be easily calculated and based on the bijectivity principle between VMPP and PMPP. So if the system will work at the VMPP, the maximum of power will be obtained (PMPP).

### 3.2 VOLTAGE REFERENCE ESTIMATOR

Authors in [25] calculate the voltage VMPP value such as,  $VMPP = K_v * V_{oc}$ , with  $V_{oc}$  is the open circuit, or by directly reading and sending VMPP to the regulator. This last requires basically a direct knowledge of the  $V_{oc}$  or VMPP values. Generally, users of this method draw the PV characteristics and then feed the target values to the MPPT regulator. This method poorly tracks the VMPP input value that actually changes according to the temperature and depends on the irradiation values as shown in Fig.5 shows that for almost constant temperature and different irradiation values, the maximum power (PMPP) is obtained for different voltage values (VMPP). By joining the different MPP obtained for different irradiation values, we can construct the red curve that for a given (PMPP) value indicates the corresponding VMPP. Therefore, this red curve can be used as a MPP voltage reference estimator constructed using a fitting function F with  $V_{MPP} = F(P)$ .

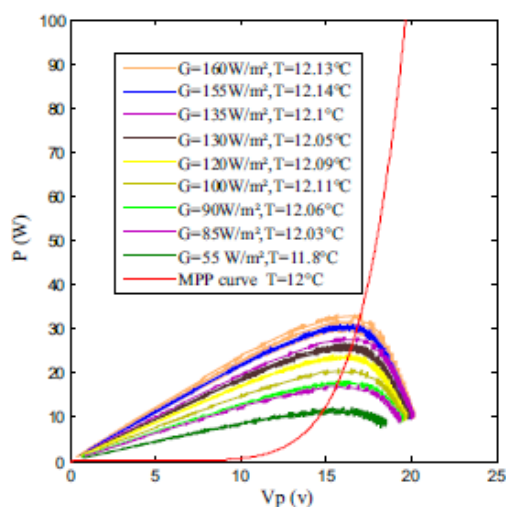

Fig:5. Real P-V characteristics for different irradiances at almost constant temperature.



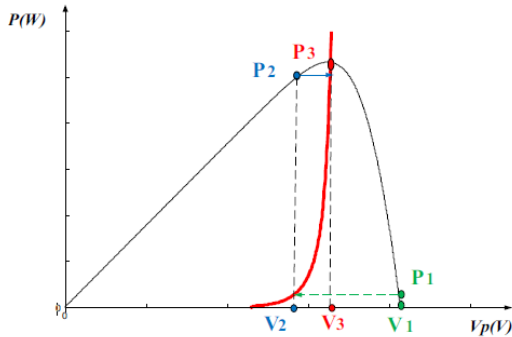

Fig:6. -PV characteristics at fixed temperature value of 25°C

fig.6 explains that for any state, after several iterations (projection), the system will be forced to work with the desired voltage VMPP and hence meets the MPP. For example, assuming that the PV system is working in an operating point P1, after projection using the reference voltage curve, the reference voltage changes from "V1 to "V2 and consequently the operating point of the PV system will change its position to P2. Using the same principle, the P2 will be projected again on the reference curve, and changes its position until the operating point reaches the MPP as shown in Fig.5 where finally P3 = PMPP . As a result, the constructed red curve can be used as a MPP reference voltage estimator. The main and direct advantage of this approach is that we can overcome the usually required solar radiation sensor[26,27]

$$\begin{aligned}
 V_{MPP} &= F(X, Y) \\
 &= p_{00} + p_{10} * X + p_{01} * Y + p_{20} * X^2 + p_{11} * XY + p_{30} * X^3 + p_{21} * X^2 * Y + p_{40} * X^4 + p_{31} * X^3 * Y + p_{50} * X^5 + p_{41} * X^4 * Y
 \end{aligned}
 \tag{15}$$

With,  $X = (P - \text{mean}X)/\text{std}X$  and  
 $Y = (T - \text{mean}Y)/\text{std}Y$

meanX =73.38, stdX = 67.38; meanY = 29.7, stdY = 13.05

$$\begin{array}{lll}
 p_{00} = 15.29 & p_{10} = 0.6488 & p_{01} = -1.09 \\
 p_{20} = -0.5132 & p_{11} = 0.01793 & p_{30} = 0.4582 \\
 p_{21} = -0.01153 & p_{40} = -0.2286 & p_{31} = -0.001497 \\
 p_{50} = 0.04033 & p_{41} = 0.001746 &
 \end{array}$$

Step 2: SMC

After the estimation of VMPP, the implemented SMC is used to drive the regulation element in such a way to reduce the actual voltage error between the acquired PVG voltage and the target VMPP.

$$S = e = V_p - V_{ref} \quad (16)$$

$$u = \frac{1}{2}(1 + \text{sign}(S)) \quad (17)$$

$$u = \begin{cases} 1 & S > 0 \\ 0 & S < 0 \end{cases} \quad (18)$$

Stability demonstration:-

The stability can be analysed based on the Lyapunov theory. A positive definite function  $V$  is defined as

$$V = \frac{1}{2}S^2 > 0 \quad (19)$$

Whose time derivative is:  $V = S \frac{ds}{dt} = S\dot{S}$ .

$$\text{Considering } \begin{cases} S = e = V_p - V_{*MPP} \\ \dot{S} = \dot{e} = \dot{V}P \end{cases}$$

Next, based on the principle of Lyapunov, it is demonstrated that  $S$  reaches the state  $S = 0$ . Therefore the system reaches the desired voltage value VMPP, and thus reaches the point of maximum power.

When  $S > 0$

The switch will be open; this implies that the duty cycle will increase. From the boost converter model Eq. (14) we have,  $R_{pv} = (1 - D)^2 R_{out}$  and using this equation, we can observe that:

– If the duty cycle  $D$  increases, then  $R_{pv}$  decreases, so based on the PV dynamic given by the I–V characteristic shown in Fig. 7, the  $I_p$  will increase and  $V_p$  will decrease equivalently from Eq. (7). It can be deduced that when the voltage ( $V_p$ ) increases/decreases, The current ( $I_p$ ) decreases/increases. So, as a result in this case, this implies  $\dot{V}p < 0$  and  $\dot{S} < 0$

Finally,  $S\dot{S} < 0$ .

When  $S < 0$ , Using the same method.

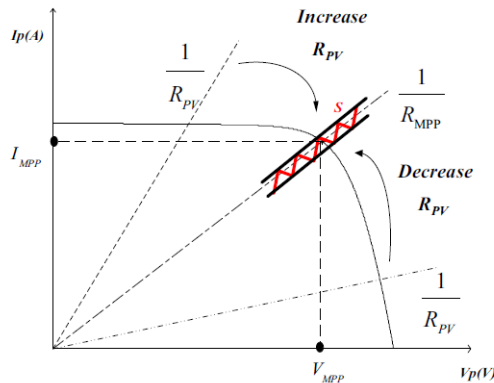

Fig.7-IV characteristics and MPPT process

The switch will be close, this implies that the duty cycle will decrease. If the duty cycle  $D$  decreases, then  $R_{pv} = (1 - D)^2 R_{out}$  increases. Therefore, based on the PV dynamic given by the I–V characteristic shown in Fig. 7, the  $I_p$  will decrease and  $V_p$  increases equivalently from Eq. (7). It can be deduced that, when the voltage ( $V_p$ ) decreases/increases the current ( $I_p$ ) will increase/decrease, so:

If the resistance connected to the PV panel increases then ( $V_p$ ) increases and ( $I_p$ ) decreases, this implies that:

$$\dot{v}_p > 0 \text{ And } \dot{S} > 0$$

$$\text{So } S\dot{S} < 0$$

Finally, using the Lyapunov stability theory it can be concluded that  $S$  reaches the state  $S = 0$ , meaning that the system reaches the desired voltage value  $V_{MPP}$  and hence the converges to the point of maximum power.

#### 4.partial shadowing of photovoltaic arrays (PVG)

A number of series/parallel connected PV modules are used to construct a PVG for a desired voltage and current level as previously shown in Fig.8 The performance of the series connected string of the solar cells is unfortunately affected if all its cells are not equally illuminated (partially shaded) . Fig.8 shows the characteristics of the PVG in cases of shadow presence or no shadow presence.

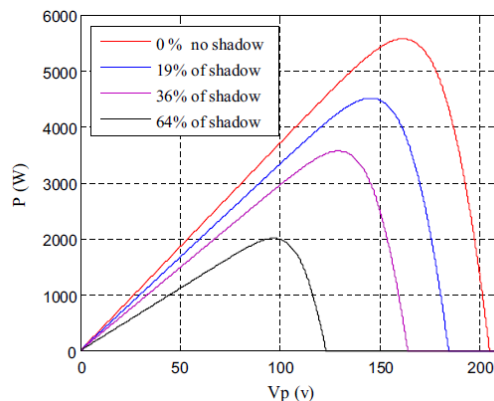

Fig:8.- PV Characteristics under constant irradiation (1000 W/m<sup>2</sup>) and temperature (25 °C) values.

Partial shadow (PS) is a common reason of power loss in a photovoltaic application. This loss of efficiency can occur in many ways. Depending on the object causing the shading, it could only be seasonal, or for a few hours each day, resulting in obviously mysterious fluctuations in the power as shown in Fig.8 . This paper proposes an additional algorithm to be added after the voltage reference estimator and before the SMC controller in order to correctly track the MPP against PS disturbance occurring. This work proposes a system based on a simple partial shadow detection method that will be triggered only when PS is detected; in order to check the presence of a PS, this algorithm makes a test every one second; this is accomplished through the test of the power value. As a result, when the power decreases by 10% the correction action will be triggered. This algorithm is called PS-SMC. The flowchart of the PS-SMC concept is shown in Fig. 9. It is divided in three main parts:

- Generating the optimal voltage VMPP under ordinary conditions(no partial shadowing), using the voltage reference estimator.
- Detection of the partial shadow and search for the new optimal voltage.
- Forcing the system to operate with the optimal voltage using the SMC.

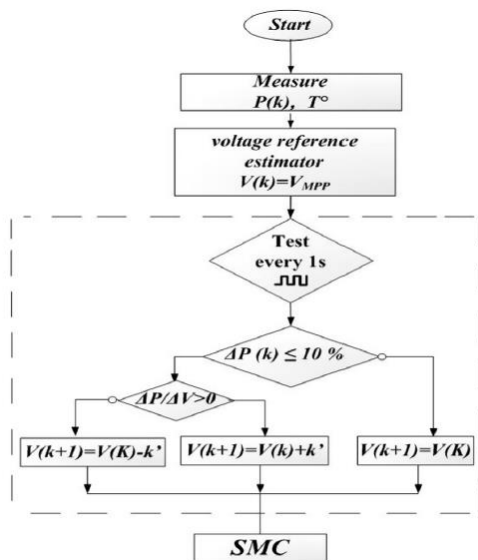

Fig:9.- PS-SMC algorithm flowchart

In this algorithm, temperature and current voltage sensors are required for the voltage reference estimator. The same current and voltage will be later used for the calculation of the power values. First, the voltage reference estimator generates the VMPP. After receiving this last value, this algorithm makes a test every period of one second in order to test the existing shadow by detecting a decrease in the power values. In the case of non-existence of power loss, the current VMPP is directly given as an input for the SMC.

Otherwise if it detects a decrease of 10% in power quantities (if  $DP < 10\%$ ), the search for the new optimal voltage (new MPP) will begin. This algorithm will start the search from the VMMP to the optimal voltage of the PVG under ordinary conditions. This last voltage is generated by the used voltage reference estimator. In order to minimize the  $\Delta p/\Delta v$  ratio value, and starting from the actual VMMP, the voltage is decreased or increased according to the sign of  $\Delta p/\Delta v$  with  $K'$  as a constant of the PS-SMC. Finally, the system operates in the new optimal voltage via the SMC.

## 5. Simulation & Simulation Results

Fig:9 shows the Simulink diagram of PS-SMC

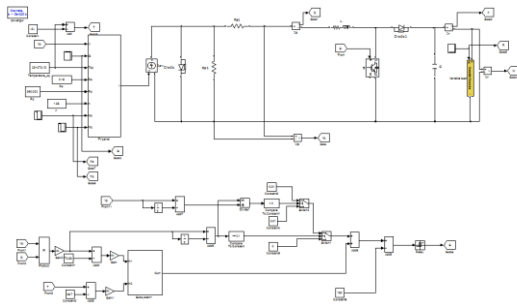

Fig:9. Simulation diagram of proposed system

### 5.1 Simulation results of SMC

The system is tested over a sudden step irradiation and load changes as shown respectively. In output 10,11 this action is used to provoke the controller robustness and the ability to keep the extracting the maximum power within this abrupt variation.

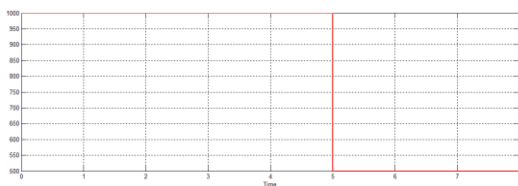

Fig:10. Irradiation abrupt variation



Fig:11. Load abrupt variation

In order to test the PS-SMC robustness against PS the system will suffer 19 % of partial shadowing from 1 to 3 s as shown in Fig12.

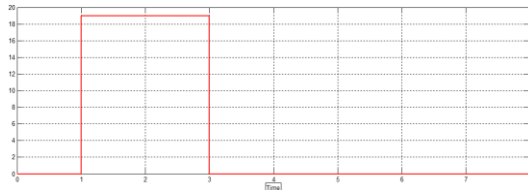

Fig:12. Partial shadow abrupt variation

Fig.13 presents the duty cycle signal delivered by the SMC, which will be used with a reference saw signal to generate a PWM IGBT drive signal. This figure also shows the direct PWM signal generated by the PS-SMC. This has the benefit of avoiding the use of a PWM commutation signal (saw signal). It permits directly constructing the PWM output signal toward the IGBT Gate. In Fig. 13 close up (at second 1 and 5), it is clear that the PWM frequency is affected by the condition changes.

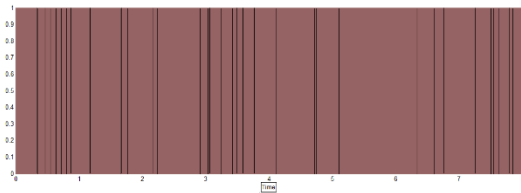

Fig:13. Controller signal output

Fig.14 shows the PVG current, voltage and power respectively. As observed in Fig.14 the PS-SMC algorithm tracks the new MPP yet always generates an oscillating signal around the optimal power value. Fig. 14(b) shows the output of the voltage reference estimator ( $V_{MPP}$ ); when the PV system is under partial shadow, this voltage doesn't correspond to the voltage at the correct MPP. In this case, the PS-SMC acts in order to adequately modify the MPP reference voltage using the algorithm presented in Fig: 9. It is clear that in the magnified portion of second 2 there is a small perturbation. This perturbation is caused by the PS-SMC test (every second in case of shadow detection) to verify that there is still a partial shadow. At second 5, the irradiation changes, the MPP also changes its position, and so the controllers act in order to track the new MPP.

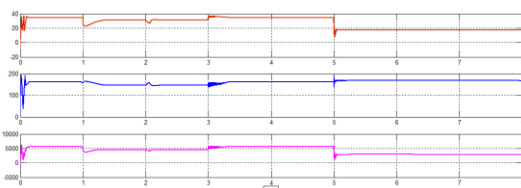

Fig:14. PVG current, voltage and power behaviour

Fig.15 show the load voltage and current. The SMC controller presents less oscillations and faster tracking in its response. The algorithm based on a sliding mode control is a robust and efficient algorithm. Indeed, this algorithm works at the optimum point without oscillations. Furthermore, it is characterized by a good behaviour in transient state.

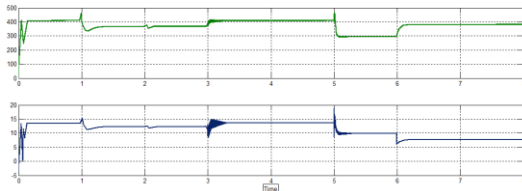

Fig:15. PVG power and Load feeding voltage

This work is focusing on SMC as an MPPT. The main purpose of this thesis is to add a voltage reference estimator that generates the VMPP in ordinary conditions and also add a PS algorithm that detects shadow and generates the adequate voltage value. In order to gain time, The PS algorithm starts the research of the new VMPP from the last value given by the voltage reference estimator. Later, the adequate voltage will be considered as an input for the SMC controller that guarantees the system maximum efficiency and stability. Simulations were performed while rapidly changing shading, load and irradiation disturbances were applied, and the obtained results show that both systems using different controllers present a good maximum power tracking. However, the PS-SMC controllers present lesser oscillations, faster tracking in response and more stability. Moreover, the PS-SMC algorithm has been proved to be effective and sensitive to existing shading.

## 6. CONCLUSION

A PVG system feeding a passive load type through a Boost converter is studied through simulation tests and practical implementation. To improve the system efficiency and performance, a MPPT DC-DC converter driven is synthesized based on the sliding mode theory. The stability of the proposed SMC-MPPT system is verified using the Lyapunov theory. To perform an accurate and rapid SMC-MPP tracker, a simple and reliable estimator was constructed using only temperature and power sensors. This estimator generates the VMPP according to simultaneous temperature and irradiation variations. It is dressed in an analytical form to be easy to implement. The proposed MPPT algorithm ensures robustness and high tracking performance. To compensate and overcome the PVG shadowing effects and drawbacks, a new algorithm is proposed PS-SMC. Many tests were performed in an extensive simulation work to verify the robustness and the high performance of the proposed PS-SMC algorithm against partial shadow, load profile, and irradiation variations. Obtained results were presented and discussed. A practical implementation work was performed yielding a real prototype for implementation of the used algorithm. Experimental results and practical setup are described and discussed for the PVG system with a SMC-MPPT.



This thesis summarizes the main algorithms driving an entire PVG system obtained after long and extensive work, which dealt with theoretical and experimental efforts. Acquired results are very encouraging and suggest perspective experimental and theoretical studies for boosting PVG system performances.

This paper summarizes the main algorithms driving an entire PVG system obtained after long and extensive work, which dealt with theoretical and experimental efforts. Acquired results are very encouraging and suggest perspective experimental and theoretical studies for boosting PVG system performances. Moreover, this work can be extended to consider dynamic load types.

## 7. References

- [1] MaissaF, Oscar B, Lassaad S. A new maximum power point method based on a sliding mode approach for solar energy harvesting. Universidad del Pas Vasco, EUI, Nieves Cano 12, 01006 Vitoria, Spain
- [2] Zakzouk NE, Abdelsalam AKA, Helal A, Williams BW. Modified variable-step incremental conductance maximum power point tracking technique for photovoltaic systems. 39th Annual conference of the IEEE industrial electronics society. IECON; 2013. p. 17418.
- [3] Hadji S, Gaubert J, Krim F. Maximum Power Point Tracking (MPPT) for photovoltaic systems using open circuit voltage and short circuit current. In: IntConfSyst Control (ICSC).
- [4] El Khateb A, Rahim NA, Slvarj J, Uddin MN. Fuzzy logic controller based SEPIC converter for maximum power point tracking. IEEE Trans IndAppl 2014;50:234958.
- [5] Farhat M, Barambones O, Sbita L. Efficiency optimization of a DSP-based standalone PV system using a stable single input fuzzy logic controller. Renew Sustain Energy Rev 2015;49:90720.
- [6] Alqahtani A, Utkinin V. Self-optimization of photovoltaic system power generation based on sliding mode control. In: Proceedings of IECON12. p. 346874.
- [7] Levron Y, Shmilovitz D. Maximum power point tracking employing sliding mode control. IEEE Trans Circuits Syst 2013;60:72431.
- [8] Cid-Pastor A. Synthesis of loss-free resistors based on sliding-mode control and its applications in power processing. Control EngPract 2013;21:68999.
- [9] Oscar LL, Maria TP, Manel GA. New MPPT method for low-power solar energy harvesting. IEEE Trans Industr Electron 2010;57:312938.
- [10] Elgendy M, Zahawi AB, Atkinson DJ. Comparison of directly connected and constant voltage controlled photovoltaic pumping systems. IEEE TransSustain Energy 2010;1:18492.
- [11] Xianwen G, Shaowu L, Rongfen G. Maximum power point tracking control strategies with variable weather parameters for photovoltaic generation systems. Sol Energy 2013;93:35767.
- [12] Jubaer A, Zainal S. An improved perturb and observe (P & O) maximum power point tracking (MPPT) algorithm for higher efficiency. Appl Energy 2015;150:97108.

- [13] Saravanan S, Ramesh Babu N. Maximum power point tracking algorithms for photovoltaic system a review. *Renew Sustain Energy Rev* 2016;5:192204.
- [14] Mohammedi A, Mezzai N, Rekioua D, Rekioua T. Impact of shadow on the performances of a domestic photovoltaic pumping system incorporating an MPPT control: a case study in Bejaia, North Algeria. *Energy Convers Manage* 2014;84:209.
- [15] Alsayid AB, Alsadi SY, Jallad JS, Dradi MH. Partial shading of PV system simulation with experimental results. *Smart Grid Renewable Energy* 2013;4:42935.
- [16] Sun Y, Chen S, Xie L, Hong R, Shen H. Investigating the impact of shading effect on the characteristics of a large-scale grid-connected PV power plant in Northwest China. *Int J Photoenergy* 2014. <http://dx.doi.org/10.1155/2014/763106>. 9 pages 763106.
- [17] Gao L, Dougal RA, Liu S, Iotova AP. Parallel-connected solar PV system to address, partial and rapidly fluctuating shadow conditions. *IEEE Trans Indust Electron* 2009;56:154856.
- [18] Anusuya C, Venkatasubramanian S. Design and implementation of solar power optimizer for DC distribution system using dual active bridge. *Int J Adv Res Elect Electron Instrument Eng* 2014;3:16873.
- [19] Farhat M, Sbita L. Efficiency boosting for PV systems-MPPT intelligent control based. *Energy Efficiency*. Intech Publisher;2015. <http://dx.doi.org/10.5772/59399>.
- [20] Farhat M, Fleh A, Sbita L. Influence of photovoltaic DC bus voltage on the high speed PMSM drive. In: 38th Annual conference of the IEEE industrial electronics society 2012, 2528 October, Montreal, Quebec, Canada.
- [21] Muthuramalingam M, Manoharan PS. A photovoltaic power system using a high step-up converter for DC load applications. *Energy Convers Manage* 2014;86:286-99.
- [22] Zhou Z, Holland PM, Iqbal P. MPPT algorithm test on a photovoltaic emulating system constructed by a DC power supply and an indoor solar panel. *Energy Convers Manage* 2014;85:4609.
- [23] Forno PV, Romero-Cadaval E, Vinnikov D, Roasto I, Martins JF. Power converter interfaces for electrochemical energy storage systems a review. *Energy Convers Manage* 2014;86:45375.
- [24] Shameem A, Fadi MAI, Saad M, Hazlie M. Fuzzy based controller for dynamic Unified Power Flow Controller to enhance power transfer capability. *Energy Convers Manage* 2014;79:65265.
- [25] Rjula AAB, Abin JAC. A novel MPPT method for PV systems with irradiance measurement. *Sol Energy* 2014;109:95104.
- [26] Abderrahim EF, Fouad G, Abdelmoinime M. Reference voltage optimizer for maximum power tracking in single-phase grid-connected photovoltaic systems. *J Control Syst Eng* 2013;12:5766.
- [27] Farhat M, Barambones O, Ramos JA, Durana JMG. Maximum power point tracking controller based on sliding mode approach. In: *Actas de las XXXV Jornadas de Automática, Valencia, 35 de septiembre, 2014*.