

# Analysis on Effectiveness of Solar Pv-Powered Srm Drive For Electric Vehicles

<sup>1</sup> Kuntumalla.Sri Ranganath, <sup>2</sup> P. Sandeep Kumar,

<sup>1</sup> PG Scholar, Dept of EEE, INTELL Engineering College, Affiliated to JNTUA, AP, India

<sup>2</sup> Assistant Professor, Dept of EEE, INTELL Engineering College, Affiliated to JNTUA, AP, India

**Abstract:** In this paper Hybrid Electric vehicle (HEV) technology provides an effective solution for achieving higher fuel economy and better performances with reduced greenhouse gas emissions. In order to extend the EVs' driving miles, the use of photovoltaic (PV) panels on the vehicle helps decrease the reliance on vehicle batteries. Based on phase winding characteristics of SRMs, a tri-port converter is proposed in this paper to control the energy flow between the PV panel battery and SRM. Six operating modes are presented, four of which are developed for driving and two for standstill on-board charging. In the driving modes, the energy decoupling control for maximum power point tracking (MPPT) of the PV panel and speed control of the SRM are realized. In the standstill charging modes, a grid-connected charging topology is developed without a need for external hardware. When the PV panel directly charges the battery, a multi-section charging control strategy is used to optimize energy utilization. Simulation results based on Matlab/Simulink prove the effectiveness of the proposed tri-port converter, which has potential economic implications to improve the market acceptance of EVs.

**Keywords:** Electric vehicles (EVs), photovoltaics (PVs), power flow control, switched reluctance motors (SRMs), tri-port converter

## I. INTRODUCTION

The demand for electricity has been growing exponentially in recent years. In the meanwhile, long-distance, ultra-high-voltage (UHV), and large-centralized traditional power grid suffers from a lot of problems, which spread in the area of security, economy, excitability, reliability, etc. As the consumption of fossil energy increases, the global greenhouse gas emissions increase significantly, which leads to many serious consequences, such as the global sea level rise, more and more El Nino phenomenon's, and severe land desertification etc. Renewable energy resources, such as

wind and solar energies, as well as their advantages, e.g., ease of use, excitability, environmental friendliness, are capturing more and more attentions from governments in many countries. Distributed power generations provide solutions to increase the reliability of the power grid. From kinds of renewable energies, solar energy is one of the best choices because of its availability.

ELECTRIC vehicles (EVs) have taken a significant leap forward by advances in motor drives, power converters, batteries, and energy control systems. However, due to the limitation of current battery technologies, the driving miles are relatively short that restricts the wide application of EVs. In terms of motor drives, high-performance permanent-magnet (PM) machines are widely used while rare earth materials are needed in large quantities, limiting the wide application of EVs. In order to overcome these issues, a photovoltaic (PV) panel and a switched reluctance motor (SRM) are introduced to provide power supply and motor drive, respectively. First, by adding the PV panel on top of the EV, a sustainable energy source is achieved. Nowadays, a typical passenger car has a surface enough to install a 250-W PV panel. Second, a SRM needs no rare-earth PMs and is also robust so that it receives increasing attention in EV applications. While PV panels have low-power density for traction drives, they can be used to charge batteries most of time.

Electric machines can be broadly classified into two categories on the basis of how they produce torque electromagnetically or by variable reluctance.

In the first category, motion is produced by the interaction of two magnetic fields, one generated by the stator and the other by the rotor. Two magnetic fields, mutually coupled, produce an electromagnetic torque tending to bring the fields into alignment. The same phenomenon causes opposite poles of bar magnets to attract and like poles to repel. The vast majority of motors in commercial use today operate on this principle. These motors, which include DC and

induction motors, are differentiated based on their geometries and how the magnetic fields are generated. Some of the familiar ways of generating these fields are through energized windings, with permanent magnets, and through induced electrical currents.

In the second category, motion is produced as a result of the variable reluctance in the air gap between the rotor and the stator. When a stator winding is energized, producing a single magnetic field, reluctance torque is produced by the tendency of the rotor to move to its minimum reluctance position. This phenomenon is analogous to the force that attracts iron or steel to permanent magnets. In those cases, reluctance is minimized when the magnet and metal come into physical contact. As far as motors that operate on this principle, the switched reluctance motor (SRM) falls into this class of machines.

## II. LITERATURE SURVEY

### 1) Power electronics and motor drives in electric, hybrid electric, and plug-in hybrid electric vehicles.

**A. Emadi, L. Young-Joo, and K. Rajashekara**

With the growing call for environmentally friendlier and better fuel economy cars, automotive corporations are that specialize in electric automobiles, hybrid electric powered motors (HEVs), plug-in hybrid electric automobiles (PHEVs), and fuel-mobile automobiles. These cars could also enable meeting the demands for electrical electricity due to the growing use of the digital capabilities to enhance vehicle overall performance, gasoline economic system, emissions, passenger consolation, and protection. In electric motors, HEVs, PHEVs, and gas-cellular automobiles, the demanding situations are to acquire excessive efficiency, ruggedness, small sizes, and low prices in electricity converters and electric powered machines, in addition to in associated electronics. In unique, in fuel-cellular vehicles, a energy-conditioning unit which includes a dc-dc converter for matching the gas-mobile voltage with the battery % will also be vital. In steer-through-wire and brake-by means of-cord applications, a fast-reaction motor, inverter, and control gadget are important and need to be capable of function in unfavorable environmental situations. Furthermore, the integration of actuators with power electronics now not best improves the general machine reliability however also reduces the cost, length, and so forth. In addition to power electronics, the era of the electrical motor plays a prime function inside the vehicle's dynamics and the form of power converter for controlling the vehicle running traits.

### 2) J. De Santiago et al., "Electrical motor drivelines in commercial allelectric vehicles: A review," *IEEE Trans. Veh. Technol.*, vol. 61, no. 2, pp. 475–484, Feb. 2011.

This paper affords a essential evaluation of the drivelines in all-electric powered automobiles (EVs). The motor topologies which might be the first-rate applicants for use in EVs are offered. The benefits and downsides of each electric motor kind are mentioned from a device perspective. A survey of the electrical cars utilized in business EVs is offered. The survey shows that car manufacturers are very conservative when it comes to introducing new technology. Most of the EVs in the marketplace mount a unmarried induction or everlasting-magnet (PM) motor with a traditional mechanic driveline with a differential. This paper illustrates that comparisons between the unique motors are difficult with the aid of the big wide variety of parameters and the lack of a recommended check scheme. The authors suggest that a standardized pressure cycle be used to test and evaluate cars.

### 3) Z. Amjadi and S. S. Williamson, "Power-electronics-based solutions for plug-in hybrid electric vehicle energy storage and controlment systems," *IEEE Trans. Ind. Electron.*, vol. 57, no. 2, pp. 608–616, Feb. 2010.

Batteries, ultra capacitors (UCs), and gasoline cells are extensively being proposed for electric cars (EVs) and plug-in hybrid EVs (PHEVs) as an electric energy source or an power garage unit. In fashionable, the design of an smart control approach for coordinated power distribution is a essential issue for UC-supported PHEV power structures. Implementation of numerous manipulate techniques has been presented inside the beyond, with the purpose of improving battery existence and common car performance. It is obvious that the control targets range with recognize to automobile speed, electricity call for, and state of fee of both the batteries and UCs. Hence, an top of the line manipulate strategy layout is the maximum critical factor of an all-electric powered/plug-in hybrid electric automobile operational characteristic. Although tons effort has been made to improve the life of PHEV power garage systems (ESSs), including studies on power storage tool chemistries, this paper, at the opposite, highlights the truth that the essential problem lies inside the design of electricity-electronics-based electricity-control converters and the improvement of smarter control algorithms. This paper to begin with discusses battery and UC characteristics and then is going directly to provide a detailed contrast of various proposed

manipulate techniques and proposes the use of specific power electronic converter topologies. Finally, this paper summarizes the benefits of the numerous strategies and indicates the most viable answers for on-board power control, more unique to PHEVs with more than one/hybrid ESSs.

### III. Existing method:

The existing method describes that the electric vehicles have taken a significant leap forward, by advances in motor drives, power converters, batteries and energy management systems. However, due to the limitation of current battery technologies, the driving miles is relatively short that restricts the wide application of EVs. In terms of motor drives, high-performance permanent-magnet (PM) machines are widely used while rare-earth materials are needed in large quantities, limiting the wide application of EVs.

#### Drawbacks of existing method:

- The primary disadvantage of solar power is that it obviously cannot be created during the night.
- The power generated is also reduced during times of cloud cover (although energy is still produced on a cloudy day).
- Solar panel energy output is maximized when the panel is directly facing the sun.

### IV. Proposed method:

In order to overcome these issues, a photovoltaic panel and a switched reluctance motor (SRM) are introduced to provide power supply and motor drive, respectively. Firstly, by adding the PV panel on top of the EV, a sustainable energy source is achieved. Second, a SRM needs no rare-earth PMs and is also robust so that it receives increasing attention in EV applications. While PV panels have low power density for traction drives, they can be used to charge batteries most of time. Generally, the PV-fed EV has a similar structure to the hybrid electrical vehicle, whose internal combustion engine (ICE) is replaced by the PV panel. The PV-fed EV system is illustrated in Fig. 1. Its key components include an off-board charging station, a PV, batteries and power converters. In order to decrease the energy conversion processes, one approach is to redesign the motor to include some on-board charging functions.

#### Advantages of proposed method:

- Solar energy i.e. energy from the sun provide consistent and steady source of solar power throughout the year.
- The main benefit of solar energy is that it can be easily positioned by both home and business users as it does not require any huge set up like in case of wind or geothermal power

### Block diagram of proposed method:

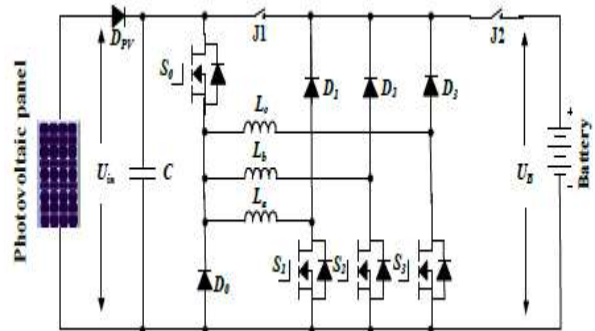
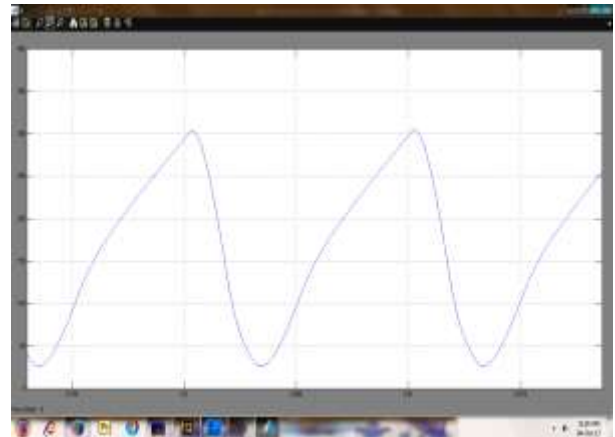

Fig. The proposed Tri-port topology for PV-powered SRM drive.

## V. SIMULATION RESULTS

### Simulation results of driving-charging mode (mode 1)

#### Ic



#### Ib

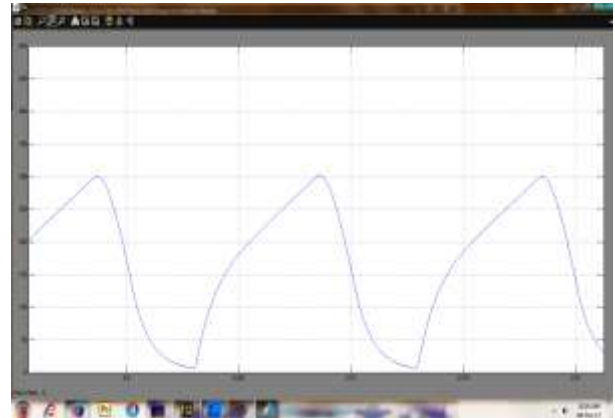

**Ia**

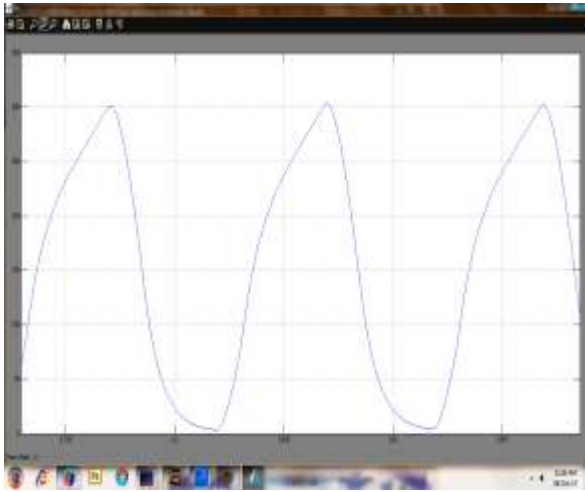

**b) Simulation results of single-source driving mode (modes 3 and 4)**

**Torque(Nm) MODE 3**

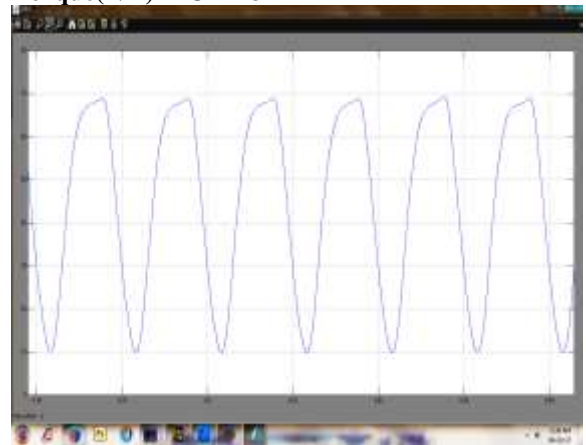

**Iby**



**Torque(Nm) MODE 3**

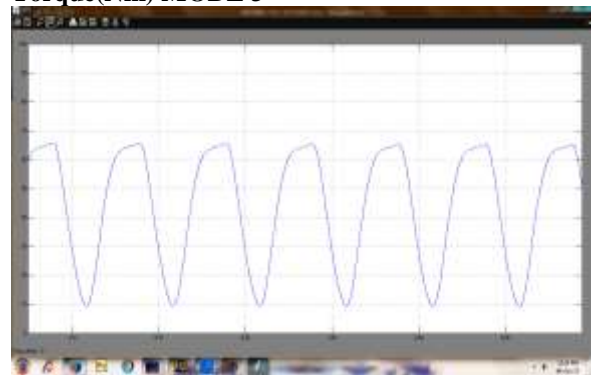

**MODE 3  
Speed(rpm)**

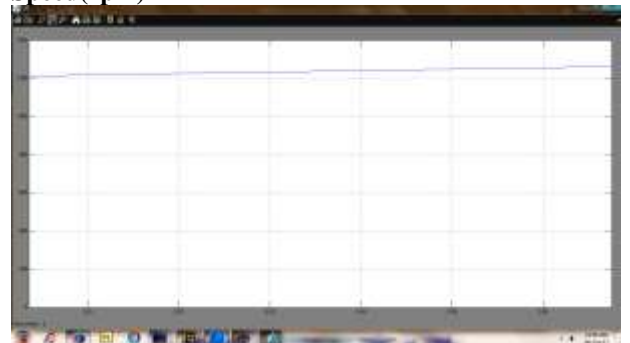

**Uin**

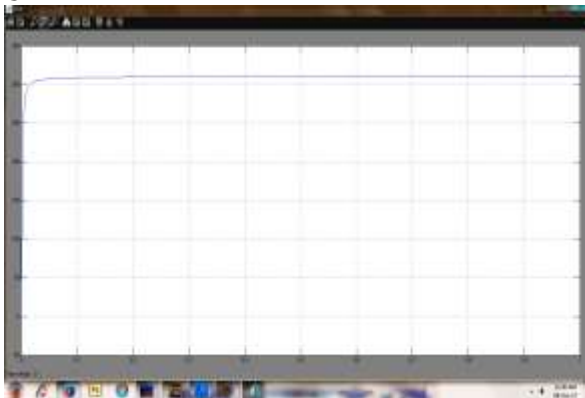

**MODE 4**  
**Speed(rpm)**

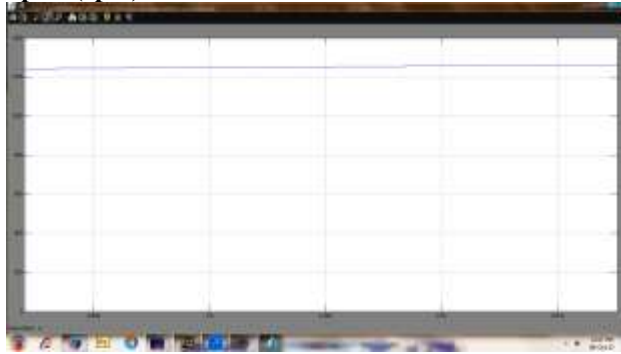

**I<sub>La</sub>**



**I<sub>Lb</sub>**



**I<sub>Lc</sub>**



**II. Simulation results for charging modes. (a) Grid charging (mode 5).**

**U GRID**

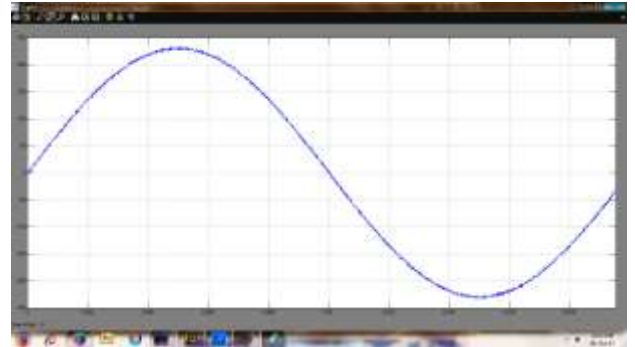

**I GRID**



**PWM S1**



**PWM S2**



**PV charging MODE 6  
STAGE 1**

**$U_B$**

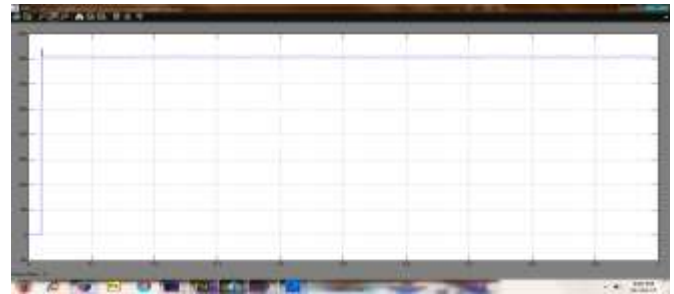
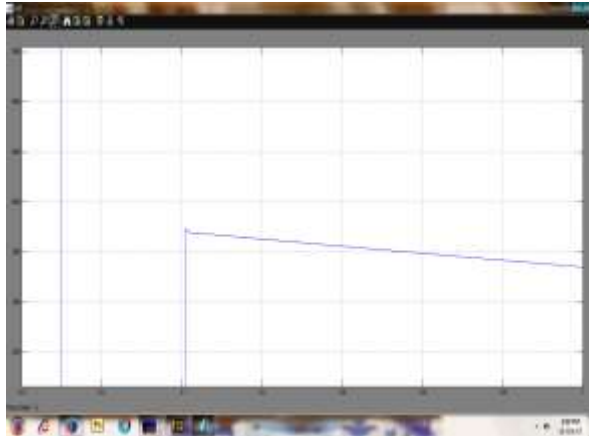

**$U_{in}$**

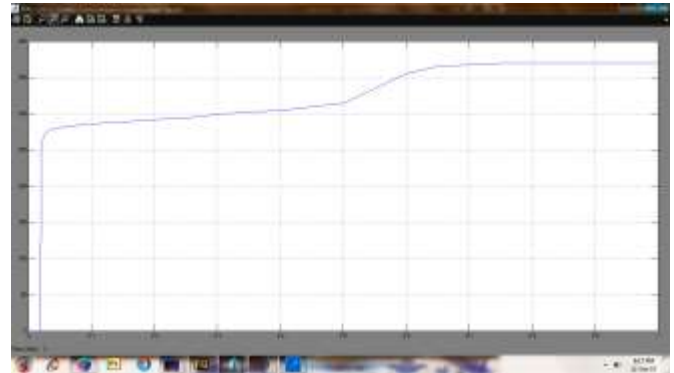

**$U_{in}$**

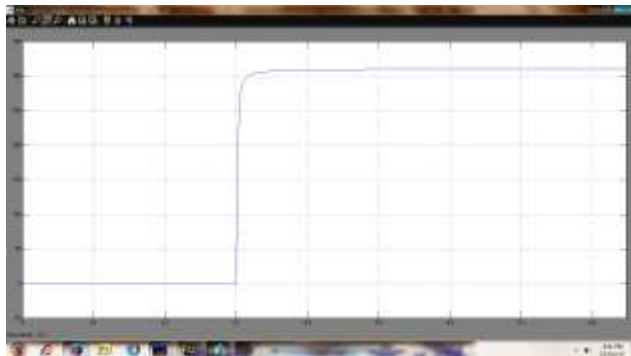

**$I_{La}$**

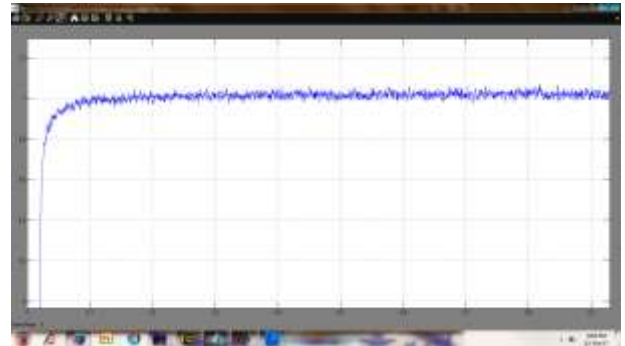

**$I_a$**

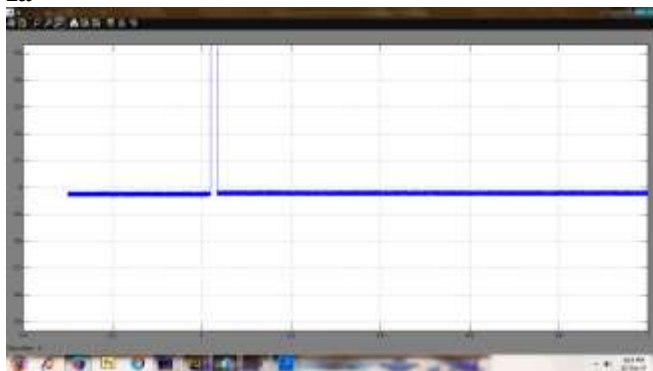

**MODE 6 - STAGE 3**

**$U_B$**

**MODE 6 - STAGE 2**

**$U_B$**

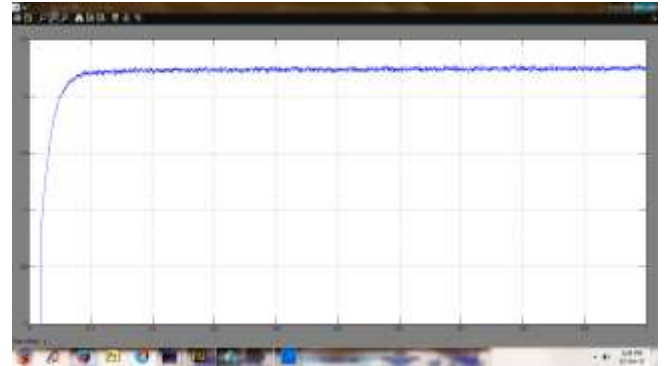
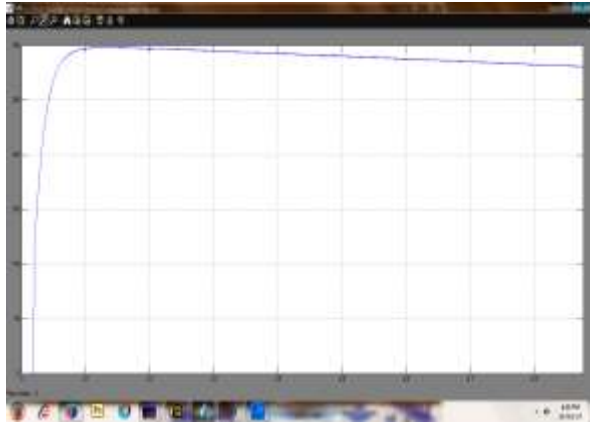

**Uin**

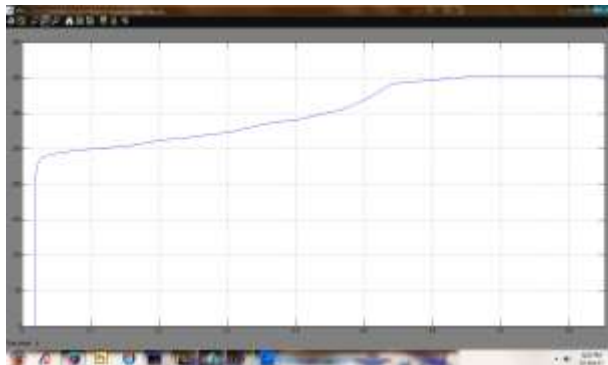

**Ib**

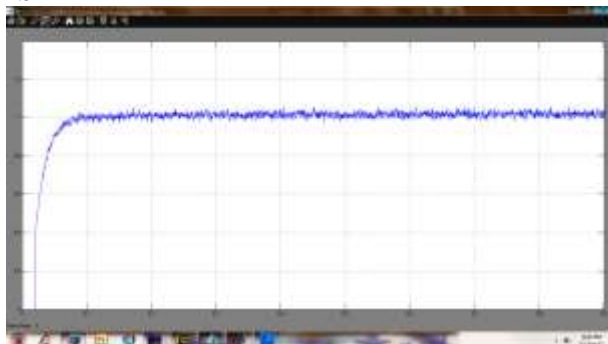

**Ia**

## VII. CONCLUSION

In order to tackle the range anxiety of using EVs and decrease the system cost, a combination of the PV panel and SRM is proposed as the EV driving system. The main contributions of this paper are as follows. 1) A tri-port converter is used to coordinate the PV panel, battery, and SRM. 2) Six working modes are developed to achieve flexible energy flow for driving control, driving/charging hybrid control, and charging control. 3) A novel grid-charging topology is formed without a need for external power electronics devices. 4) A PV-fed

battery charging control scheme is developed to improve the solar energy utilization. Since PV-fed EVs are a greener and more sustainable technology than conventional ICE vehicles, this work will provide a feasible solution to reduce the total costs and CO<sub>2</sub> emissions of electrified vehicles. Furthermore, the proposed technology may also be applied to similar applications such as fuel cell powered EVs. Fuel cells have a much high-power density and are thus better suited for EV application.

## REFERENCES

- [1] A. Emadi, L. Young-Joo, and K. Rajashekara, "Power electronics and motor drives in electric, hybrid electric, and plug-in hybrid electric vehicles," *IEEE Trans. Ind. Electron.*, vol. 55, no. 6, pp. 2237–2245, Jun. 2008.
- [2] L. K. Bose, "Global energy scenario and impact of power electronics in 21st century," *IEEE Trans. Ind. Electron.*, vol. 60, no. 7, pp. 2638–2651, Jul. 2013.
- [3] J. De Santiago et al., "Electrical motor drivelines in commercial allelectric vehicles: A review," *IEEE Trans. Veh. Technol.*, vol. 61, no. 2, pp. 475–484, Feb. 2012.
- [4] Z. Amjadi and S. S. Williamson, "Power-electronics-based solutions for plug-in hybrid electric vehicle energy storage and management systems," *IEEE Trans. Ind. Electron.*, vol. 57, no. 2, pp. 608–616, Feb. 2010.

- [5] A. Kuperman, U. Levy, J. Goren, A. Zafransky, and A. Savernin, "Battery charger for electric vehicle traction battery switch station," *IEEE Trans. Ind. Electron.*, vol. 60, no. 12, pp. 5391–5399, Dec. 2013.
- [6] S. G. Li, S. M. Sharkh, F. C. Walsh, and C. N. Zhang, "Energy and battery management of a plug-in series hybrid electric vehicle using fuzzy logic," *IEEE Trans. Veh. Technol.*, vol. 60, no. 8, pp. 3571–3585, Oct. 2011.
- [7] H. Kim, M. Y. Kim, and G. W. Moon, "A modularized charge equalizer using a battery monitoring IC for series-connected Li-ion battery strings in electric vehicles," *IEEE Trans. Power Electron.*, vol. 28, no. 8, pp. 3779–3787, May 2013.
- [8] Z. Ping, Z. Jing, L. Ranran, T. Chengde, and W. Qian, "Magnetic characteristics investigation of an axial–axial flux compound-structure PMSM used for HEVs," *IEEE Trans. Magn.*, vol. 46, no. 6, pp. 2191–2194, Jun. 2010.
- [9] A. Kolli, O. Béthoux, A. De Bernardinis, E. Labouré, and G. Coquery, "Space-vector PWM control synthesis for an H- bridge drive in electric vehicles," *IEEE Trans. Veh. Technol.*, vol. 62, no. 6, pp. 2441–2452, Jul. 2013.
- [10] Y. Hu, C. Gan, W. Cao, W. Li, and S. Finney, "Central-tapped node linked modular fault tolerance topology for SRM based EV/HEV applications," *IEEE Trans. Power Electron.*, vol. 31, no. 2, pp. 1541–1554, Feb. 2016.