

Fusion Driver Shield, Awareness and Protection

Nambula Srilatha¹, Chitloboina Anil Babu², Naga Ravi Kiran³

¹M.Tech Student, Dept of ECE, Chalapathi Institute of Technology, Guntur, A.P.

²Assistant Professor, Dept of ECE, Chalapathi Institute of Technology, Guntur, A.P.

³Associate professor & HOD, Dept. of ECE, Chalapathi Institute of Technology, Guntur, A.P.

ABSTRACT:

The primary aim would be to provide awareness and safety mechanism for that driver. Primary reason of the accident is a result of drinking and abnormal pulse rate of driving person. Additionally for this thievery recognition, home security system and person level identification is decided. The primary utilization of human level identification technique is to recognize the individual within the vehicle. Passive infrared sensor can be used this detects a person's level. Within this paper alcohol recognition and heartbeat monitoring system, person level identification system, accident alert, thievery recognition and mobile free auto reply technique is accustomed to avoid any sort of accident. Assume motor as engine. To begin engine user needs to send SMS from mobile. Within this project we're using LPC2148 is primary controller. It is associated with ARM7 architecture. GSM modem is linked to

controller through serial interface. IR sensor, smoke sensor (MQ2), Heart beat sensors are linked to controller through digital I/O lines. Motor also associated with H-bridge or relay. Accidents mainly occur because of driver negligence. Their simulation output is observed by LABVIEW or MATLAB and also the hardware module is acquired. Hardware module for hybrid driver safety product is acquired with three methods namely alcohol recognition, heartbeat monitoring system, person level identification method, eye blink sensor and thievery identification. Password authentication, calls divert method, pulse level mechanism is processed. Both way scan be used to rectify the negligence from the driver and immediate intimation strategy is produced by utilization of GSM technology.

Keywords: *MQ3 sensor, IR sensor, Heart rate monitoringsystem, Passive infrared*

sensor, Password authentication and auto

1. INTRODUCTION:

Alcohol recognition method, Heartbeat monitoring system, Human level identification methods are utilized to minimize the amount of any sort of accident. For Heartbeat heartbeats are usually expressed as bpm. Sensor's really a device that detects changes or occasions in quantities and offers an output a k in to the input the signal usually in optical or electrical signal [1]. Sensors obey certain condition and rules. A person PIR sensor detects alterations in the quantity of infrared radiation. The sensor converts the resulting alternation in the incoming infrared radiation into a general change in the output current, which triggers the recognition. Because of health problem accident can happen, assuming there's a less pulse level then person can lead to unconscious stage. Lack of individual is mainly because of cardiac arrest, drunk driving only so this is often reduced by utilizing different techniques. There's a very efficient automatic system for early recognition of outgoing and incoming call. Discovering the reasons for example drinking, range pulse level, person and sleepiness level

reply SMS GSM.

identification, thievery recognition and home security systems are handled within the hybrid driver safety awareness method [2].

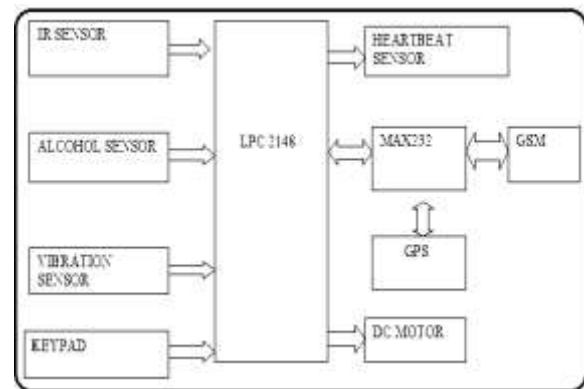

Fig.1. Framework of proposed model

2. IMPLEMENTATION:

To beginning in user needs to send SMS from mobile. Or noab normal conditions like MQ2 enable, high heartbeat or IR activation (Accident) SMS will got mobile number with area longitude, latitude values. This project uses controlled 5V 500mA power. Within this project we're using LPC2148 is primary controller. It is associated with ARM7 architecture. GSM modem is linked to controller through serial interface. IR sensor, smoke sensor (MQ2), Heartbeat sensors are linked to controller through digital I/O lines [3]. Motor also associated



with H-bridge or relay. Assume motor as engine. A 7805 three terminal current regulator can be used for current regulation. Bridge type full wave rectifier can be used to rectify the accretion of secondary of 230/12V step lower transformer. In accident avoid an once system: Drunk driver prevention, human level recognition and heartbeat measurement technique is used. These preventive methods mostly are employed for staying away from accident. If you're driving person consumes any alcohol or drug this made the individual to get an unconscious stage for this reason accident occurs. Accidents occur because of lack of health problems or with no understanding of owner that is a result of less oxygen level within the vehicle is reduced then person die. Three methods namely drunk driver prevention, human level [4]. These techniques mostly are accustomed to sense the signal which signals are controlled through the controller .ARM controller LPC 2148 is programmed according to alcohol condition, human level recognition and pulse rate monitoring. Alcohol sensor in structs the motive force to blow air in to the sensor unit and checks the alcohol content contained in them olive

force breath. Heartbeat sensor can be used for calculating the heartbeat rate. If pulse level is high even just in that situation if driver drives the automobile then your system will apply brakes instantly to slow lower and halt the automobile. For eye blink sensor IR sensor can be used to sense the signal. If Eye Blink range is less then automatic intimation is offered. Thievery recognition and home security system can be found within the hybrid model. Alcohol Recognition product is accustomed to appraise the alcohol content contained in the body. If alcohol submissions are high, then there's a decrease in breathing level, for this reason accident can happen. The quantity of alcohol in blood stream is known as blood stream alcohol level. Alcohol level is measured by utilization of the gas discovering sensor. There's an MQ3 gas sensor, which is often used to identify the alcohol level as well as their values are delivered to controller. When the value is greater compared to threshold value the nignition product is not began. Alcohol Recognition Method accustomed to identify the alcohol content, within this MQ3 alcohol sensor unit can be used to determine the breath of the person if the alcohol consumed

or otherwise. Heartbeat sensor method is a straight forward device that gets to be a sample of signal healthy of pulse rate and calculates the center beat signal a sbpm. Normally human heart beat is all about 70bpm for males and 75 beats for women [5]. The primary utilization of human level identification technique is to recognize the individual within the vehicle. Passive infrared sensor can be used this detects a person's level. If vehicle is not being used for the reason that situation window from the vehicle is within closed symptom in such situation or no individual is within the vehicle with any understanding from the owner then your person within the vehicle will for their oxygen level, here the carbon-di-oxide level is elevated for this reason person may die. Recognition methods include two ways. One of the ways is Eye blink sensor method, next is thievery recognition process. The majority of the accident occurs because of sleepiness. This sleepiness level is detected by utilization of eye blink sensor. IR sensor can be used identify the blink of the eye. Within this IR transmitter can be used to deliver the infrared sun rays in eye. The IR receiver can be used to get the reflected infrared sun rays

from the eye. When the eye is closed means the creation of IR receiver is high otherwise the IR receiver output is low [6]. There's an inverting and non inverting input terminal by which in line with the reference signal and input signal the output is acquired. The compared output is share with the ARM controller and when their value is more than the brink value. When the value is high then alarm seem is created. Counting of the eye blink is calculated. The automobile anti thievery system includes different layers for example password recognition and also the matching process .Thievery occurs according to that the door ways are opened up. When the vehicle is switched ON then using the mechanical keys together with correct key number door is opened up. Vehicles thievery is recognized by utilization of the password method. The password is offered towards the ARM controller in the keypad switch the password is offered. When the password is matched then your intimation is send towards the owner therefore, the vehicle is began. If password isn't matched then vehicle isn't began then intimation is send towards the owner [7].

3. CONCLUSION:

Bridge type full wave rectifier can be used to rectify the accretion of secondary of 230/12V step lower transformer. Mobile hands held system and face recognition techniques can be used as future application. This project uses controlled 5V 500mA power. A 7805 three terminal current regulator can be used for current regulation. The primary utilization of human level identification technique is to recognize the individual within the vehicle. Passive infrared sensor can be used this detects a person's level. Hardware module for hybrid driver safety product is acquired with three methods namely alcohol recognition, heartbeat monitoring system, person level identification method, eye blink sensor and thievery identification. The presented jobs are accustomed to steer clear of the accident by utilization of heart beat monitoring system, alcohol recognition and person level identification method additionally for this three method there's recognition method for example eye blink sensor, thievery recognition, home security system can be used. LABVIEW simulation is acquired by providing different input towards the process. Hardware module and LABVIEW simulation for driver authentication and

accident avoidance system ended and output was acquired.

REFERENCES:

- [1] Elvi R, Christensen and Amundsen, 2004, 'Speed and road accidents An evaluation of the Power Model', Institute of Transport Economics, Oslo.
- [2] M. Chehreghani Bozchalui, "Optimal operation of energy hubs in the context of smart grids," Ph.D. dissertation, Dept. Elect. Comput. Eng., Univ. Waterloo, Waterloo, ON, Canada, 2011.
- [3] M. Chehreghani Bozchalui, S. Hashmi, H. Hassen, C. Canizares, and K. Bhattacharya, "Optimal operation of residential energy hubs in smart grids," IEEE Trans. Smart Grid, vol. 3, no. 4, pp. 1755–1766, Dec. 2012.
- [4] Chin Teng Lin, 2014 'Wireless and Wearable EEG System for Evaluating Driver Vigilance', IEEE Transactions on biomedical circuits and systems, Vol.15, No.8, pp.230-255.

[5] Chi Zhang, Hong Wang and Rongrong Fu, 'Automated Detection of Driver Fatigue Based on Entropy and Complexity Measures', IEEE Transaction on intelligent transportation systems.

[6] AartsL.andSchagen, (2005)Driving Speed and the risk of roadcrashes', AccidentAnalysis and Prevention.



**NAMBULA
SRILATHA, M.Tech Student.**

**CHITLOBOINA ANIL BABU
Assistant Professor**